

Code	Description	Notes
A.01.01_0_45556	ENGINE	Engine: 75 CV
A.01.01_1_48842	ENGINE	Engine: 75 CV
A.01.02_0_48885	ENGINE	Engine: 85 CV
A.01.02_1_45599	ENGINE	Engine: 85 CV
A.01.03_0_48930	ENGINE	Engine: 95 CV
A.01.03_1_45644	ENGINE	Engine: 95 CV
A.02.02_0_42523	ENGINE CONTROLS	
A.03.01_0_45689	COOLER	Engine: 75 CV
A.03.02_0_45727	COOLER	Engine: 85 CV, 95 CV
A.04.01_0_45765	AIR FILTER	Engine: 75 CV
A.04.02_0_45780	AIR FILTER WITH EXTERNAL AIR INTAKE	Engine: 75 CV
A.04.03_0_45796	AIR FILTER	Engine: 85 CV, 95 CV
A.04.04_0_45812	AIR FILTER WITH EXTERNAL AIR INTAKE	Engine: 85 CV, 95 CV
A.05.02_0_45864	FUEL TANK	
B.01.01_0_47067	FRONT SUPPORT	
B.02.01_0_47127	BONNET	
B.02.01_1_47161	BONNET	
B.03.03_0_50588	FRONT MUDGUARDS	
B.03.04_0_50621	FRONT MUDGUARDS (VERSION WITH CAB)	
B.04.07_0_40076	BOARDS	
B.05.03_0_50689	REAR MUDGUARDS	
B.05.04_0_50716	REAR MUDGUARDS (VERSION WITH CAB)	
B.07.02_0_42592	PLATES AND STICKERS	
B.08.02_0_38771	DASHBOARD	
B.11.01_0_38871	SEAT SUPPORT / GEAR LEVERS COVER	
B.12.03_0_46827	SEAT (STANDARD)	
B.12.04_0_51054	SEAT (KAB)	
C.01.02_0_39031	FRONT AXLE	
C.02.04_0_39172	CENTRAL SECTION	
C.02.04_1_39212	CENTRAL SECTION	
C.03.02_0_39268	REAR AXLE	
D.01.02_0_40152	FRONT TRANSMISSION	
D.02.02_0_39318	CLUTCH FRONT SHAFT/ TRANSMISSION CLUTCH	
D.03.02_0_39758	CLUTCH CONTROLS	

Thor 75-85-95 AR Reversible

Code	Description	Notes
D.03.02_1_39804	CLUTCH CONTROLS	
D.04.01_0_42820	INPUT SHAFT / RANGES MAIN SHAFT / GEARS	Version: RS-M, RS-R, AR-M, AR-R
D.04.01_1_42845	INPUT SHAFT / RANGES MAIN SHAFT / GEARS	Version: RS-M, RS-R, AR-M, AR-R
D.05.01_0_42870	GEARS MAIN SHAFT / GEARS	Version: RS-M, RS-R, AR-M, AR-R
D.05.01_1_42883	GEARS MAIN SHAFT / GEARS	Version: RS-M, RS-R, AR-M, AR-R
D.06.01_0_42896	GEARS TRANSMISSION SHAFT / GEARS	Version: RS-M, RS-R, AR-M, AR-R
D.06.01_1_42932	GEARS TRANSMISSION SHAFT / GEARS	Version: RS-M, RS-R, AR-M, AR-R
D.07.02_0_39660	GEARBOX CONTROLS	
D.07.02_1_39700	GEARBOX CONTROLS	
D.08.01_0_42969	MECHANICAL LOCK	Version: RS-M, RS-R, AR-M, AR-R
D.09.02_0_39867	REAR TRANSMISSION	
D.10.01_0_39887	EPYCLIC REDUCTION GEARS	
D.11.01_0_40184	DIFFERENTIAL LOCK	
D.12.01_0_40202	POWER TAKE-OFF	
D.12.01_1_40279	POWER TAKE-OFF	
D.13.01_0_40355	POWER TAKE-OFF CONTROLS	
D.14.01_0_40378	BRAKES	
D.15.04_0_40488	BRAKES CONTROLS	
E.01.01_0_42630	FRONT ELECTRICAL SYSTEM	
E.02.01_0_46767	ENGINE ELECTRIC SYSTEM	
E.03.02_0_42668	REAR ELECTRICAL SYSTEM	
F.01.03_0_51164	HYDR. SYSTEM DOUBLE OIL SUCTION	
F.02.01_0_51232	HYDR. SYSTEM : HEAT EXCHANGER	
F.03.04_0_40779	STEERING HYDR. SYSTEM	
F.03.04_1_40827	STEERING HYDR. SYSTEM	
F.04.01_0_46735	PTO /DIFFERENTIAL LOCK HYDR. SYSTEM	
I.01.01_0_40883	HYDR. CONTROL VALVES: AVAILABLE PARTS	
L.01.01_0_40903	RAISE/LOWER LIFT	
L.02.02_0_40987	FREE DISCHARGE CONTROL VALVES VERSION	
L.02.05_0_41145	CONTROL VALVES WITHOUT FREE DISCHARGE VERSION	
M.01.01_0_41199	POSITION AND DRAFT CONTROL LIFT	
M.02.03_0_41409	FREE DISCHARGE CONTROL VALVES VERSION	
M.02.04_0_41480	CONTROL VALVES WITHOUT FREE DISCHARGE VERSION	
T.02.01_0_41647	IMPLEMENTS ATTACHMENT - STANDARD	

Thor 75-85-95 AR Reversible

Code	Description	Notes
T.02.02_0_41675	IMPLEMENTS ATTACHMENT - ADJUSTABLE ARMS WITH QUICK HITCHES	
T.03.01_0_41710	PULL HOOK - STANDARD	
T.03.02_0_41719	POOL HOOK "EEC" APPROVED	
T.03.03_0_42459	SLIDER FRAME WITH POOL HOOK "EEC" APPROVED	
W.01.03_0_44163	WHEELS AND TYRES (TABLE 1/2)	
W.01.04_0_45316	WHEELS AND TYRES (TABLE 2/2)	

VM MOTORI

MOTORE 4 CILINDRI - "13 C"
 4 CYLINDERS ENGINE - "13 C"
 MOTEUR 4 CYLINDRES - "13 C"
 4 ZYLINDER MOTOR - "13 C"
 MOTOR 4 CILINDROS - "13 C"

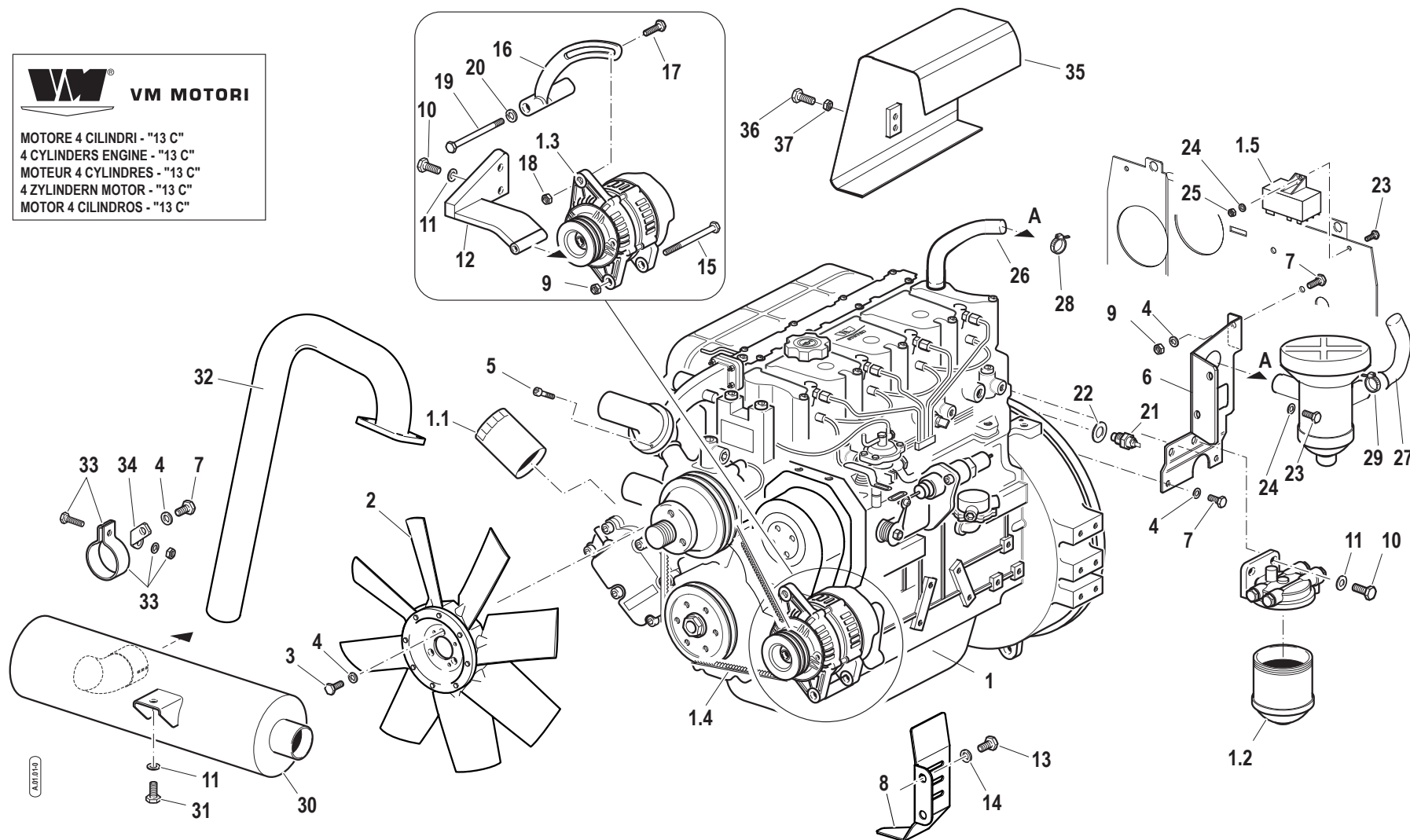

Pos.	Code	Q.ty	Description	Notes
1	41U50000	1	MOT.VM D754E2.21A 47KW 13C/4	
1.1	58171199	1	FILTER INSERT	
1.2	58171200	1	FILTER INSERT	
1.3	59900344	1	ALTERNATOR	
1.4	59900766	1	BELT	
1.5	59900345	1	CENTRAL PROCESSING UNIT	
10	31112219	5	SCREW TE M10X25 UNI 5739	
11	F0843755000	6	WASHER 10	
12	59077318	1	SUPPORT	
13	31112082	2	SCREW TE M6X12 UNI 5739 8G	
14	31411064	2	WASHER 6,4x12,5	
15	31112174	1	SCREW TE M8X110 UNI 5737 8.8	
16	59076688	1	ROD	
17	31112153	1	SCREW TE M8X35 UNI 5739 8G	
18	31421083	1	WASHER	
19	F0864335020	1	SCREW M14X120 UNI 5737	
2	57376726	1	FAN	
20	31421251	1	WASHER	
21	58175773	1	ELECTRONICAL THERMOMETER	
22	F0844030070	1	COPPER WASHER 16,0x22/1,5	
23	31112090	2	SCREW TE M6X16 UNI 5739 8G	
24	F0843570000	2	WASHER 6	
25	31211060	2	NUT M6	
26	55176744	1	PIPE	
27	58177400	1	OIL PIPE	
28	F0817500400	3	CLAMP 024,1-706R	
29	F0817500200	1	CLAMP 015,7-706R	
3	31112150	3	SCREW TE M8X20 UNI 5739 8G	
30	58176618	1	EXHAUST SILENCER	
31	31112210	1	SCREW TE M10X20 UNI 5739	
32	59076620	1	EXHAUST	
33	58175121	1	COLLAR	
34	56177183	1	REINFORCED STRAP	
35	59077480	1	GUARD	

SERIAL

ENGINE
Engine: 75 CV

CODE REV

A.01.01_0_45556

VM MOTORI

MOTORE 4 CILINDRI - "13 C"
 4 CYLINDERS ENGINE - "13 C"
 MOTEUR 4 CYLINDRES - "13 C"
 4 ZYLINDER MOTOR - "13 C"
 MOTOR 4 CILINDROS - "13 C"

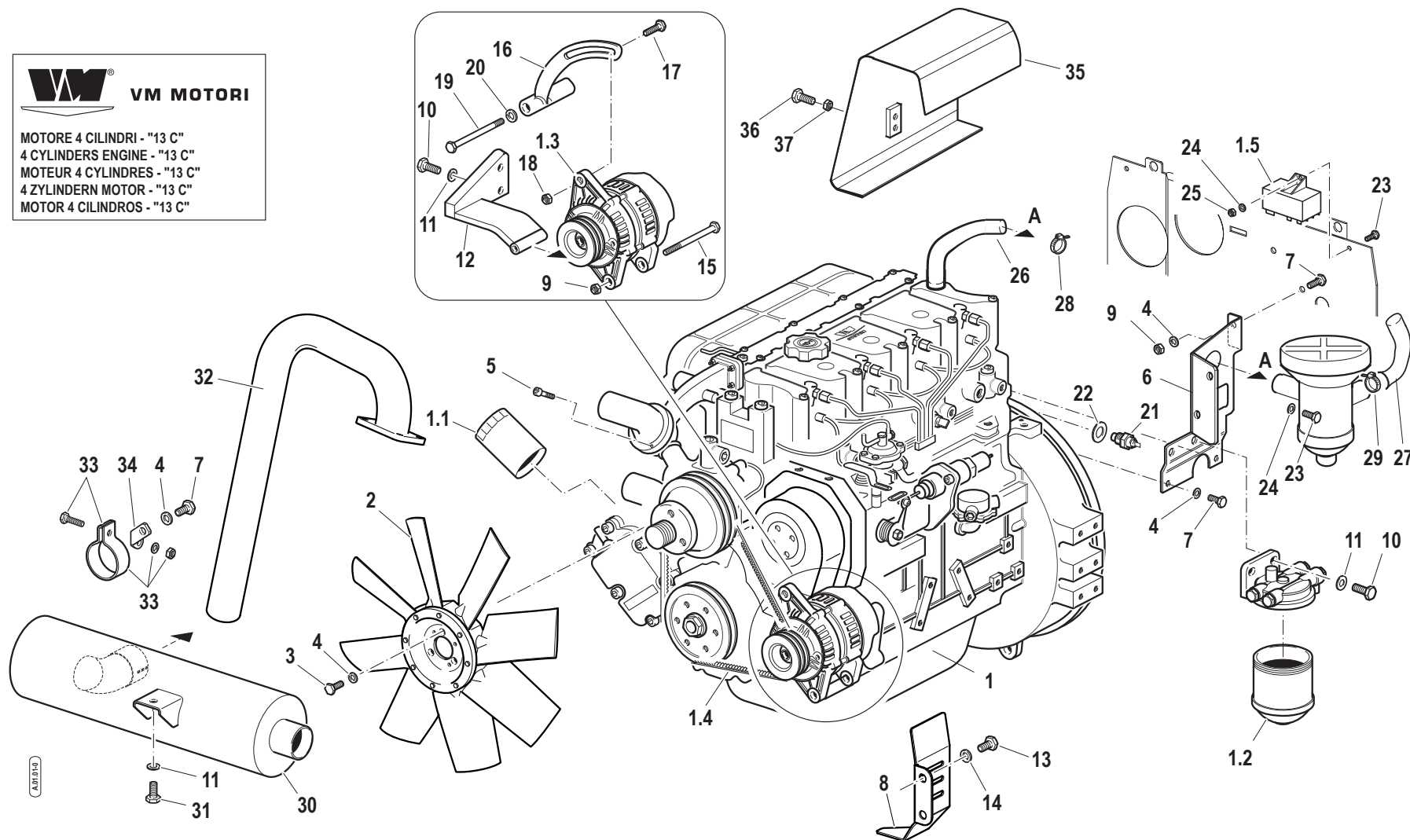

Pos.	Code	Q.ty	Description	Notes
36	F0838384000	1	STUD BOLT M10X25 UNI 5911 8.8	
37	31215100	1	NUT M10	
4	F0843643060	7	WASHER 8	
5	F0862479035	1	SCREW M6X16 7380	
6	59079167	1	RETAINER	
7	31111151	4	SCREW TE M8X16 UNI 5739 8G	
8	56177979	1	SHIELD	
9	31211080	2	NUT M8	

SERIAL

ENGINE
Engine: 75 CV

CODE REV

A.01.01_0_45556

VM MOTORI

MOTORE 4 CILINDRI - "13 C"
 4 CYLINDERS ENGINE - "13 C"
 MOTEUR 4 CYLINDRES - "13 C"
 4 ZYLINDER MOTOR - "13 C"
 MOTOR 4 CILINDROS - "13 C"

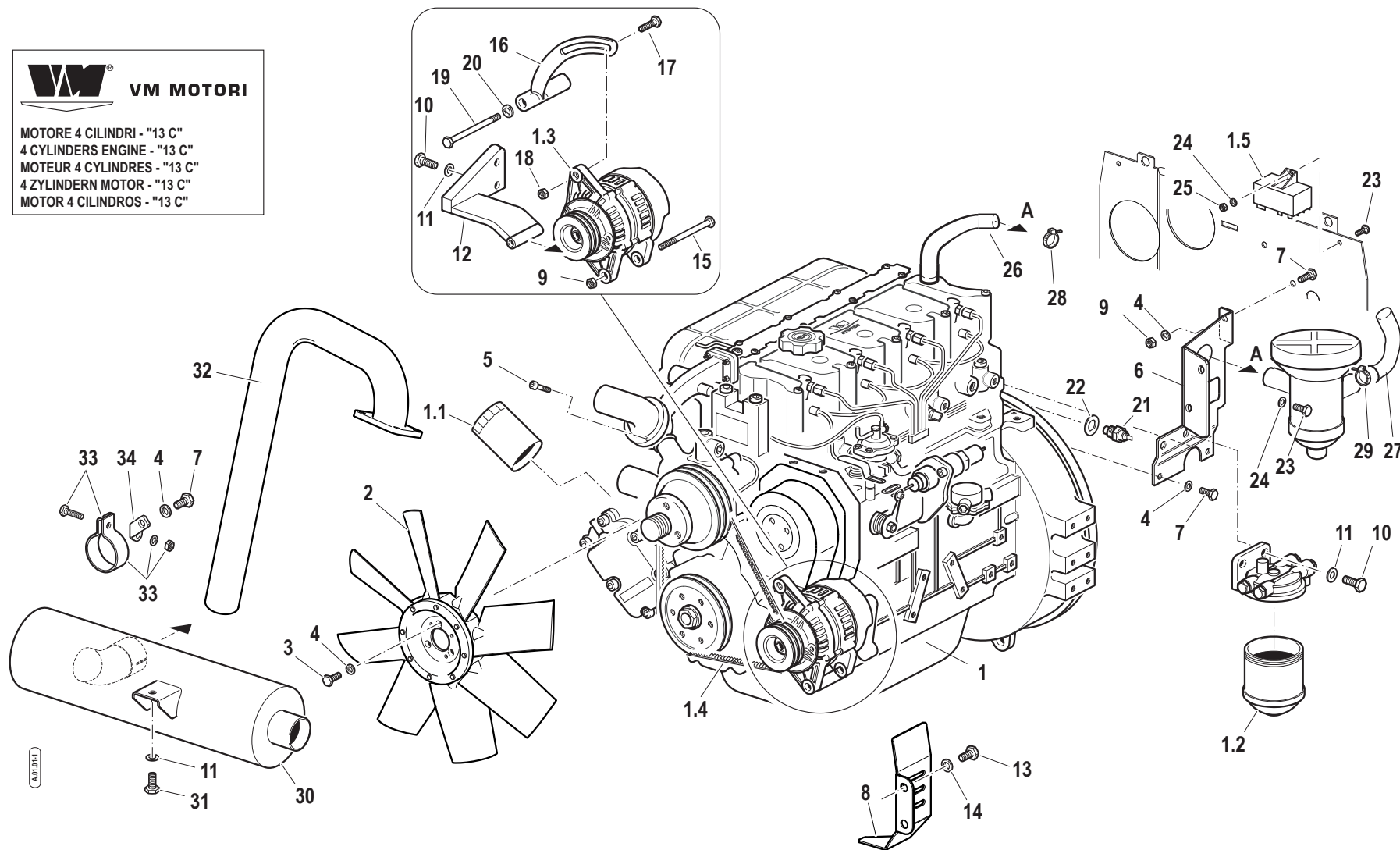

Pos.	Code	Q.ty	Description	Notes
1	41U50000	1	MOT.VM D754E2.21A 47KW 13C/4	
1.1	58171199	1	FILTER INSERT	
1.2	58171200	1	FILTER INSERT	
1.3	59900344	1	ALTERNATOR	
1.4	59900766	1	BELT	
1.5	59900345	1	CENTRAL PROCESSING UNIT	
10	31112219	5	SCREW TE M10X25 UNI 5739	
11	F0843755000	6	WASHER 10	
12	59077318	1	SUPPORT	
13	31112082	2	SCREW TE M6X12 UNI 5739 8G	
14	31411064	2	WASHER 6,4x12,5	
15	31112174	1	SCREW TE M8X110 UNI 5737 8.8	
16	59076688	1	ROD	
17	31112153	1	SCREW TE M8X35 UNI 5739 8G	
18	31421083	1	WASHER	
19	F0864335020	1	SCREW M14X120 UNI 5737	
2	57376726	1	FAN	
20	31421251	1	WASHER	
21	58175773	1	ELECTRONICAL THERMOMETER	
22	F0844030070	1	COPPER WASHER 16,0x22/1,5	
23	31112090	2	SCREW TE M6X16 UNI 5739 8G	
24	F0843570000	2	WASHER 6	
25	31211060	2	NUT M6	
26	55176744	1	PIPE	
27	58177400	1	OIL PIPE	
28	F0817500400	3	CLAMP 024,1-706R	
29	F0817500200	1	CLAMP 015,7-706R	
3	31112150	3	SCREW TE M8X20 UNI 5739 8G	
30	58176618	1	EXHAUST SILENCER	
31	31112210	1	SCREW TE M10X20 UNI 5739	
32	59076620	1	EXHAUST	
33	58175121	1	COLLAR	
34	56177183	1	REINFORCED STRAP	
4	F0843643060	7	WASHER 8	

SERIAL

ENGINE
Engine: 75 CV

CODE REV

A.01.01_1_48842

VM MOTORI

MOTORE 4 CILINDRI - "13 C"
 4 CYLINDERS ENGINE - "13 C"
 MOTEUR 4 CYLINDRES - "13 C"
 4 ZYLINDER MOTOR - "13 C"
 MOTOR 4 CILINDROS - "13 C"

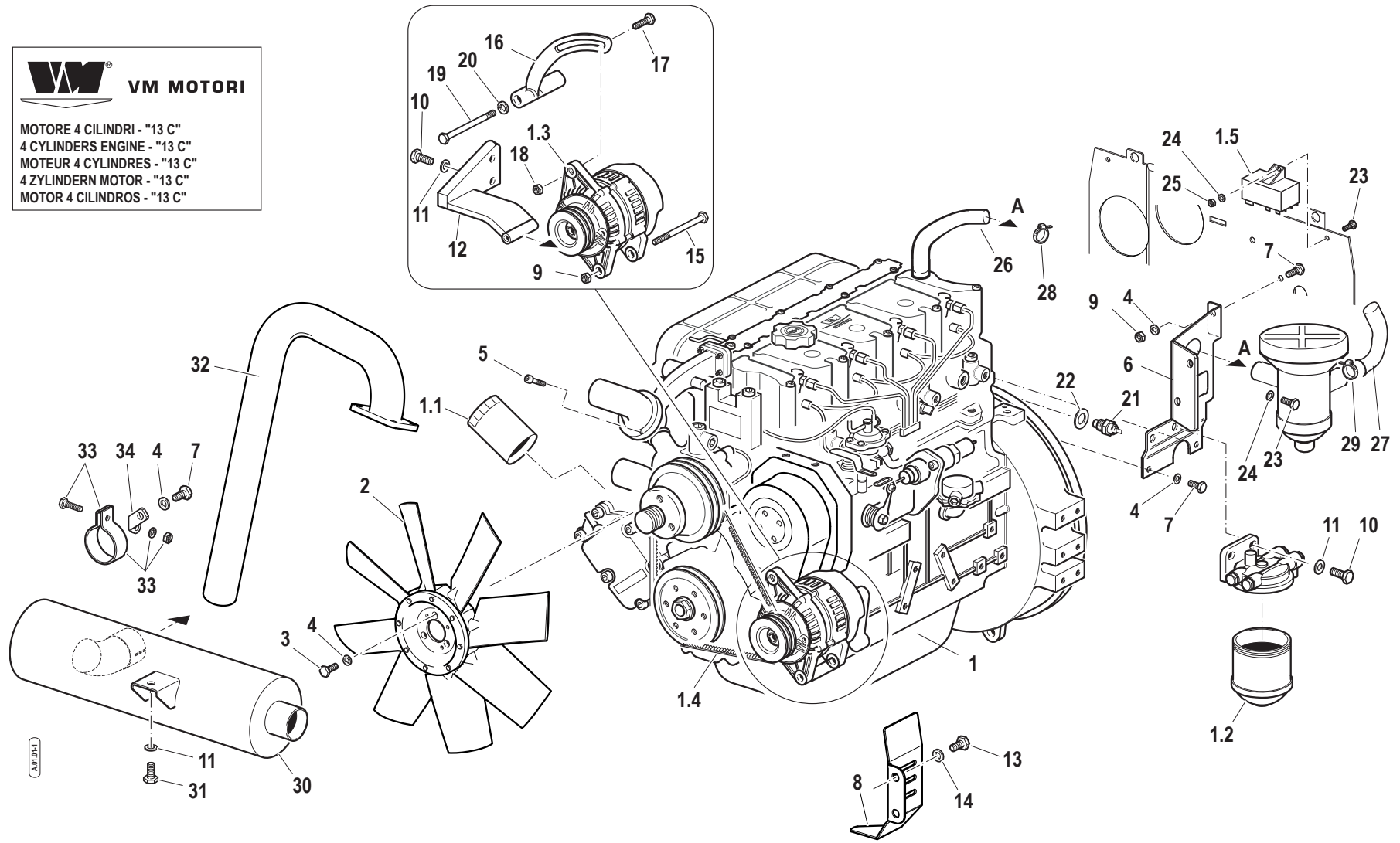

Pos.	Code	Q.ty	Description	Notes
5	F0862479035	1	SCREW M6X16 7380	
6	59079167	1	RETAINER	
7	31111151	4	SCREW TE M8X16 UNI 5739 8G	
8	56177979	1	SHIELD	
9	31211080	2	NUT M8	

VM MOTORI

MOTORE 4 CILINDRI - "77 B"
 4 CYLINDERS ENGINE - "77 B"
 MOTEUR 4 CYLINDRES - "77 B"
 4 ZYLINDER MOTOR - "77 B"
 MOTOR 4 CILINDROS - "77 B"

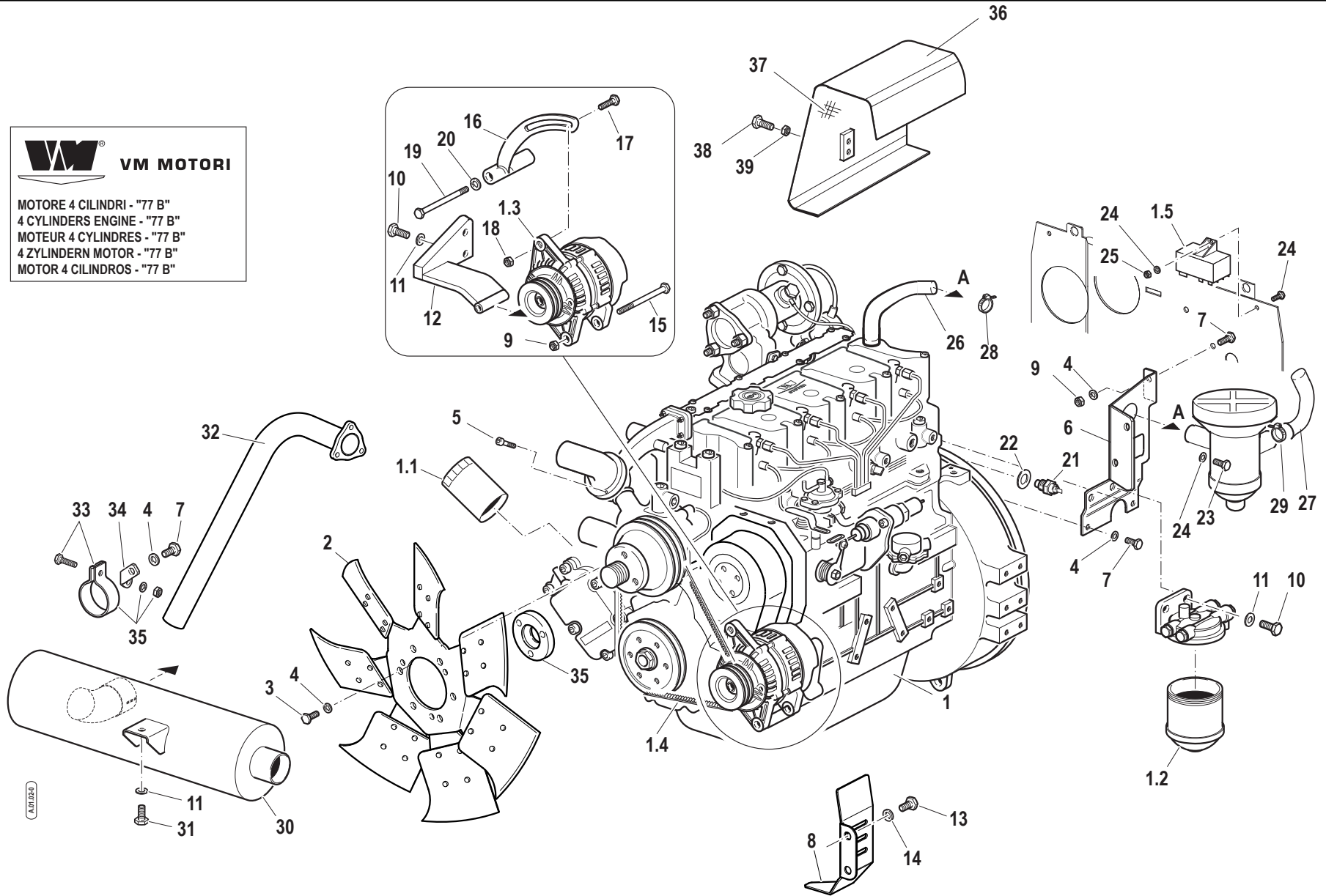

Pos.	Code	Q.ty	Description	Notes
1	41U60000	1	MOT.VM D704TE2.21A 60KW 77B/4	
1.1	58171199	1	FILTER INSERT	
1.2	58171200	1	FILTER INSERT	
1.3	59900344	1	ALTERNATOR	
1.4	59900766	1	BELT	
1.5	59900345	1	CENTRAL PROCESSING UNIT	
10	31112219	5	SCREW TE M10X25 UNI 5739	
11	F0843755000	6	WASHER 10	
12	59077318	1	SUPPORT	
13	31112082	2	SCREW TE M6X12 UNI 5739 8G	
14	31411064	2	WASHER 6,4x12,5	
15	31112174	1	SCREW TE M8X110 UNI 5737 8.8	
16	59076688	1	ROD	
17	31112153	1	SCREW TE M8X35 UNI 5739 8G	
18	31421083	1	WASHER	
19	F0864335020	1	SCREW M14X120 UNI 5737	
2	58178646	1	FAN	
20	31421251	1	WASHER	
21	58175773	1	ELECTRONICAL THERMOMETER	
22	F0844030070	1	COPPER WASHER 16,0x22/1,5	
23	31112090	2	SCREW TE M6X16 UNI 5739 8G	
24	F0843570000	2	WASHER 6	
25	31211060	2	NUT M6	
26	55176744	1	PIPE	
27	58177400	1	OIL PIPE	
28	F0817500400	3	CLAMP 024,1-706R	
29	F0817500200	1	CLAMP 015,7-706R	
3	F0862694000	3	SCREW M8X170 UNI 5737	
30	58176618	1	EXHAUST SILENCER	
31	31112210	1	SCREW TE M10X20 UNI 5739	
32	59076619	1	EXHAUST	
33	58175121	1	COLLAR	
34	56177183	1	REINFORCED STRAP	
35	56178649	1	SPACER	

SERIAL

ENGINE
Engine: 85 CV

CODE REV

A.01.02_0_48885

VM MOTORI

MOTORE 4 CILINDRI - "77 B"
 4 CYLINDERS ENGINE - "77 B"
 MOTEUR 4 CYLINDRES - "77 B"
 4 ZYLINDER MOTOR - "77 B"
 MOTOR 4 CILINDROS - "77 B"

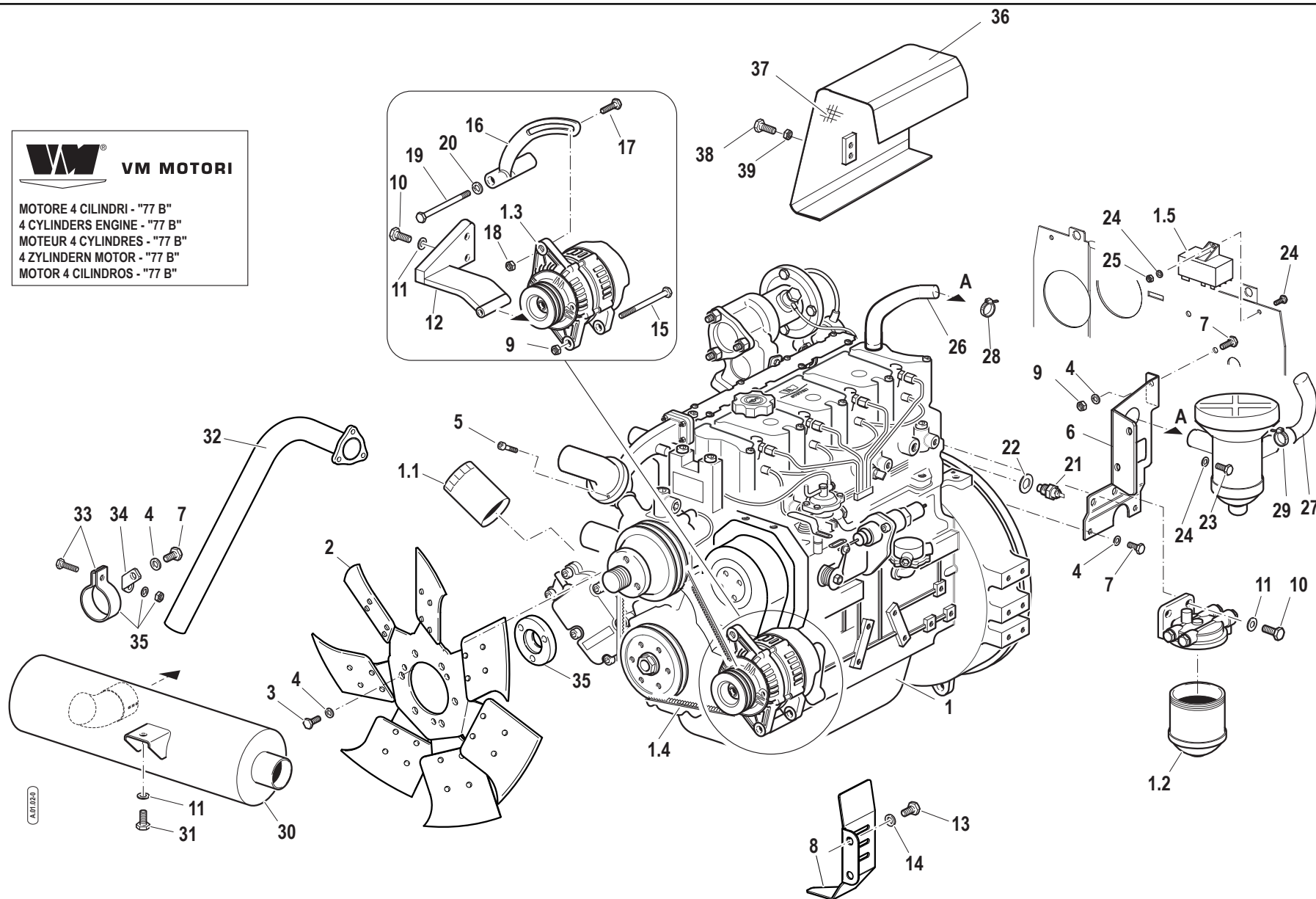

Pos.	Code	Q.ty	Description	Notes
36	59077480	1	GUARD	
37	58077484	1	LINING	
38	F0838384000	1	STUD BOLT M10X25 UNI 5911 8.8	
39	31215100	1	NUT M10	
4	F0843643060	7	WASHER 8	
5	F0862479035	1	SCREW M6X16 7380	
6	59079167	1	RETAINER	
7	31111151	4	SCREW TE M8X16 UNI 5739 8G	
8	56177979	1	SHIELD	
9	31211080	2	NUT M8	

VM MOTORI

MOTORE 4 CILINDRI - "77 B"
 4 CYLINDERS ENGINE - "77 B"
 MOTEUR 4 CYLINDRES - "77 B"
 4 ZYLINDER MOTOR - "77 B"
 MOTOR 4 CILINDROS - "77 B"

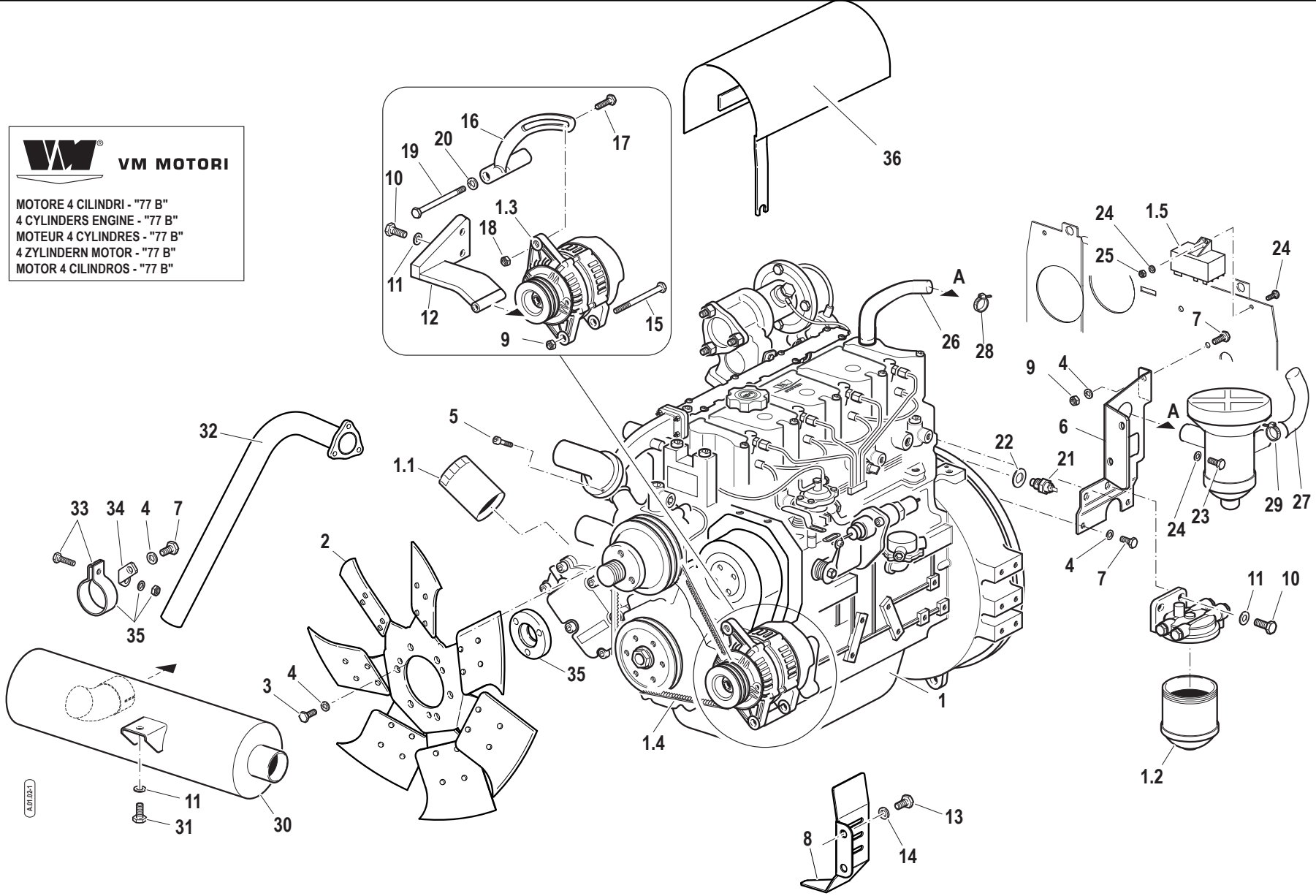

Pos.	Code	Q.ty	Description	Notes
1	41U60000	1	MOT.VM D704TE2.21A 60KW 77B/4	
1.1	58171199	1	FILTER INSERT	
1.2	58171200	1	FILTER INSERT	
1.3	59900344	1	ALTERNATOR	
1.4	59900766	1	BELT	
1.5	59900345	1	CENTRAL PROCESSING UNIT	
10	31112219	5	SCREW TE M10X25 UNI 5739	
11	F0843755000	6	WASHER 10	
12	59077318	1	SUPPORT	
13	31112082	2	SCREW TE M6X12 UNI 5739 8G	
14	31411064	2	WASHER 6,4x12,5	
15	31112174	1	SCREW TE M8X110 UNI 5737 8.8	
16	59076688	1	ROD	
17	31112153	1	SCREW TE M8X35 UNI 5739 8G	
18	31421083	1	WASHER	
19	F0864335020	1	SCREW M14X120 UNI 5737	
2	58178646	1	FAN	
20	31421251	1	WASHER	
21	58175773	1	ELECTRONICAL THERMOMETER	
22	F0844030070	1	COPPER WASHER 16,0x22/1,5	
23	31112090	2	SCREW TE M6X16 UNI 5739 8G	
24	F0843570000	2	WASHER 6	
25	31211060	2	NUT M6	
26	55176744	1	PIPE	
27	58177400	1	OIL PIPE	
28	F0817500400	3	CLAMP 024,1-706R	
29	F0817500200	1	CLAMP 015,7-706R	
3	F0862694000	3	SCREW M8X170 UNI 5737	
30	58176618	1	EXHAUST SILENCER	
31	31112210	1	SCREW TE M10X20 UNI 5739	
32	59076619	1	EXHAUST	
33	58175121	1	COLLAR	
34	56177183	1	REINFORCED STRAP	
35	56178649	1	SPACER	

SERIAL

ENGINE
Engine: 85 CV

CODE REV

A.01.02_1_45599

VM MOTORI

MOTORE 4 CILINDRI - "77 B"
 4 CYLINDERS ENGINE - "77 B"
 MOTEUR 4 CYLINDRES - "77 B"
 4 ZYLINDER MOTOR - "77 B"
 MOTOR 4 CILINDROS - "77 B"

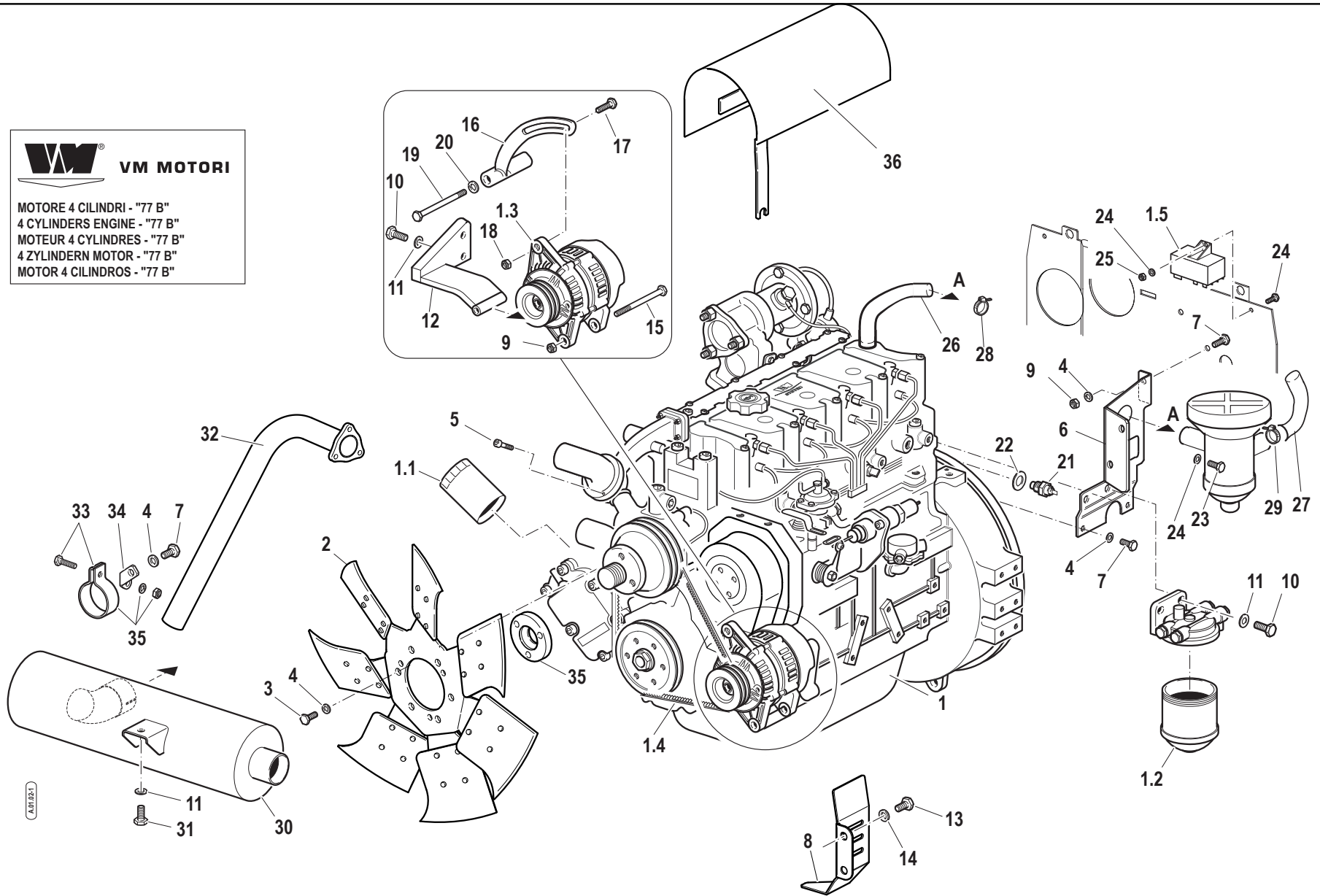

Pos.	Code	Q.ty	Description	Notes
36	59076682	1	GUARD	
4	F0843643060	7	WASHER 8	
5	F0862479035	1	SCREW M6X16 7380	
6	59079167	1	RETAINER	
7	31111151	4	SCREW TE M8X16 UNI 5739 8G	
8	56177979	1	SHIELD	
9	31211080	2	NUT M8	

SERIAL

ENGINE
Engine: 85 CV

CODE REV

A.01.02_1_45599

VM MOTORI

MOTORE 4 CILINDRI - "33 C"
 4 CYLINDERS ENGINE - "33 C"
 MOTEUR 4 CYLINDRES - "33 C"
 4 ZYLINDER MOTOR - "33 C"
 MOTOR 4 CILINDROS - "33 C"

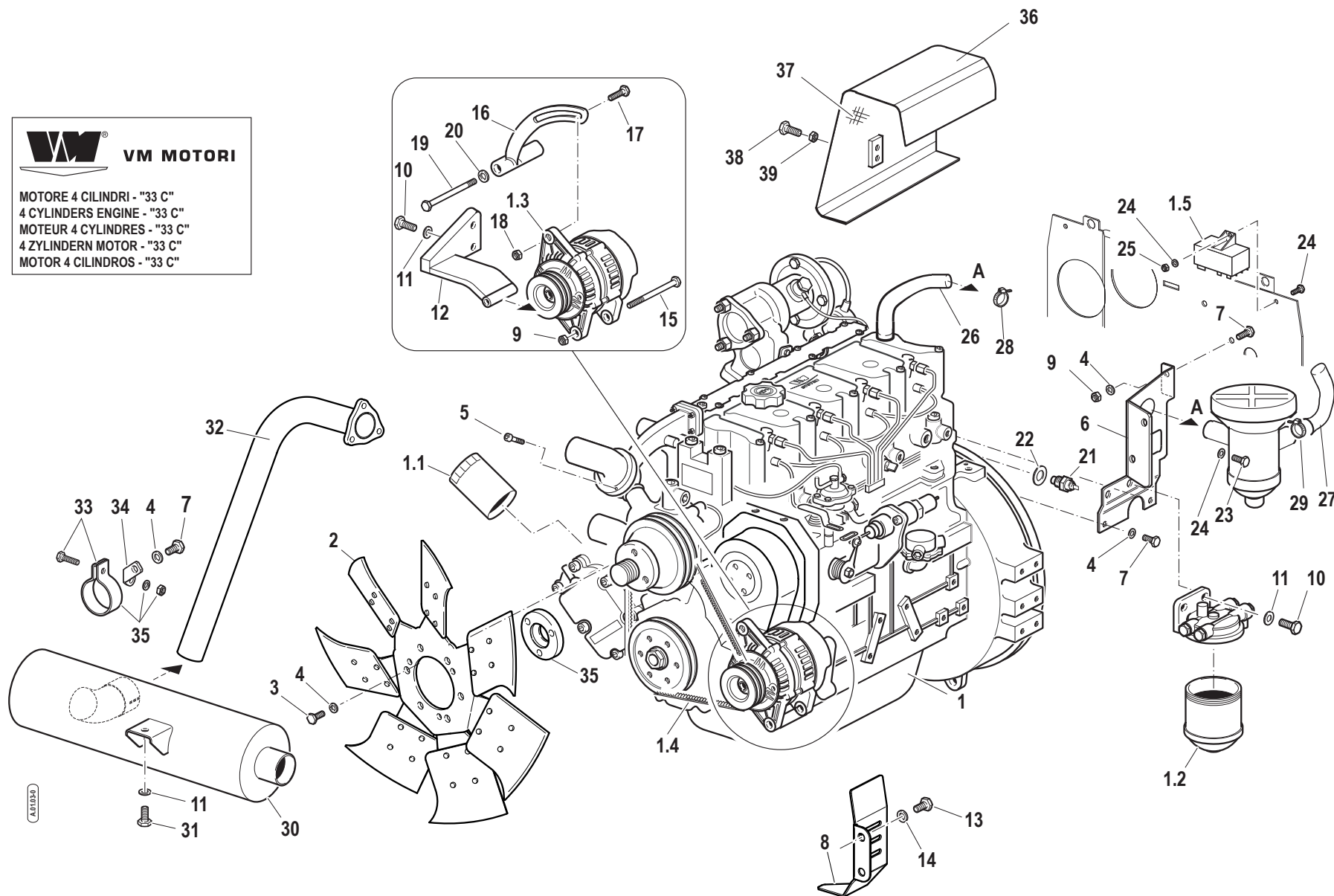

Pos.	Code	Q.ty	Description	Notes
1	41U70000	1	MOT.VM D754TE2.21A 67KW 33C/4	
1.1	58171199	1	FILTER INSERT	
1.2	58171200	1	FILTER INSERT	
1.3	59900344	1	ALTERNATOR	
1.4	59900766	1	BELT	
1.5	59900345	1	CENTRAL PROCESSING UNIT	
10	31112219	5	SCREW TE M10X25 UNI 5739	
11	F0843755000	6	WASHER 10	
12	59077318	1	SUPPORT	
13	31112082	2	SCREW TE M6X12 UNI 5739 8G	
14	31411064	2	WASHER 6,4x12,5	
15	31112174	1	SCREW TE M8X110 UNI 5737 8.8	
16	59076688	1	ROD	
17	31112153	1	SCREW TE M8X35 UNI 5739 8G	
18	31421083	1	WASHER	
19	F0864335020	1	SCREW M14X120 UNI 5737	
2	58178646	1	FAN	
20	31421251	1	WASHER	
21	58175773	1	ELECTRONICAL THERMOMETER	
22	F0844030070	1	COPPER WASHER 16,0x22/1,5	
23	31112090	2	SCREW TE M6X16 UNI 5739 8G	
24	F0843570000	2	WASHER 6	
25	31211060	2	NUT M6	
26	55176744	1	PIPE	
27	58177400	1	OIL PIPE	
28	F0817500400	3	CLAMP 024,1-706R	
29	F0817500200	1	CLAMP 015,7-706R	
3	F0862694000	3	SCREW M8X170 UNI 5737	
30	58176618	1	EXHAUST SILENCER	
31	31112210	1	SCREW TE M10X20 UNI 5739	
32	59076619	1	EXHAUST	
33	58175121	1	COLLAR	
34	56177183	1	REINFORCED STRAP	
35	56178649	1	SPACER	

SERIAL

ENGINE
Engine: 95 CV

CODE REV

A.01.03_0_48930

VM MOTORI

MOTORE 4 CILINDRI - "33 C"
 4 CYLINDERS ENGINE - "33 C"
 MOTEUR 4 CYLINDRES - "33 C"
 4 ZYLINDER MOTOR - "33 C"
 MOTOR 4 CILINDROS - "33 C"

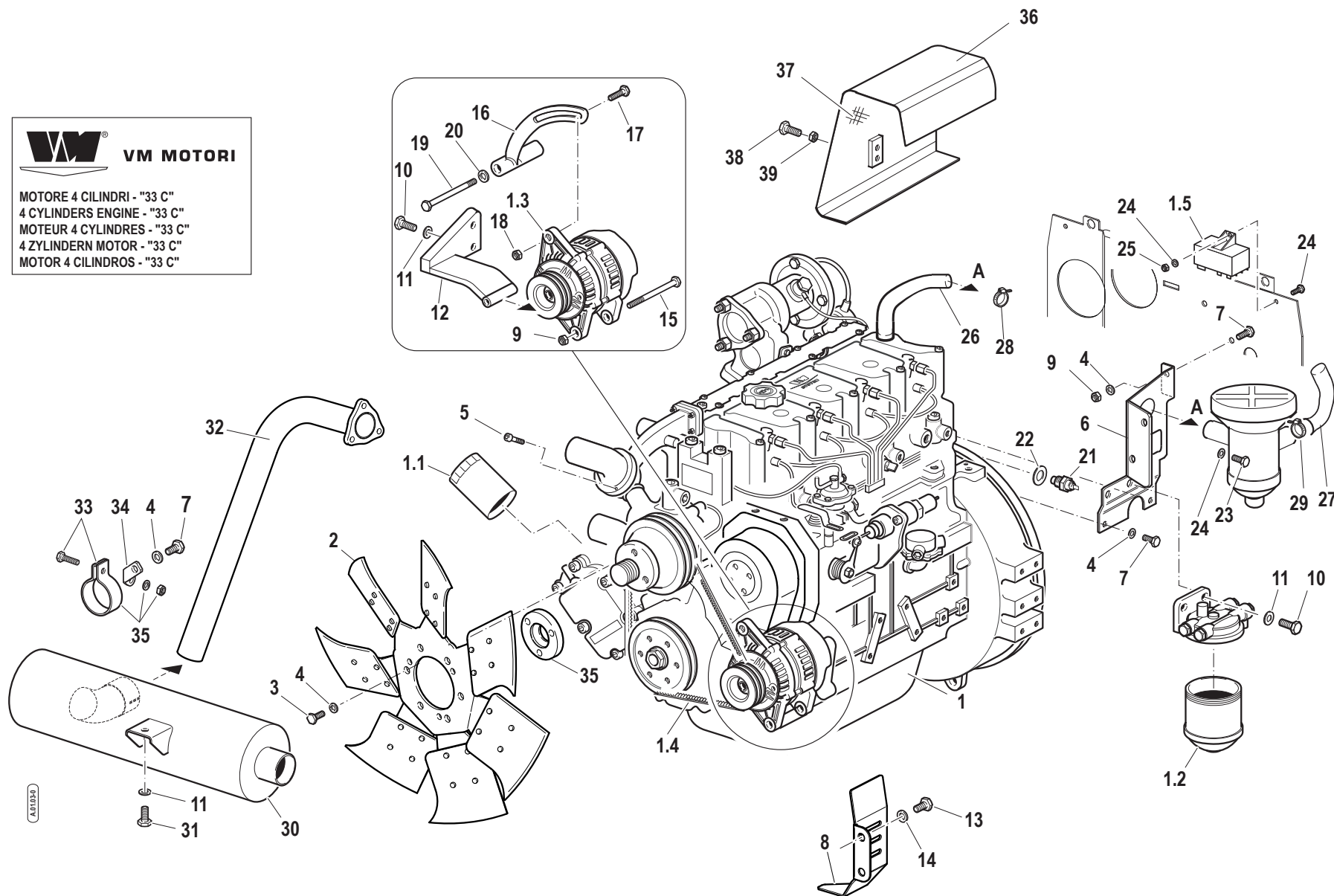

Pos.	Code	Q.ty	Description	Notes
36	59077480	1	GUARD	
37	58077484	1	LINING	
38	F0838384000	1	STUD BOLT M10X25 UNI 5911 8.8	
39	31215100	1	NUT M10	
4	F0843643060	7	WASHER 8	
5	F0862479035	1	SCREW M6X16 7380	
6	59079167	1	RETAINER	
7	31111151	4	SCREW TE M8X16 UNI 5739 8G	
8	56177979	1	SHIELD	
9	31211080	2	NUT M8	

VM MOTORI

MOTORE 4 CILINDRI - "33 C"
 4 CYLINDERS ENGINE - "33 C"
 MOTEUR 4 CYLINDRES - "33 C"
 4 ZYLINDER MOTOR - "33 C"
 MOTOR 4 CILINDROS - "33 C"

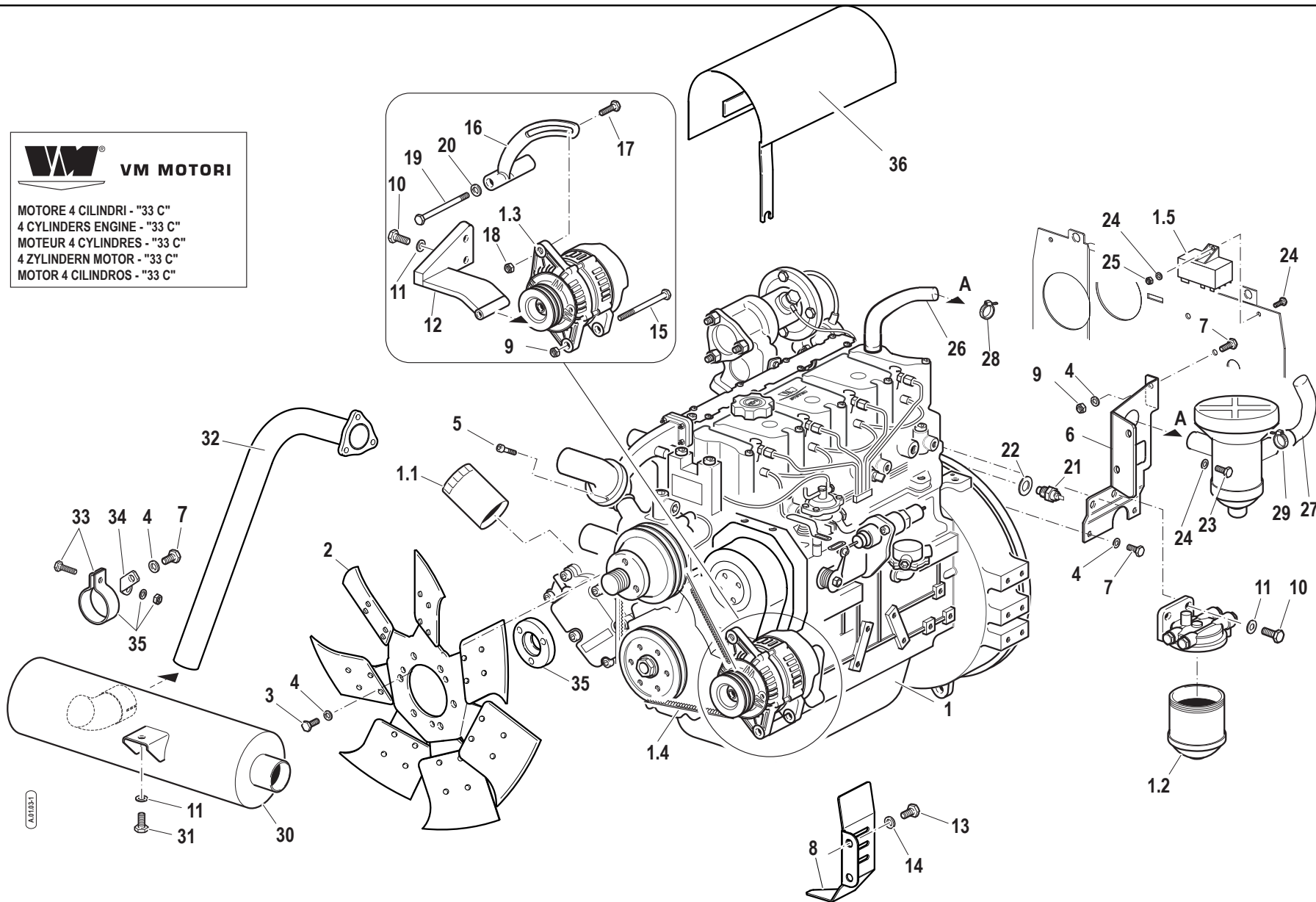

Pos.	Code	Q.ty	Description	Notes
1	41U70000	1	MOT.VM D754TE2.21A 67KW 33C/4	
1.1	58171199	1	FILTER INSERT	
1.2	58171200	1	FILTER INSERT	
1.3	59900344	1	ALTERNATOR	
1.4	59900766	1	BELT	
1.5	59900345	1	CENTRAL PROCESSING UNIT	
10	31112219	5	SCREW TE M10X25 UNI 5739	
11	F0843755000	6	WASHER 10	
12	59077318	1	SUPPORT	
13	31112082	2	SCREW TE M6X12 UNI 5739 8G	
14	31411064	2	WASHER 6,4x12,5	
15	31112174	1	SCREW TE M8X110 UNI 5737 8.8	
16	59076688	1	ROD	
17	31112153	1	SCREW TE M8X35 UNI 5739 8G	
18	31421083	1	WASHER	
19	F0864335020	1	SCREW M14X120 UNI 5737	
2	58178646	1	FAN	
20	31421251	1	WASHER	
21	58175773	1	ELECTRONICAL THERMOMETER	
22	F0844030070	1	COPPER WASHER 16,0x22/1,5	
23	31112090	2	SCREW TE M6X16 UNI 5739 8G	
24	F0843570000	2	WASHER 6	
25	31211060	2	NUT M6	
26	55176744	1	PIPE	
27	58177400	1	OIL PIPE	
28	F0817500400	3	CLAMP 024,1-706R	
29	F0817500200	1	CLAMP 015,7-706R	
3	F0862694000	3	SCREW M8X170 UNI 5737	
30	58176618	1	EXHAUST SILENCER	
31	31112210	1	SCREW TE M10X20 UNI 5739	
32	59076619	1	EXHAUST	
33	58175121	1	COLLAR	
34	56177183	1	REINFORCED STRAP	
35	56178649	1	SPACER	

SERIAL

ENGINE
Engine: 95 CV

CODE REV

A.01.03_1_45644

VM MOTORI

MOTORE 4 CILINDRI - "33 C"
 4 CYLINDERS ENGINE - "33 C"
 MOTEUR 4 CYLINDRES - "33 C"
 4 ZYLINDER MOTOR - "33 C"
 MOTOR 4 CILINDROS - "33 C"

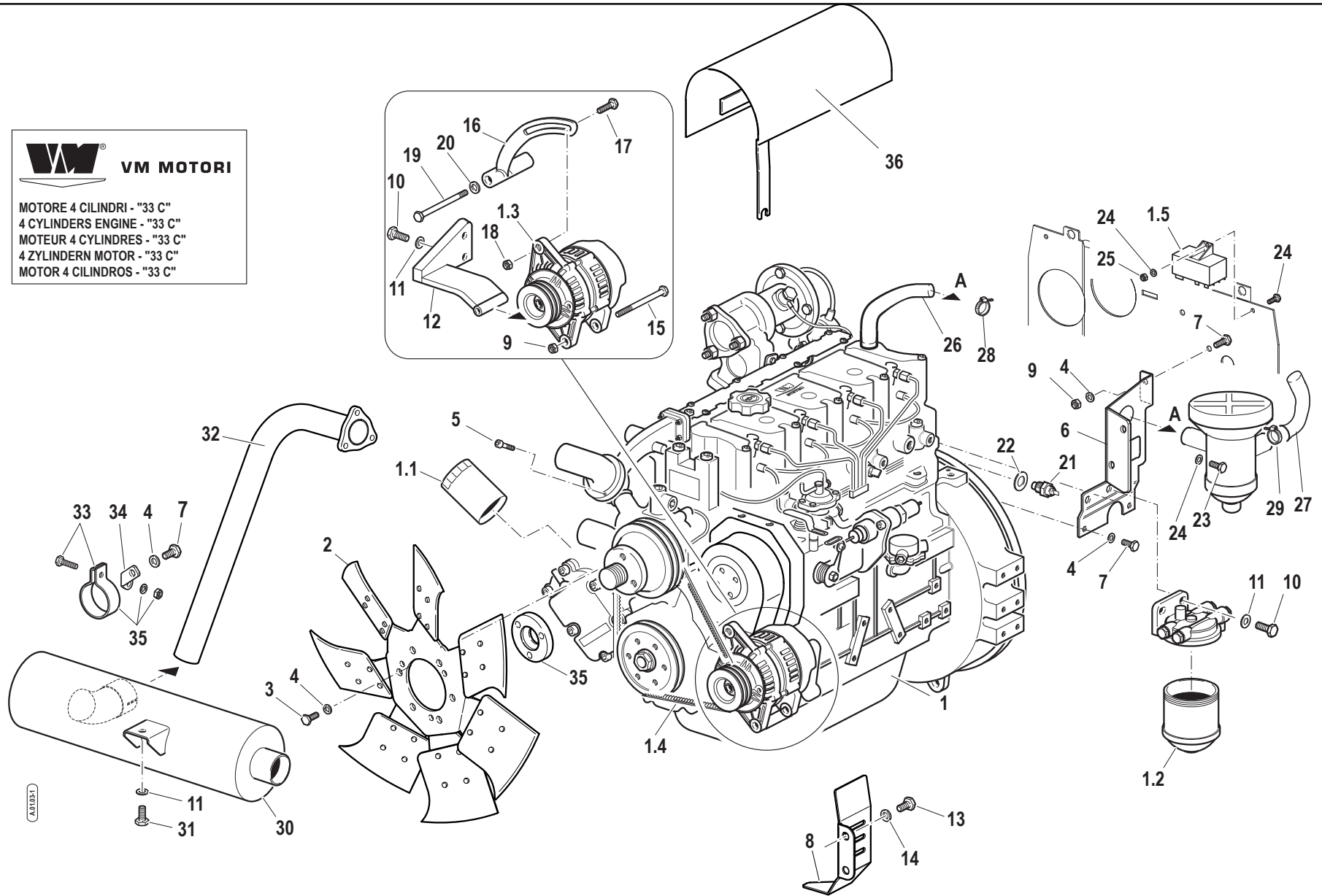

Pos.	Code	Q.ty	Description	Notes
36	59076682	1	GUARD	
4	F0843643060	7	WASHER 8	
5	F0862479035	1	SCREW M6X16 7380	
6	59079167	1	RETAINER	
7	31111151	4	SCREW TE M8X16 UNI 5739 8G	
8	56177979	1	SHIELD	
9	31211080	2	NUT M8	

SERIAL

ENGINE
Engine: 95 CV

CODE REV

A.01.03_1_45644

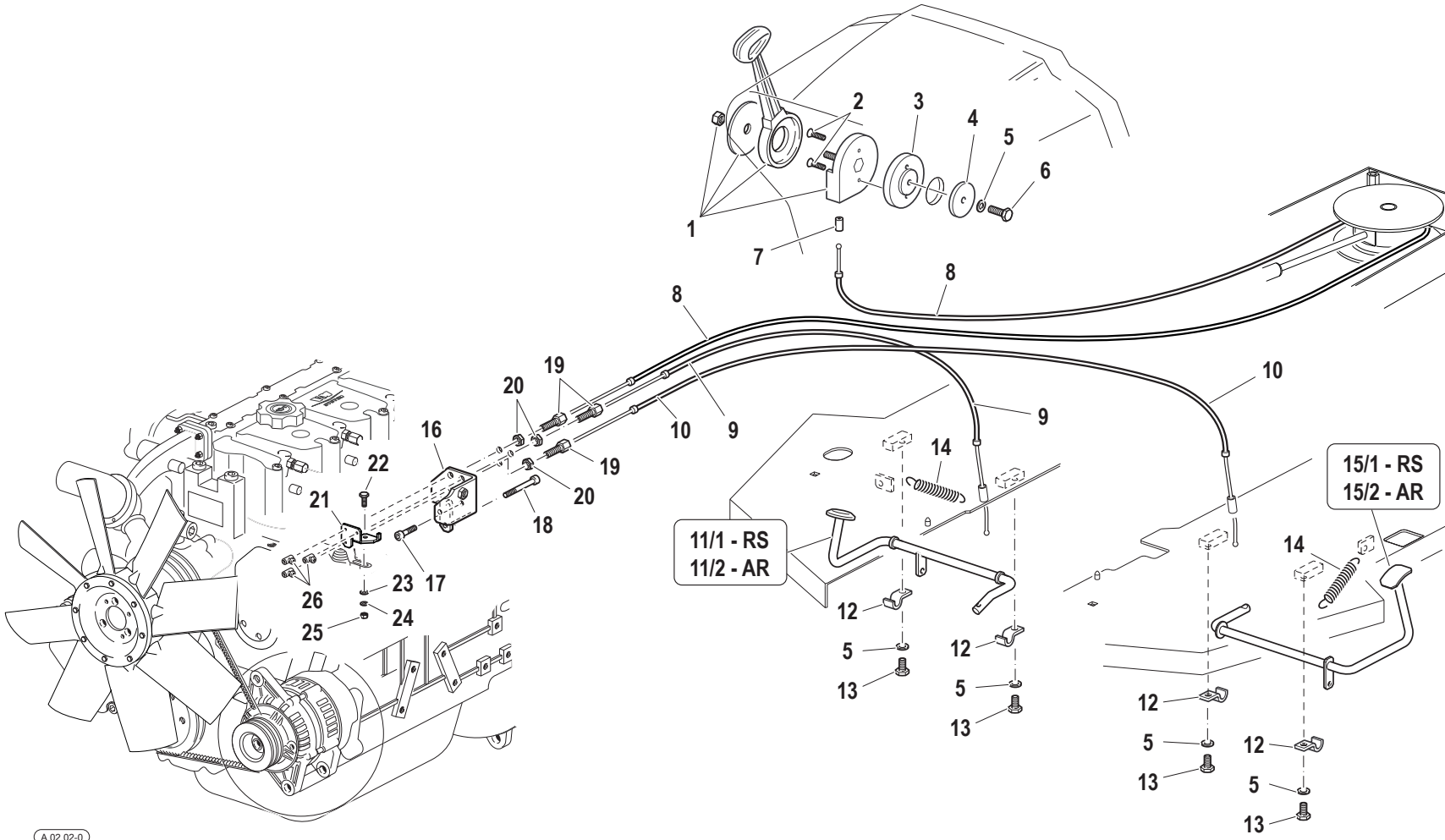

Pos.	Code	Q.ty	Description	Notes
1	F0828029070	1	ACCELERATOR	
10	58072075	1	CABLE	
11/1	59074346	1	ACCEL. PEDAL	
11/2	59073681	1	ACCEL. PEDAL	
12	56071768	4	PLATE	
13	31112148	2	SCREW TE M8X18 UNI 5739 8G	
14	F0831125000	2	SPRING	
15/1	59074347	1	ACCEL. PEDAL	
15/2	59074213	1	ACCEL. PEDAL	
16	56174661	1	BRACKET	
17	31152060	1	SCREW TCEI M6X30 UNI 5931	
18	31152068	1	SCREW TCEI M6X55 UNI 5931	
19	56177656	3	REGISTER	
2	31132562	2	SCREW TSVEI M6X16 UNI 5933	
20	31231080	3	NUT M8	
21	56177655	1	BRACKET	
22	31112051	1	SCREW TE M5X14 UNI 5739 8G	
23	31411053	1	WASHER 5,3x10	
24	F0843561000	1	WASHER 5	
25	31211050	1	NUT M5	
26	58048002	3	CLAMPING SCREW	
3	56171877	1	FLANGE	
4	56171883	1	LOCK WASHER D.45x9/4	
5	F0843643060	5	WASHER 8	
6	31112150	1	SCREW TE M8X20 UNI 5739 8G	
7	F0858520000	1	SLEEVE	
8	58078631	1	CABLE	
9	58072074	1	CABLE	

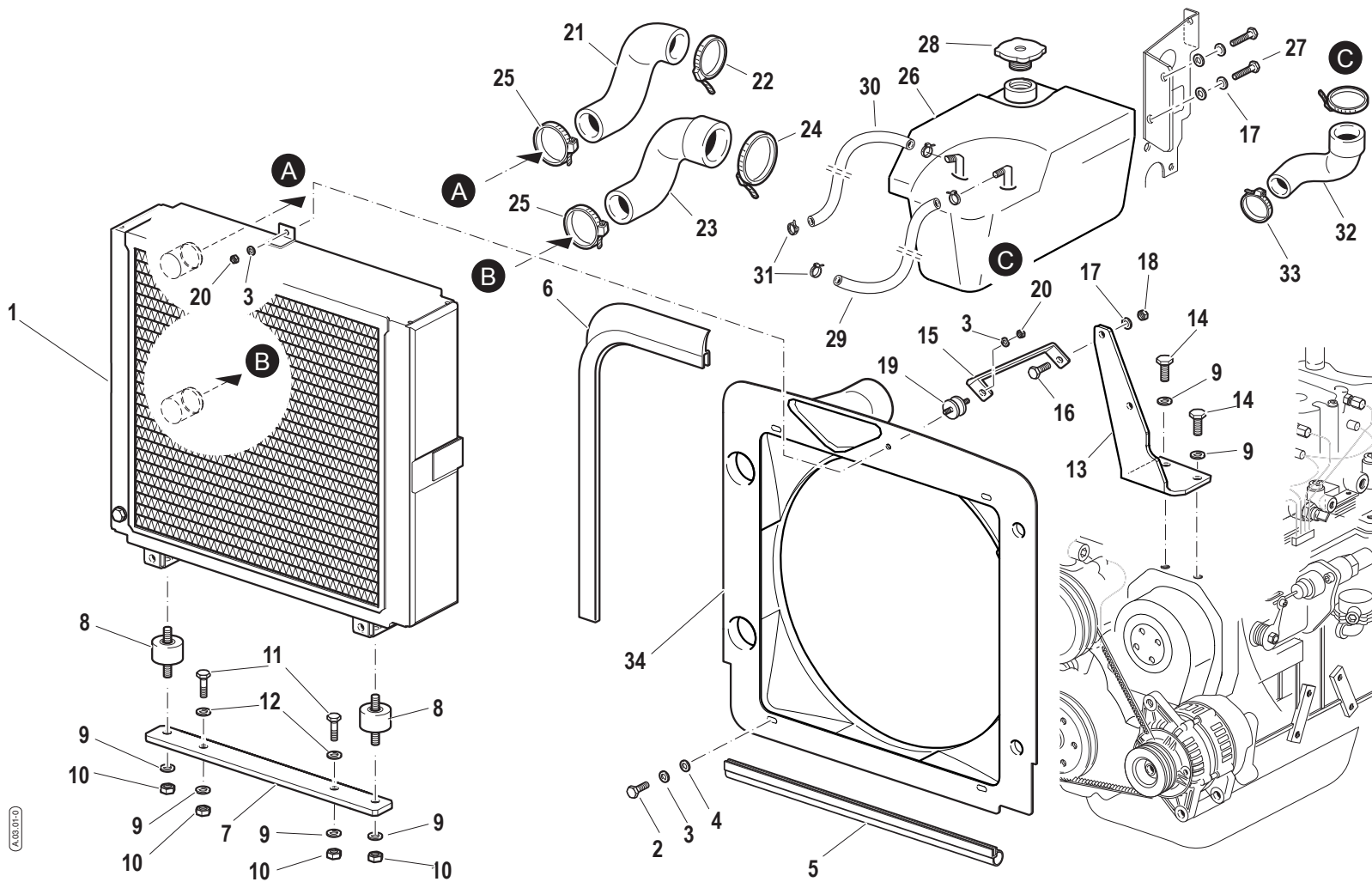

Pos.	Code	Q.ty	Description	Notes
1	58178586	1	RADIATOR	
10	F0814632000	4	NUT M10	
11	31112212	2	SCREW TE M10X35 UNI 5739	
12	56178806	2	SPACER	
13	59076684	1	FIXING BRACKET	
14	31152103	1	SCREW TCEI M10X25 UNI 5931	
15	56176691	1	FIXING BRACKET	
16	31112151	1	SCREW TE M8X25 UNI 5739 8G	
17	F0843643060	3	WASHER 8	
18	31211080	1	NUT M8	
19	F0849206005	1	SILENT-BLOCK	
2	31112082	4	SCREW TE M6X12 UNI 5739 8G	
20	F0814545000	2	NUT M6	
21	55174632	1	SLEEVE	
22	F0817500500	1	CLAMP 048,5-706R	
23	55177639	1	SLEEVE	
24	F0817500700	1	CLAMP 057,5-706R	
25	F0817500470	2	CLAMP	
26	P23634000000	1	CUP	
27	31111151	2	SCREW TE M8X16 UNI 5739 8G	
28	P23622000000	1	PLUG	
29	58078677	1	VENT HOSE	
3	F0843570000	6	WASHER 6	
30	58075873	1	VENT HOSE	
31	F0817500200	4	CLAMP 015,7-706R	
32	58077132	1	PIPE	
33	F0817500400	2	CLAMP 024,1-706R	
34	58178638	1	DUCT	
35	31111091	4	SCREW E M6X14 UNI 5739 8G	
36	31211060	2	NUT M6	
37	31411066	6	WASHER 6,6x18	
4	31411064	4	WASHER 6,4x12,5	
5	28174882	1	GASKET	
6	F0256809050	1	GASKET	

SERIAL

COOLER
Engine: 75 CV

CODE REV

A.03.01_0_45689

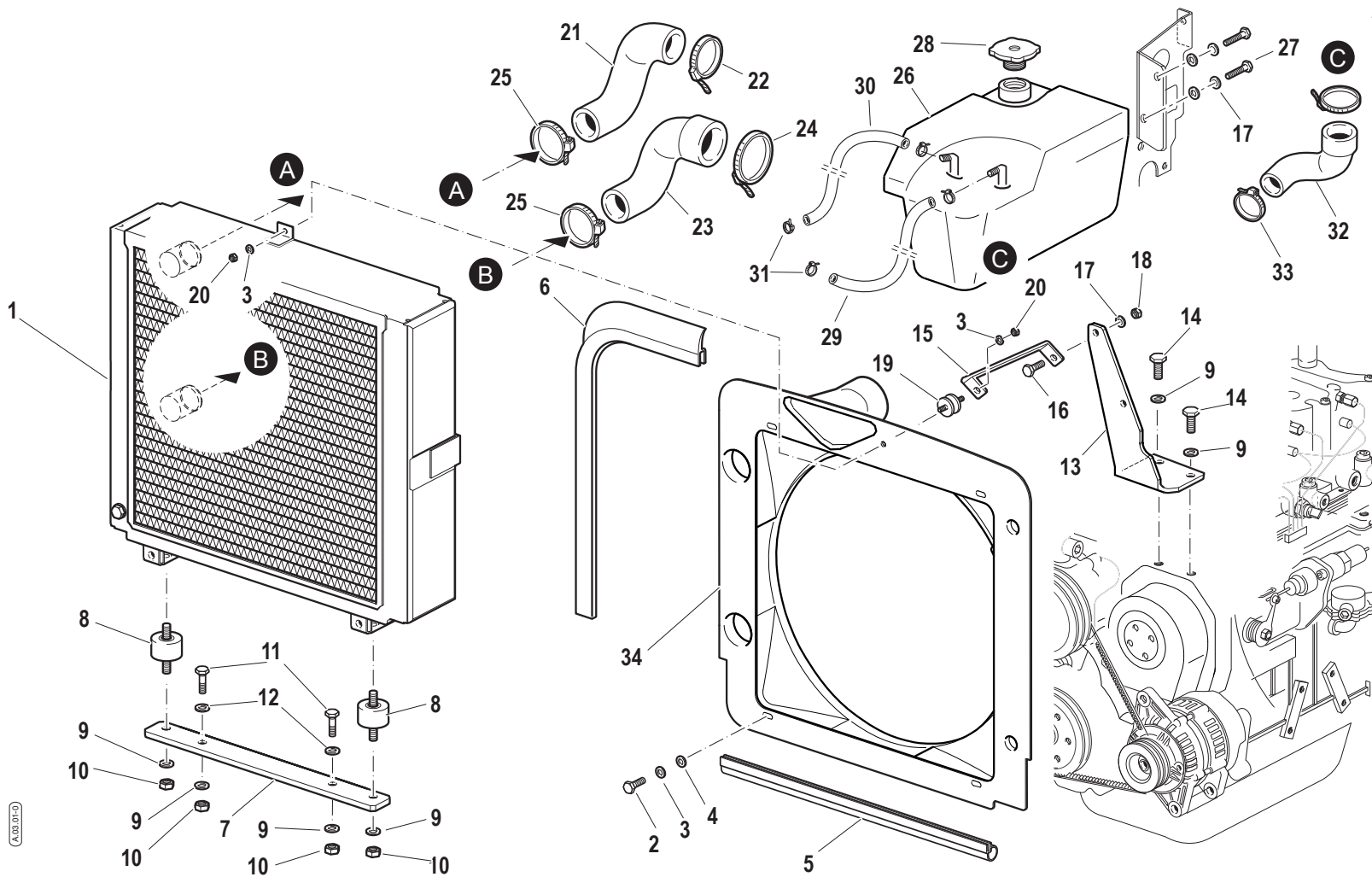

Pos.	Code	Q.ty	Description	Notes
7	56178805	1	BRACKET	
8	58174608	2	SILENT-BLOCK	
9	F0843755000	5	WASHER 10	

COOLER

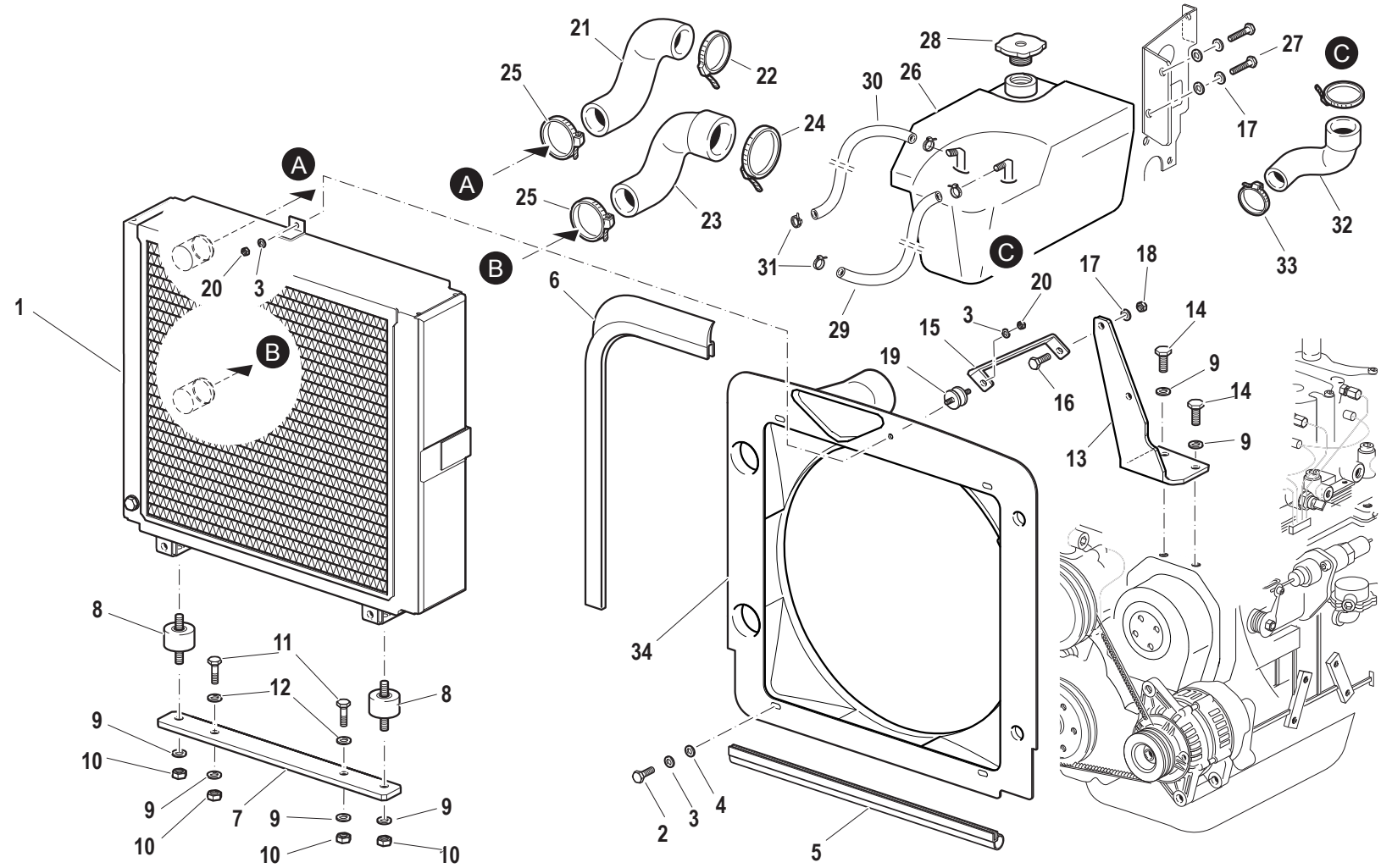

A.03.02.0

Pos.	Code	Q.ty	Description	Notes
1	58178585	1	RADIATOR	
10	F0814632000	4	NUT M10	
11	31112212	2	SCREW TE M10X35 UNI 5739	
12	56178806	2	SPACER	
13	59076684	1	FIXING BRACKET	
14	31152103	1	SCREW TCEI M10X25 UNI 5931	
15	56176691	1	FIXING BRACKET	
16	31112151	1	SCREW TE M8X25 UNI 5739 8G	
17	F0843643060	3	WASHER 8	
18	31211080	1	NUT M8	
19	F0849206005	1	SILENT-BLOCK	
2	31112082	4	SCREW TE M6X12 UNI 5739 8G	
20	F0814545000	2	NUT M6	
21	55174632	1	SLEEVE	
22	F0817500500	1	CLAMP 048,5-706R	
23	55177639	1	SLEEVE	
24	F0817500700	1	CLAMP 057,5-706R	
25	F0817500470	2	CLAMP	
26	P23634000000	1	CUP	
27	31111151	2	SCREW TE M8X16 UNI 5739 8G	
28	P23622000000	1	PLUG	
29	58078677	1	VENT HOSE	
3	F0843570000	6	WASHER 6	
30	58075873	1	VENT HOSE	
31	F0817500200	4	CLAMP 015,7-706R	
32	58077132	1	PIPE	
33	F0817500400	2	CLAMP 024,1-706R	
34	58178638	1	DUCT	
35	31111091	4	SCREW E M6X14 UNI 5739 8G	
36	31211060	2	NUT M6	
37	31411066	6	WASHER 6,6x18	
4	31411064	4	WASHER 6,4x12,5	
5	28174882	1	GASKET	
6	F0256809050	1	GASKET	

SERIAL

COOLER
 Engine: 85 CV, 95 CV

CODE REV

A.03.02_0_45727

COOLER

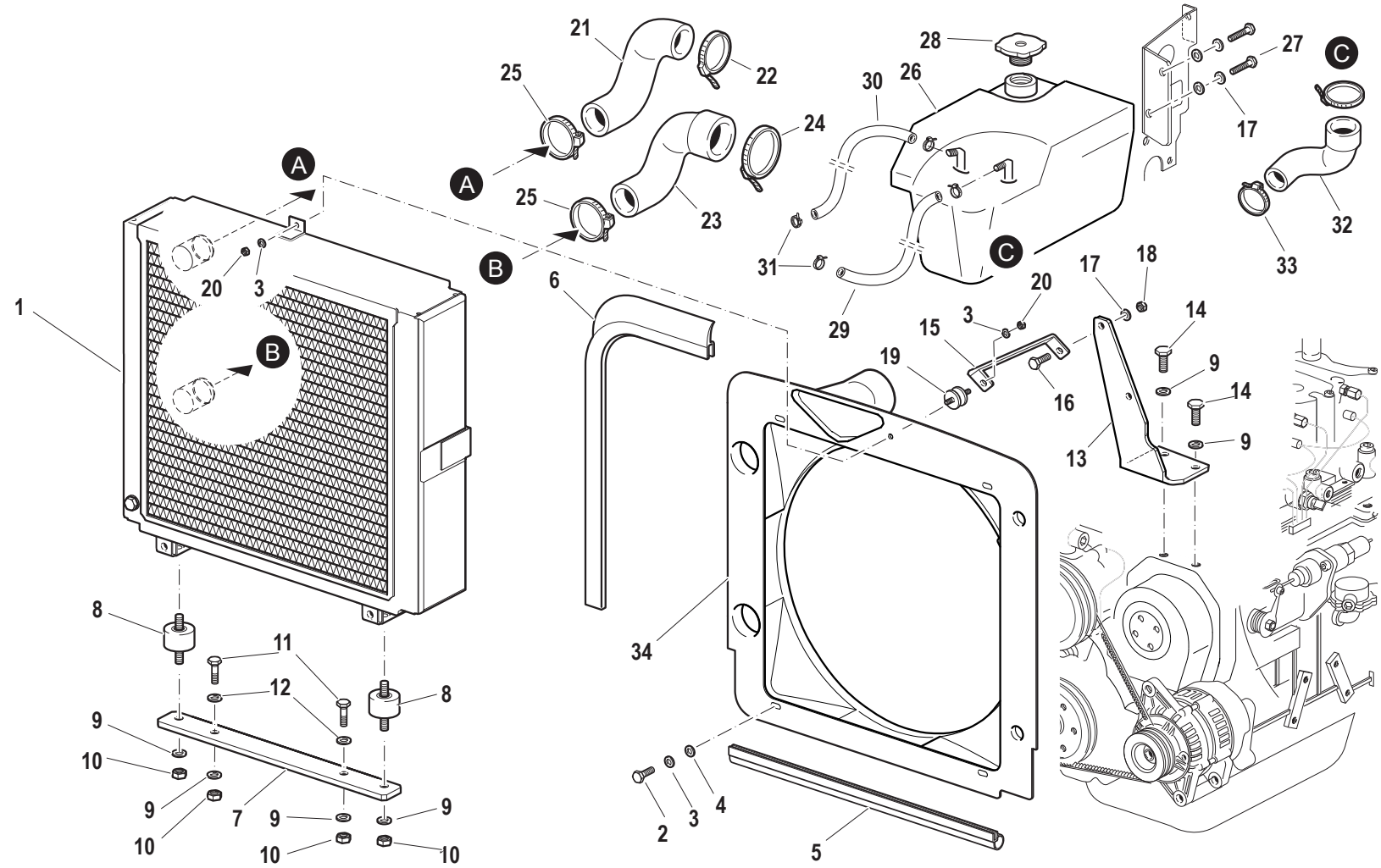

A.03.02.0

Pos.	Code	Q.ty	Description	Notes
7	56178805	1	BRACKET	
8	58174608	2	SILENT-BLOCK	
9	F0843755000	5	WASHER 10	

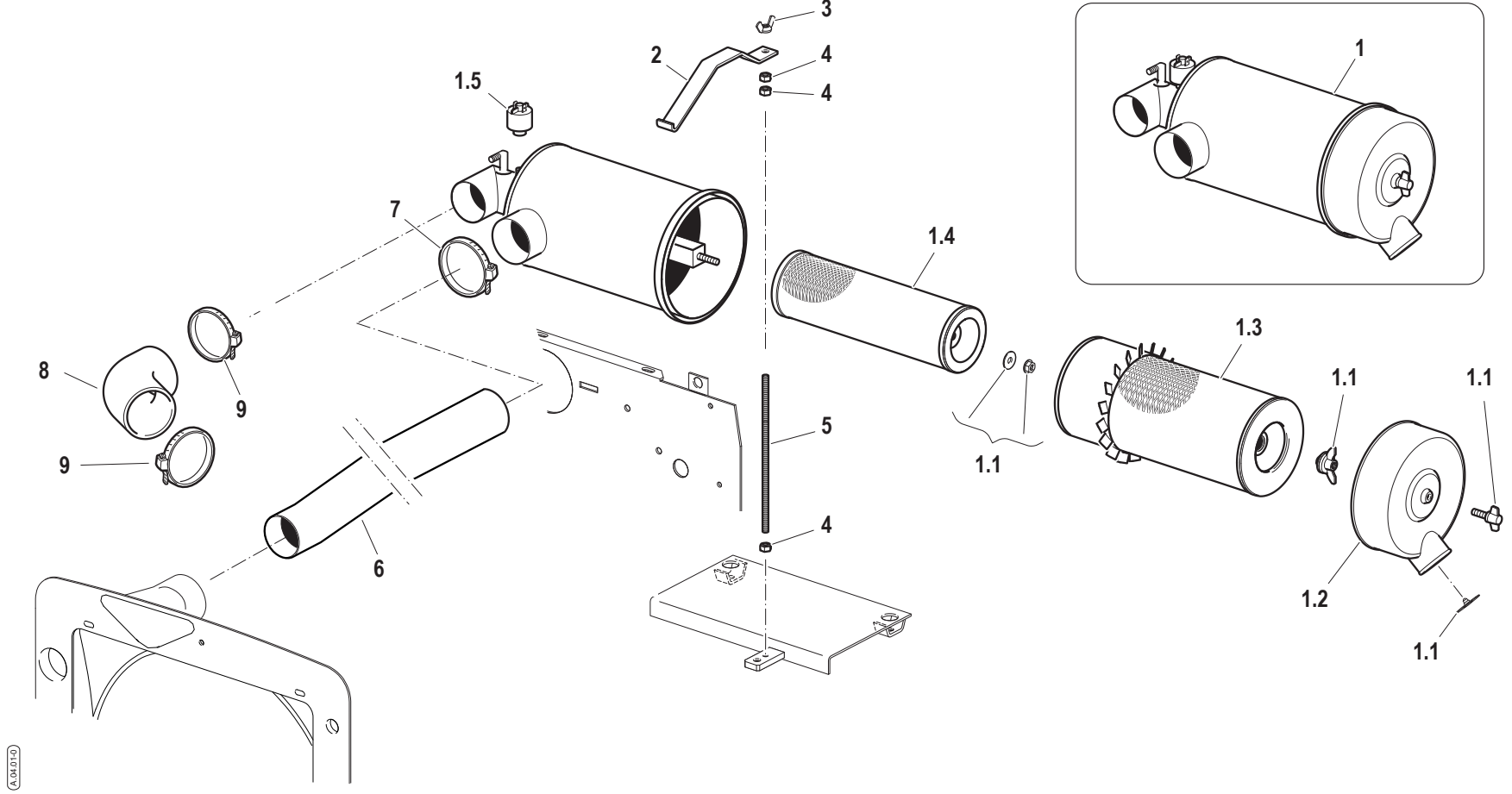

Pos.	Code	Q.ty	Description	Notes
1	58176755	1	AIR FILTER	
1.1	59900353	1	KIT	
1.2	59900347	1	COVER	
1.3	58171028	1	CARTOUCHE	
1.4	58171027	1	CARTOUCHE	
1.5	58175122	1	DIGITAL INSTRUMENT	
2	56174636	1	FIXING BRACKET	
3	31200501	1	NUT M8	
4	31211080	3	NUT M8	
5	56174635	1	ROD	
6	58076753	1	SUCTION PIPE	
7	F0817501200	1	CLAMP 077,0-706R	
8	58076751	1	SLEEVE	
9	F0817501000	2	CLAMP 072,5-706R	

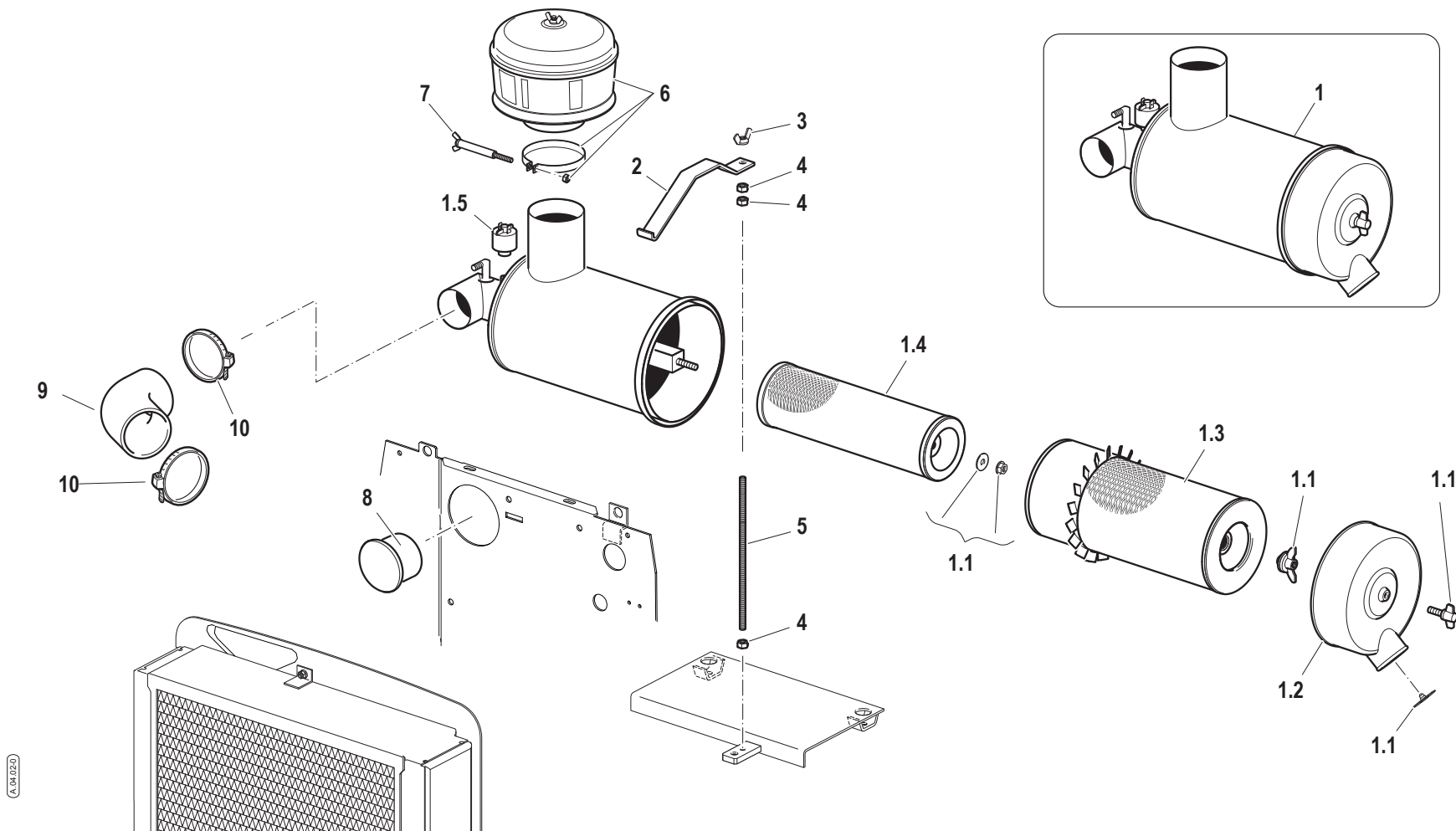

A.04.02.0

Pos.	Code	Q.ty	Description	Notes
1	58176898	1	AIR FILTER	
1.1	59900353	1	KIT	
1.2	59900347	1	COVER	
1.3	58171028	1	CARTOUCHE	
1.4	58171027	1	CARTOUCHE	
1.5	58175122	1	DIGITAL INSTRUMENT	
10	F0817501000	2	CLAMP 072,5-706R	
2	56174636	1	FIXING BRACKET	
3	31200501	1	NUT M8	
4	31211080	3	NUT M8	
5	56174635	1	ROD	
6	58171069	1	PRECLEANER	
7	59073184	1	SCREW	
8	57377317	1	PLUG	
9	58076751	1	SLEEVE	

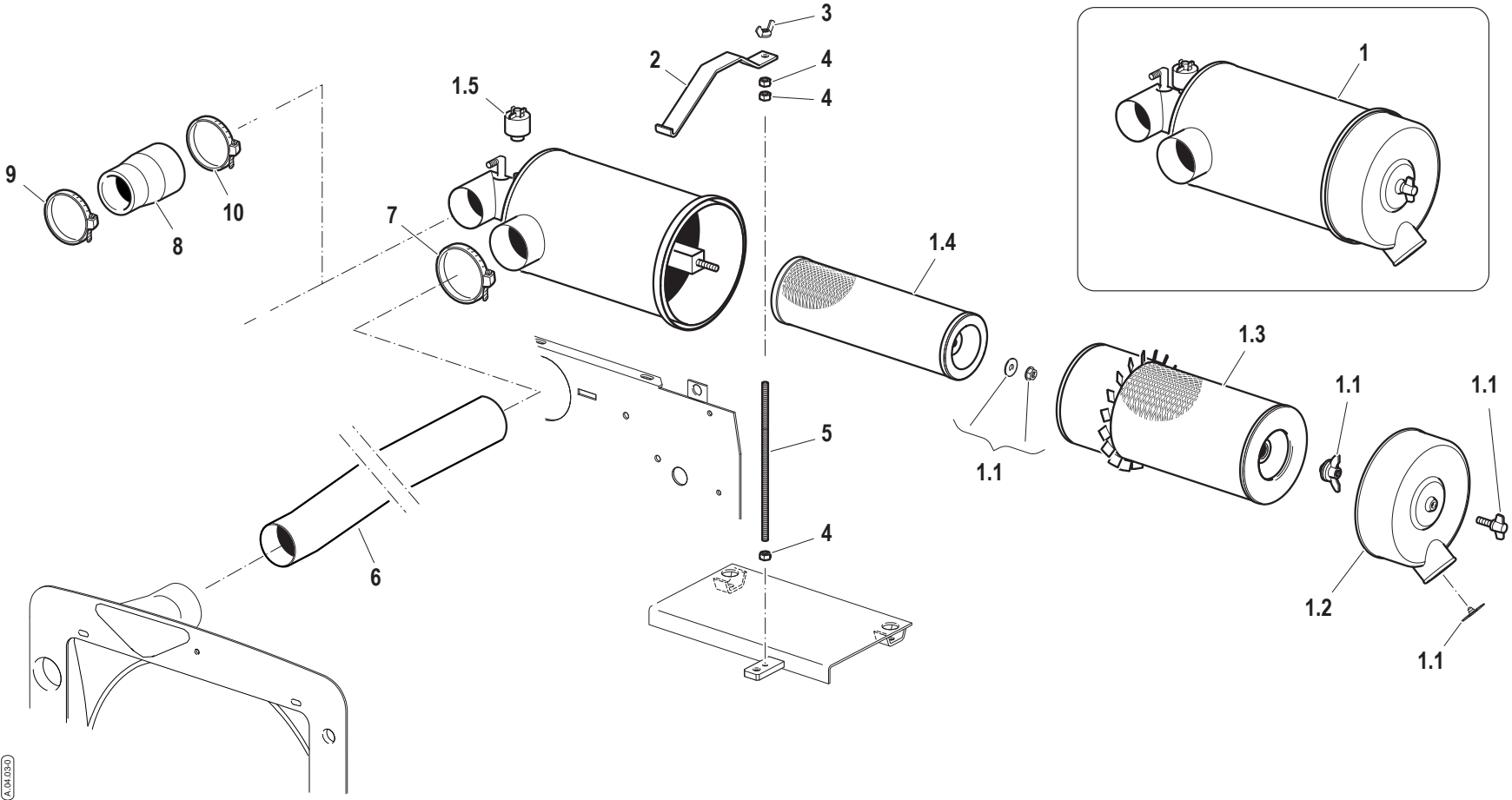

A.04.03.00

Pos.	Code	Q.ty	Description	Notes
1	58176755	1	AIR FILTER	
1.1	59900353	1	KIT	
1.2	59900347	1	COVER	
1.3	58171028	1	CARTOUCHE	
1.4	58171027	1	CARTOUCHE	
1.5	58175122	1	DIGITAL INSTRUMENT	
10	F0817500900	1	CLAMP 069,5-706R	
2	56174636	1	FIXING BRACKET	
3	31200501	1	NUT M8	
4	31211080	3	NUT M8	
5	56174635	1	ROD	
6	58076753	1	SUCTION PIPE	
7	F0817501200	1	CLAMP 077,0-706R	
8	58076750	1	SLEEVE	
9	F0817500800	1	CLAMP 062,0-706R	

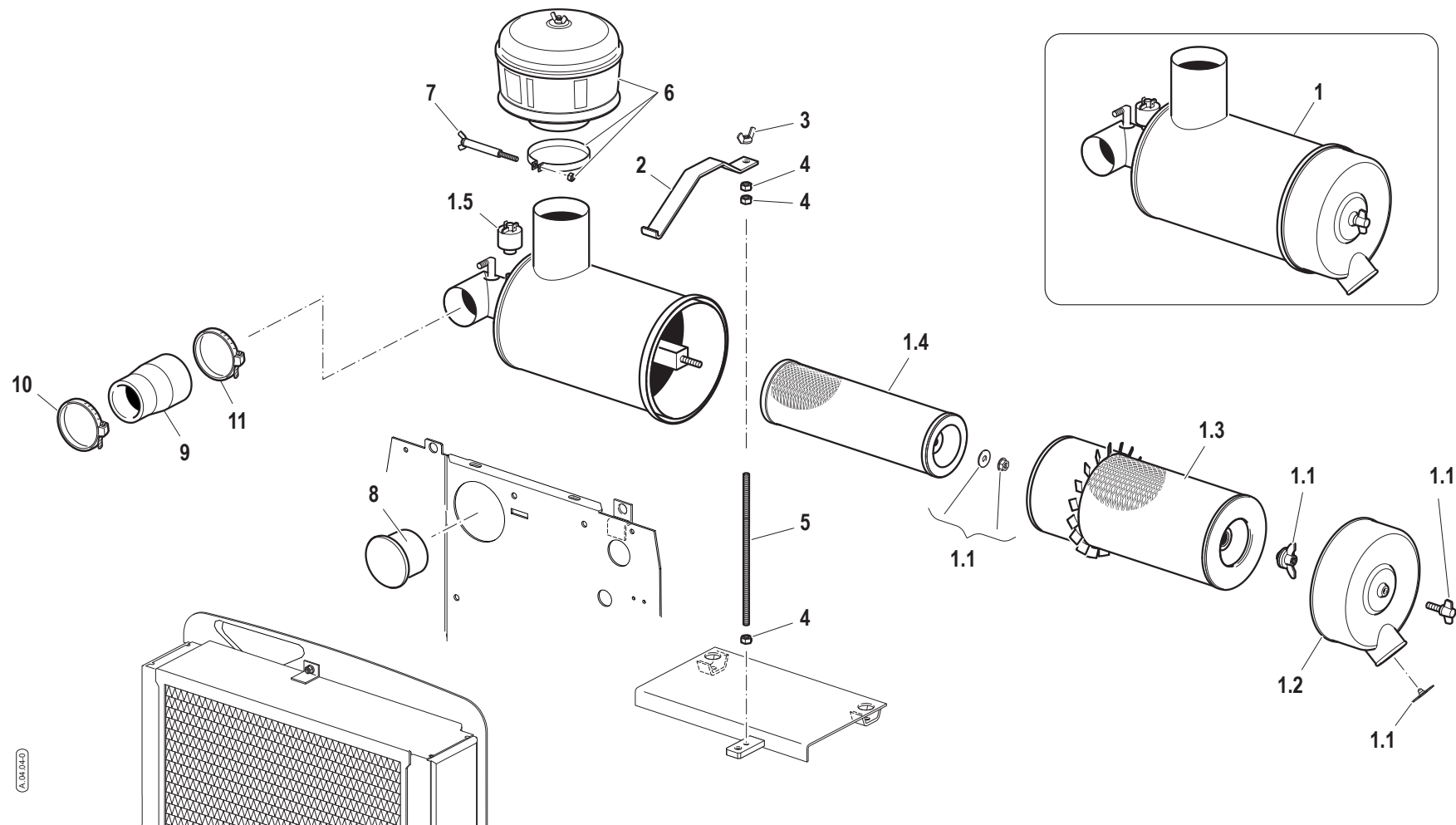

△ 04.04.12

Pos.	Code	Q.ty	Description	Notes
1	58176898	1	AIR FILTER	
1.1	59900353	1	KIT	
1.2	59900347	1	COVER	
1.3	58171028	1	CARTOUCHE	
1.4	58171027	1	CARTOUCHE	
1.5	58175122	1	DIGITAL INSTRUMENT	
10	F0817500800	1	CLAMP 062,0-706R	
11	F0817500900	1	CLAMP 069,5-706R	
2	56174636	1	FIXING BRACKET	
3	31200501	1	NUT M8	
4	31211080	3	NUT M8	
5	56174635	1	ROD	
6	58171069	1	PRECLEANER	
7	59073184	1	SCREW	
8	57377317	1	PLUG	
9	58076750	1	SLEEVE	

SERIAL

AIR FILTER WITH EXTERNAL AIR INTAKE

Engine: 85 CV, 95 CV

CODE REV

A.04.04_0_45812

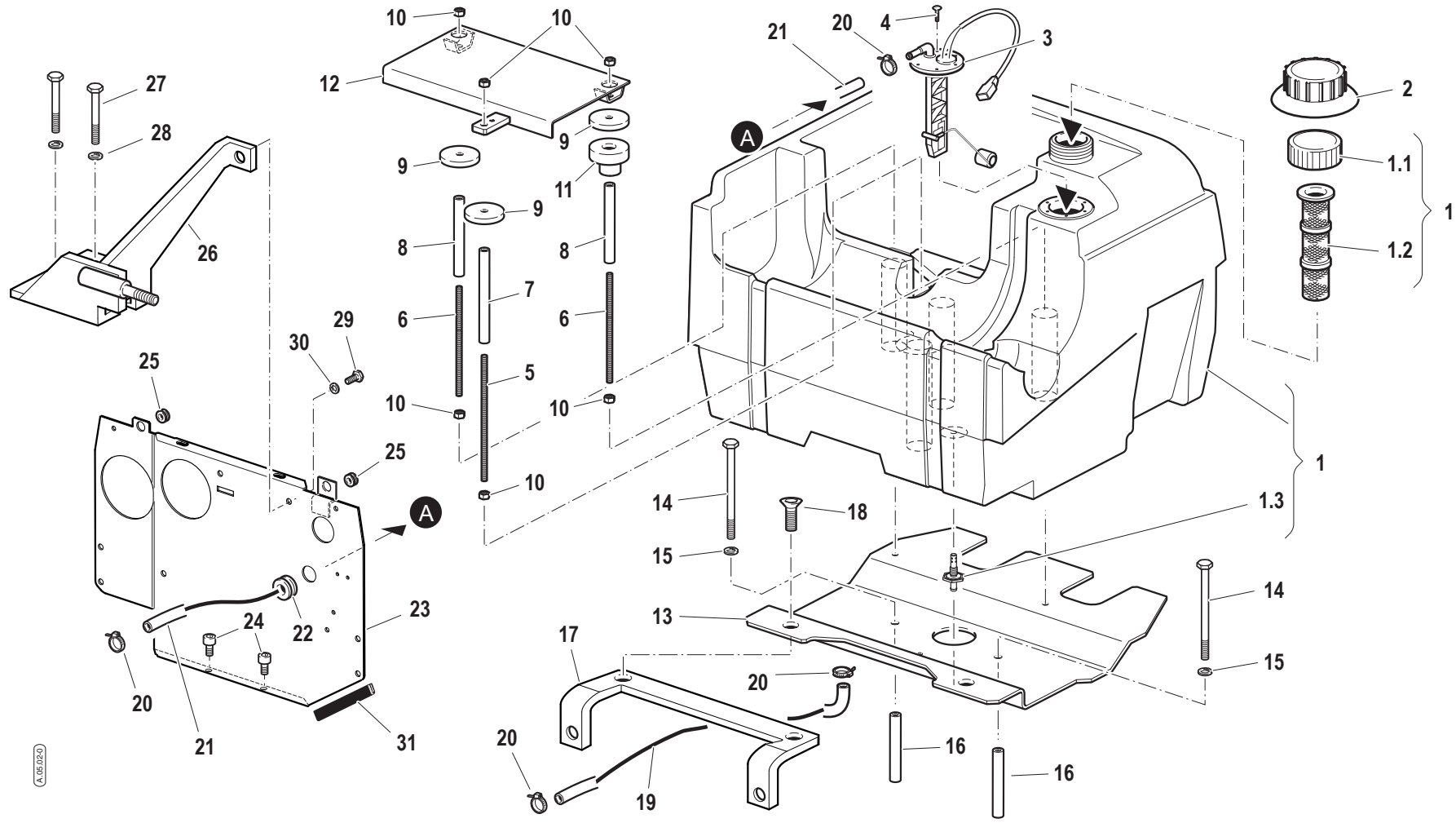

A.05.02_0

Pos.	Code	Q.ty	Description	Notes
1	55276745	1	TANK	
1.1	F0849500001	1	TANK COVER	
1.2	F0849500002	1	FILTER	
1.3	57174915	1	PIPE FITTING	
10	31211080	6	NUT M8	
11	58076752	3	STOPPER	
12	59076685	1	BATTERY SUPPORT	
13	59077934	1	SUPPORT	
14	31111218	2	SCREW TE M10X140 UNI 5737 8G	
15	F0843755000	2	WASHER 10	
16	56170276	2	SPACER	
17	59077935	1	FIXING BRACKET	
18	F0862481000	2	SCREW M8x16 UNI 5933	
19	58070690	1	PIPE	
2	57371900	1	LINING	
20	F0817500200	4	CLAMP 015,7-706R	
21	58074895	1	PIPE	
22	58171901	1	CABLE GLAND 15,5-24-32-2	
23	59076679	1	DIVISION	
24	F0862464050	2	SCREW UNI 5931	
25	F0825414000	2	CABLE GLAND 7-15-18,5-2,5	
26	59076686	1	BRACKET	
27	31112096	2	SCREW TE M6X85 UNI 5737 8G	
28	F0843570000	2	WASHER 6	
29	31111151	1	SCREW TE M8X16 UNI 5739 8G	
3	58170238	1	CONTROL	
30	F0843643060	1	WASHER 8	
31	F0256808000	1	FLAT BAND	
4	F0861867050	6	SCREW M4,2X19 DIN 7981	
5	56174635	1	ROD	
6	56077608	2	ROD	
7	56176716	1	SPACER	
8	56176696	2	SPACER D.14x9/155,5	
9	56176814	3	SPACER D.55x8/4	

SERIAL

FUEL TANK

CODE REV

A.05.02_0_45864

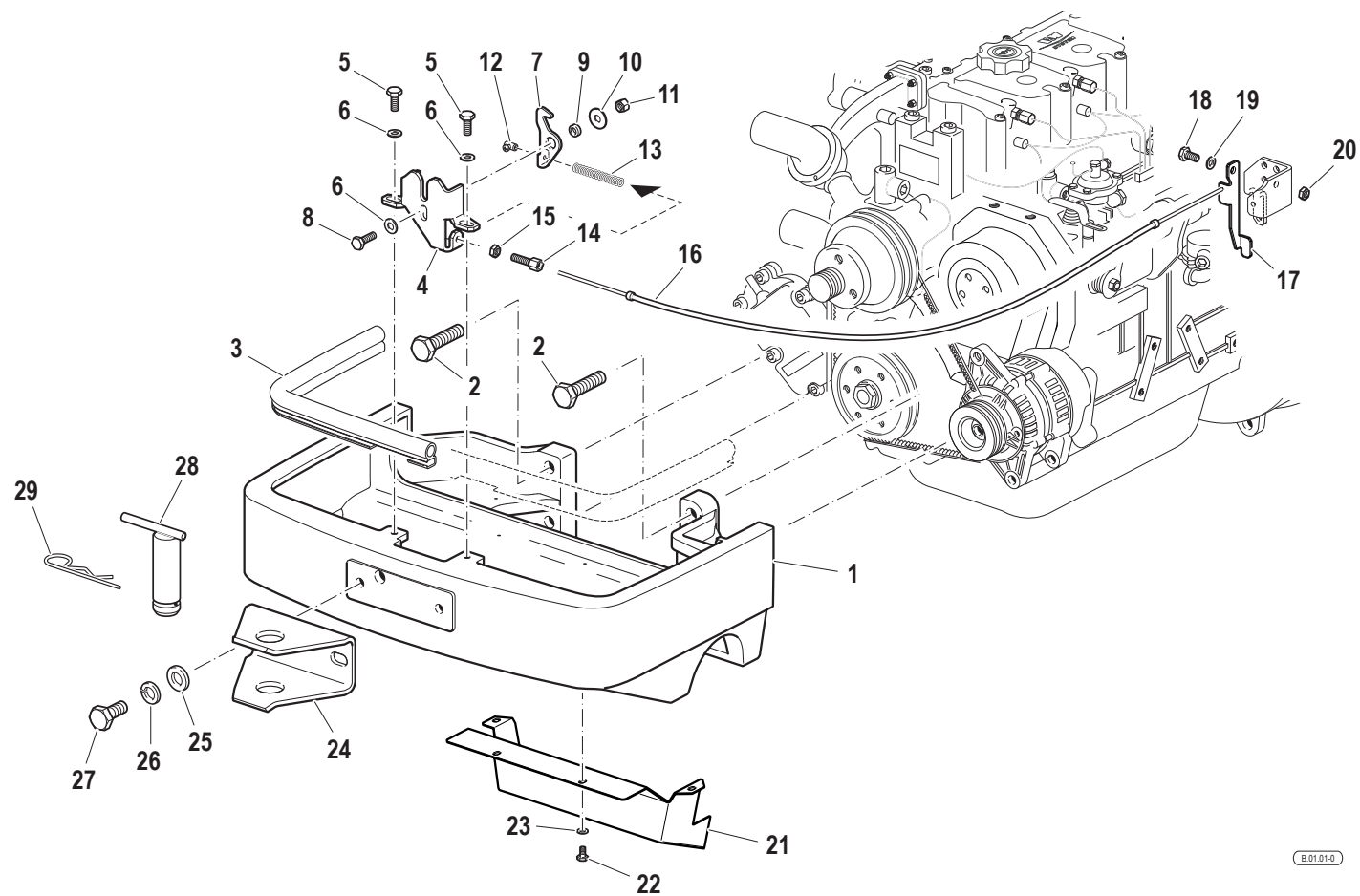
FRONT SUPPORT

Pos.	Code	Q.ty	Description	Notes
1	51176714	1	FRONT SUPPORT	
10	31411090	1	WASHER 9x24	
11	31241080	1	SELFLOCK NUT M8	
12	58048002	1	CLAMPING SCREW	
13	F0831065000	1	SPRING	
14	56177656	1	REGISTER	
15	31231080	1	NUT M8	
16	58074831	1	CABLE	
17	56177643	1	LEVER	
18	31111151	1	SCREW TE M8X16 UNI 5739 8G	
19	F0843643060	1	WASHER 8	
2	31111331	4	SCREW TE M14X50 UNI5739 8G	
20	F0814569000	1	NUT M8 UNI 5589 CL:8	
21	59076756	1	SHIELD	
22	31112082	12	SCREW TE M6X12 UNI 5739 8G	
23	F0843570000	12	WASHER 6	
24	56174873	1	TOW HOOK	
25	31112328	2	SCREW TE M14X35 UNI 5739	
26	F0843921030	2	WASHER 14	
27	31411150	2	WASHER 15x28	
28	59075283	1	PIN	
29	F0851497000	1	SPLIT PIN	
3	58177274	1	HOOD SEAL	
4	56174657	1	FIXING BRACKET	
5	31112150	2	SCREW TE M8X20 UNI 5739 8G	
6	31411084	3	WASHER 8,4x17	
7	56174658	1	HOOD HOOK	
8	31112151	1	SCREW TE M8X25 UNI 5739 8G	
9	56174659	1	SPACER	

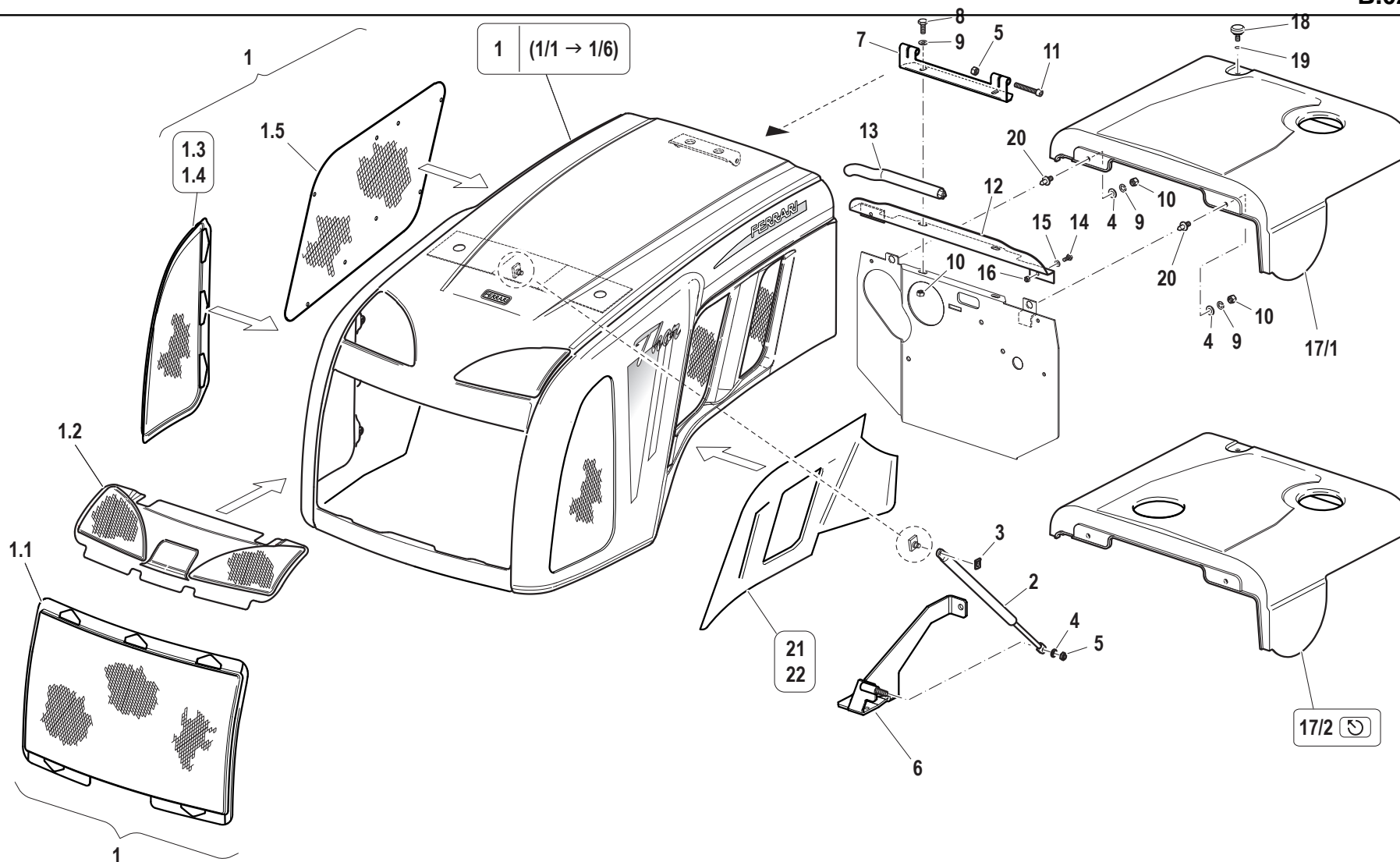

B.02.01-0

VERSIONE PRESA D'ARIA ESTERNA
EXTERNAL AIR INTAKE VERSION
VERSION PRISE D'AIR EXTÉRIEURE
AUSSENLUFTKLAPPE AUSFÜHRUNG
VERSIÓN TOMA DE AIRE EXTERNA

Pos.	Code	Q.ty	Description	Notes
1.1	56076927	1	FRONT GRILL	
1.2	56076931	1	FRONT GRILL	
1.3	56076928	1	FRONT GRILL	
1.4	56076929	1	FRONT GRILL	
1.5	56076930	1	GRILLE	
1/1	59900916	1	COMPLETE HOOD	
1/2	59900915	1	COMPLETE HOOD	
1/3	59900918	1	COMPLETE HOOD	
1/4	59900917	1	COMPLETE HOOD	
1/5	59900920	1	COMPLETE HOOD	
1/6	59900919	1	COMPLETE HOOD	
10	31211080	6	NUT M8	
11	31152088	2	SCREW TCEI M8X55 UNI 5931	
12	56174656	1	HOLDING	
13	P00000026000	1	GASKET	
14	31111091	2	SCREW E M6X14 UNI 5739 8G	
15	F0843570000	2	WASHER 6	
16	31211060	2	NUT M6	
17/1	57376670	1	COVER	
17/2	57376899	1	COVER	
18	56174835	1	KNOB	
19	35211060	1	SEEGER RING E 6 UNI 7434	
2	58092972	1	SPRING	
20	59074662	6	PIN	
21	58076984V	1	FIANCHETTO DX VERDE 75-95CV **	
22	58076987V	1	FIANCHETTO SX VERDE 75-95CV **	
3	58170436	1	CLIP	
4	31411084	6	WASHER 8,4x17	
5	F0814585000	3	SELFLOCK NUT M8	
6	59076686	1	BRACKET	
7	56179549	1	PROTECTIVE YOKE	
8	31112150	2	SCREW TE M8X20 UNI 5739 8G	
9	F0843643060	6	WASHER 8	

SERIAL

BONNET

CODE REV

B.02.01_0_47127

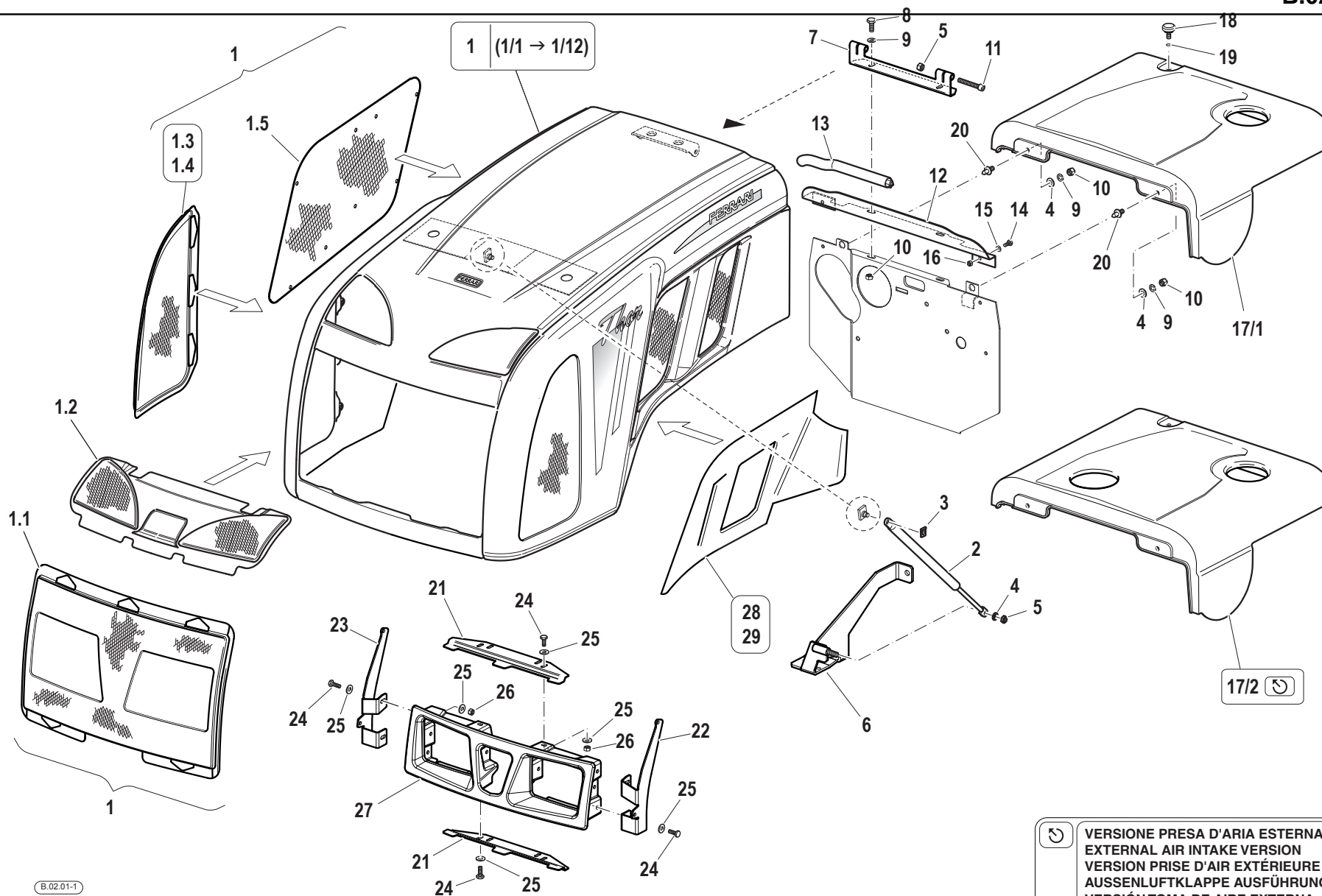

B.02.01-1

VERSIONE PRESA D'ARIA ESTERNA
EXTERNAL AIR INTAKE VERSION
VERSION PRISE D'AIR EXTÉRIEURE
AUSSENLUFTKLAPPE AUSFÜHRUNG
VERSIÓN TOMA DE AIRE EXTERNA

Pos.	Code	Q.ty	Description	Notes
1.1	56079442	1	FRONT GRILL	
1.2	56076933	1	FRONT GRILL	
1.3	56076928	1	FRONT GRILL	
1.4	56076929	1	FRONT GRILL	
1.5	56076930	1	GRILLE	
1/1	59900975	1	COMPLETE HOOD	
1/10	59900985	1	COMPLETE HOOD	
1/11	59900980	1	COMPLETE HOOD	
1/12	59900986	1	COMPLETE HOOD	
1/2	59900981	1	COMPLETE HOOD	
1/3	59900976	1	COMPLETE HOOD	
1/4	59900982	1	COMPLETE HOOD	
1/5	59900977	1	COMPLETE HOOD	
1/6	59900983	1	COMPLETE HOOD	
1/7	59900978	1	COMPLETE HOOD	
1/8	59900984	1	COMPLETE HOOD	
1/9	59900979	1	COMPLETE HOOD	
10	31211080	6	NUT M8	
11	31152088	2	SCREW TCEI M8X55 UNI 5931	
12	56174656	1	HOLDING	
13	P00000026000	1	GASKET	
14	31111091	2	SCREW E M6X14 UNI 5739 8G	
15	F0843570000	2	WASHER 6	
16	31211060	2	NUT M6	
17/1	57376670	1	COVER	
17/2	57376899	1	COVER	
18	56174835	1	KNOB	
19	35211060	1	SEEGER RING E 6 UNI 7434	
2	58092972	1	SPRING	
20	59074662	6	PIN	
21	56179447	2	SUPPORTING YOKE	
22	56179443	1	FIXING BRACKET	
23	56179444	1	BRACKET	
24	31112093	8	SCREW TE M6X20 UNI 5739 8G	

SERIAL

914901

BONNET

CODE REV

B.02.01_1_47161

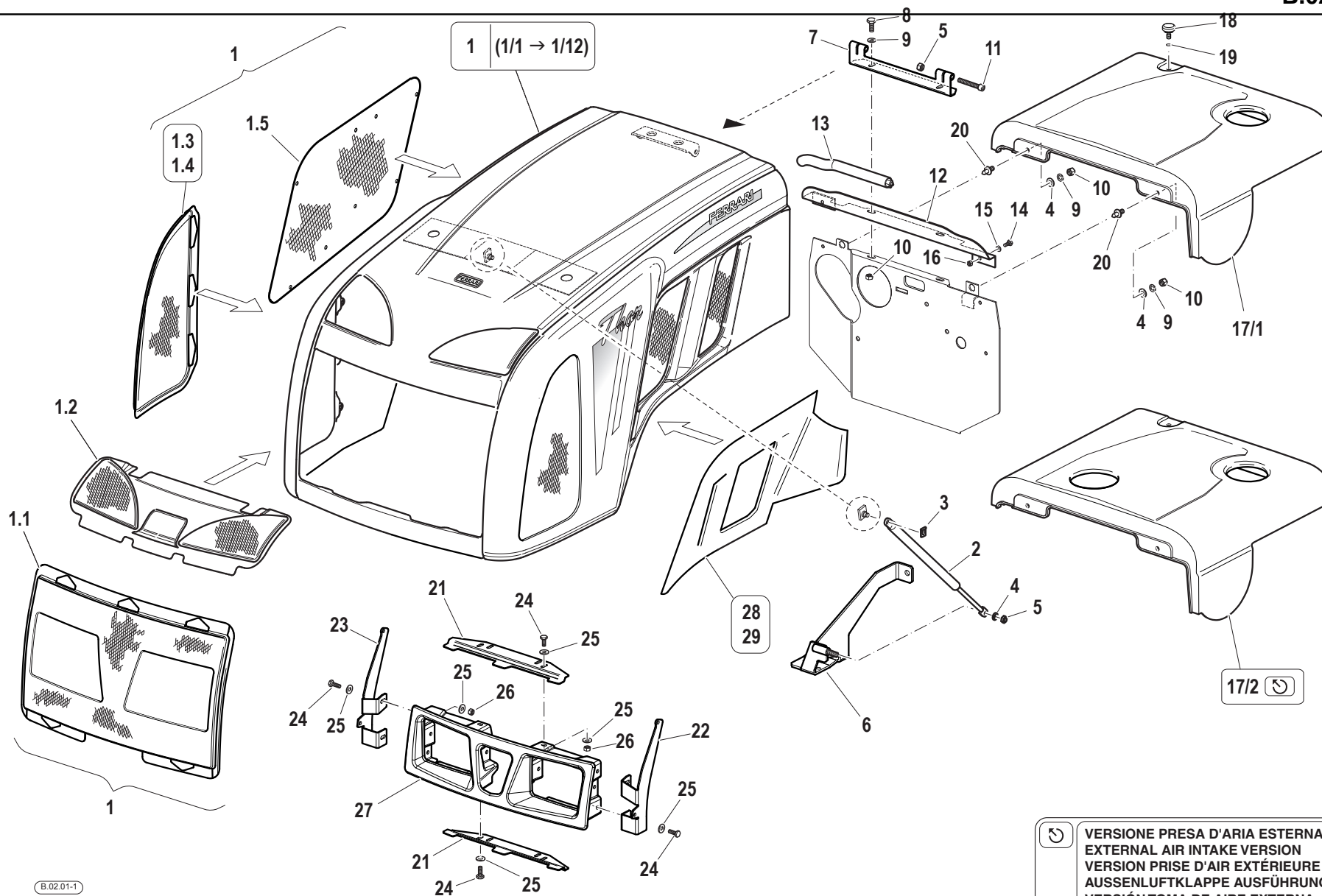

Pos.	Code	Q.ty	Description	Notes
25	31411066	16	WASHER 6,6x18	
26	F0814547000	8	SELFLOCK NUT M6	
27	57379438	1	FRONT GRILLE	
28	58076984V	1	FIANCHETTO DX VERDE 75-95CV **	
29	58076987V	1	FIANCHETTO SX VERDE 75-95CV **	
3	58170436	1	CLIP	
4	31411084	6	WASHER 8,4x17	
5	F0814585000	3	SELFLOCK NUT M8	
6	59076686	1	BRACKET	
7	56179549	1	PROTECTIVE YOKE	
8	31112150	2	SCREW TE M8X20 UNI 5739 8G	
9	F0843643060	6	WASHER 8	

FRONT MUDGUARDS

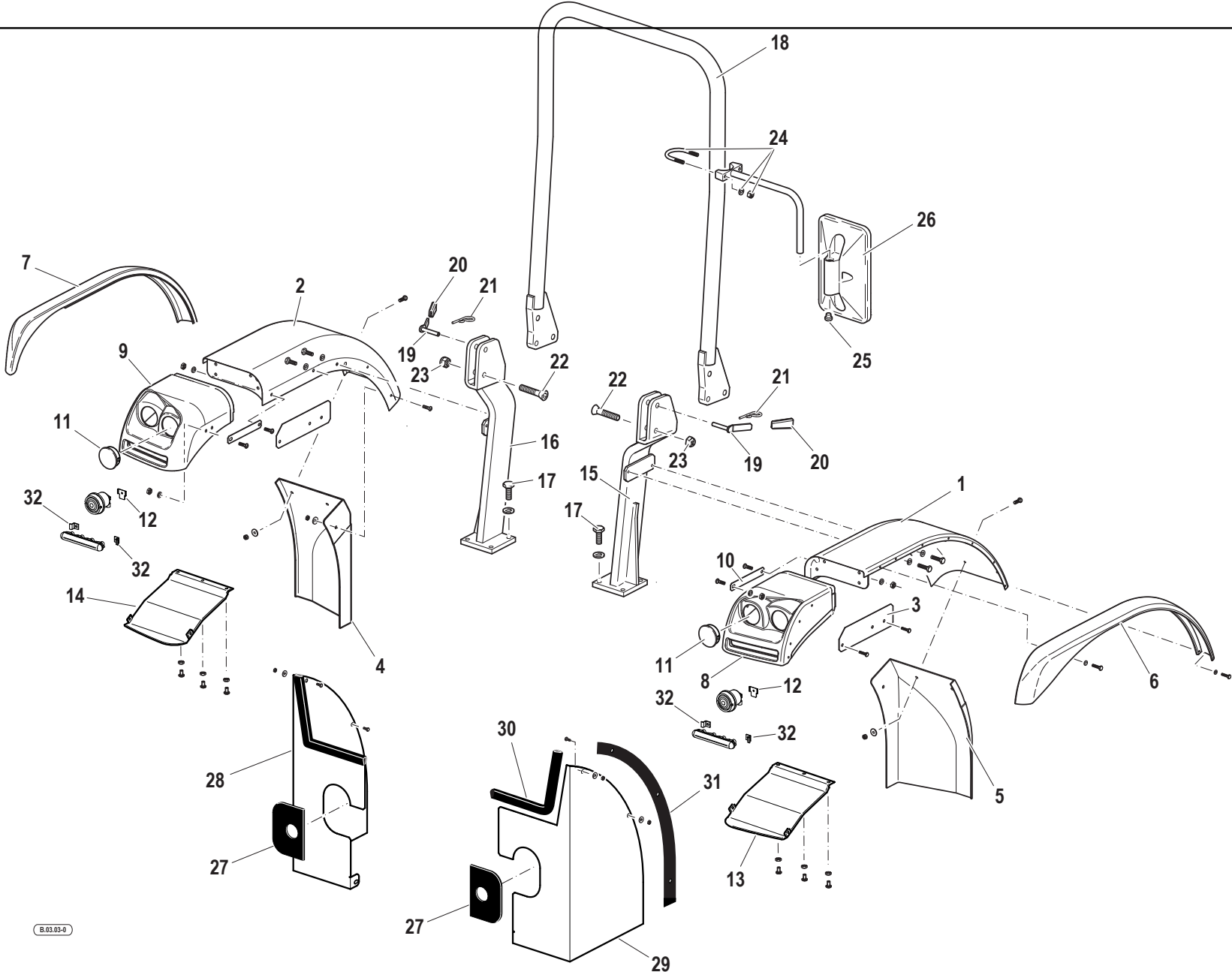

Pos.	Code	Q.ty	Description	Notes
1	59076645V	1	LEFT FRONT FENDER	
10	56177326	2	RETAINER	
11	58179414	2	PLUG	
12	56179445	1	FIXING PLATE	
13	56176906	1	COVER	
14	56176905	1	COVER	
15	59076616	1	SUPPORT	
16	59076614	1	SUPPORT	
17	31112264	8	SCREW TE M12X35 UNI 5739	
18	59076612	1	SAFETY ROLL BAR	
19	59076690	2	HINGE PIN	
2	59076641V	1	RIGHT FRONT FENDER	
20	P91728000000	2	GRIP	
21	P43914900000	2	SPLIT PIN	
22	F0864377000	2	SCREW M16X70 UNI 5737	
23	F0814794000	2	SELFLOCK NUT M16 CL.6	
24	59070591	1	SUPPORT	
25	58170968	1	PLUG	
26	30000514	1	REAR VIEW MIRROR	
27	57376900	2	SHEATH	
28	59076902	1	STRIKER PLATE	
29	59076903	1	STRIKER PLATE	
3	56177256	2	GUARD	
30	F0256808000	1	FLAT BAND	
31	F0256910000	1	FOAM PROFILE 5X20	
32	56177045	8	RETAINER	
4	57374522	1	WING EXTENSION	
5	57374523	1	WING EXTENSION	
6	57376675	1	WING EXTENSION	
7	57376676	1	WING EXTENSION	
8	57376621	1	SUPPORT	
9	57376622	1	SUPPORT	

SERIAL

FRONT MUDGUARDS

CODE REV

B.03.03_0_50588

FRONT MUDGUARDS (VERSION WITH CAB)

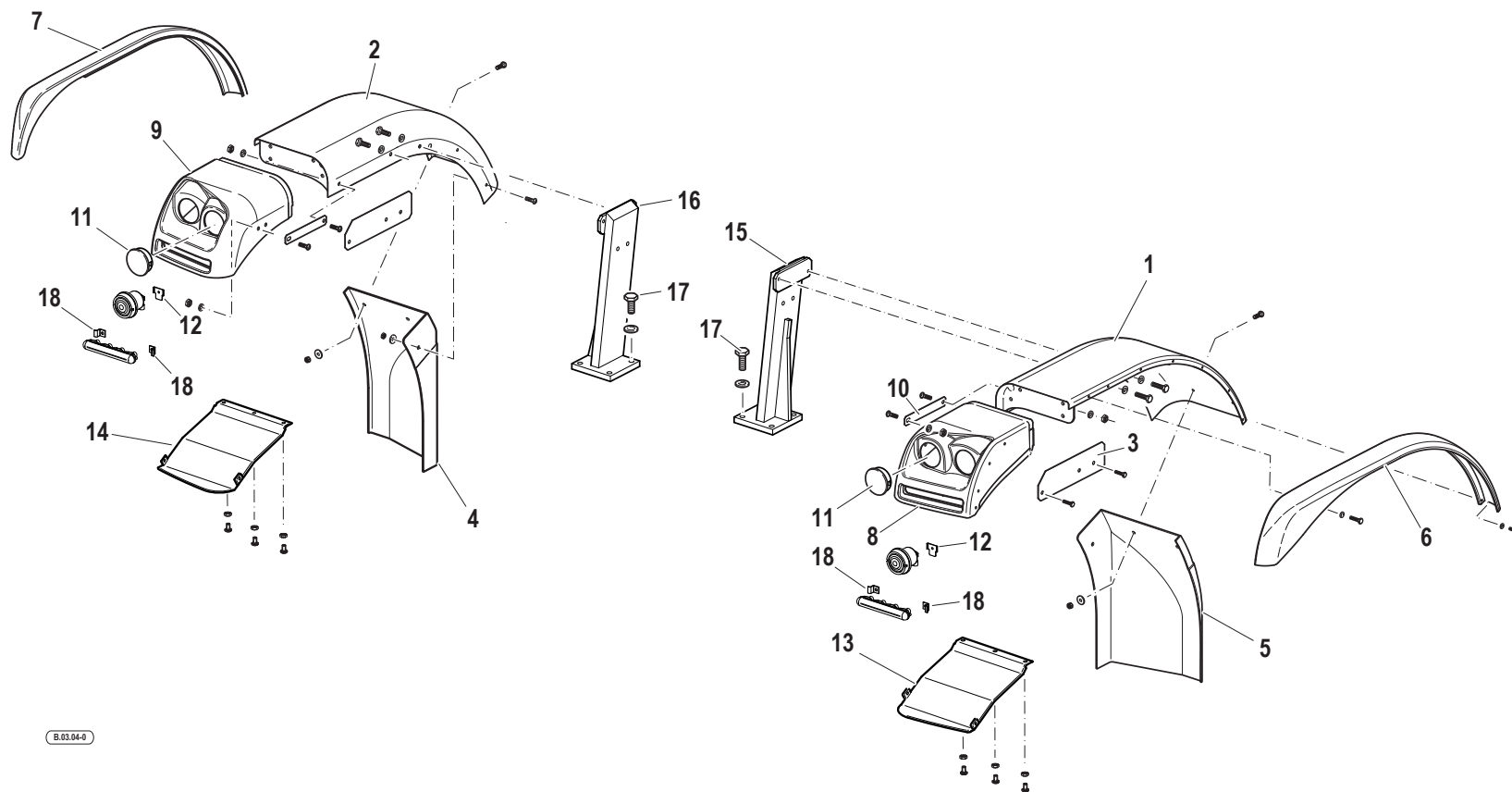

Pos.	Code	Q.ty	Description	Notes
1	59076645V	1	LEFT FRONT FENDER	
10	56177326	2	RETAINER	
11	58179414	2	PLUG	
12	56179445	1	FIXING PLATE	
13	56176906	1	COVER	
14	56176905	1	COVER	
15	59077055	1	WING HOLDER	
16	59077056	1	WING HOLDER	
17	31112264	8	SCREW TE M12X35 UNI 5739	
18	56177045	8	RETAINER	
2	59076641V	1	RIGHT FRONT FENDER	
3	56177256	2	GUARD	
4	57374522	1	WING EXTENSION	
5	57374523	1	WING EXTENSION	
6	57376675	1	WING EXTENSION	
7	57376676	1	WING EXTENSION	
8	57376621	1	SUPPORT	
9	57376622	1	SUPPORT	

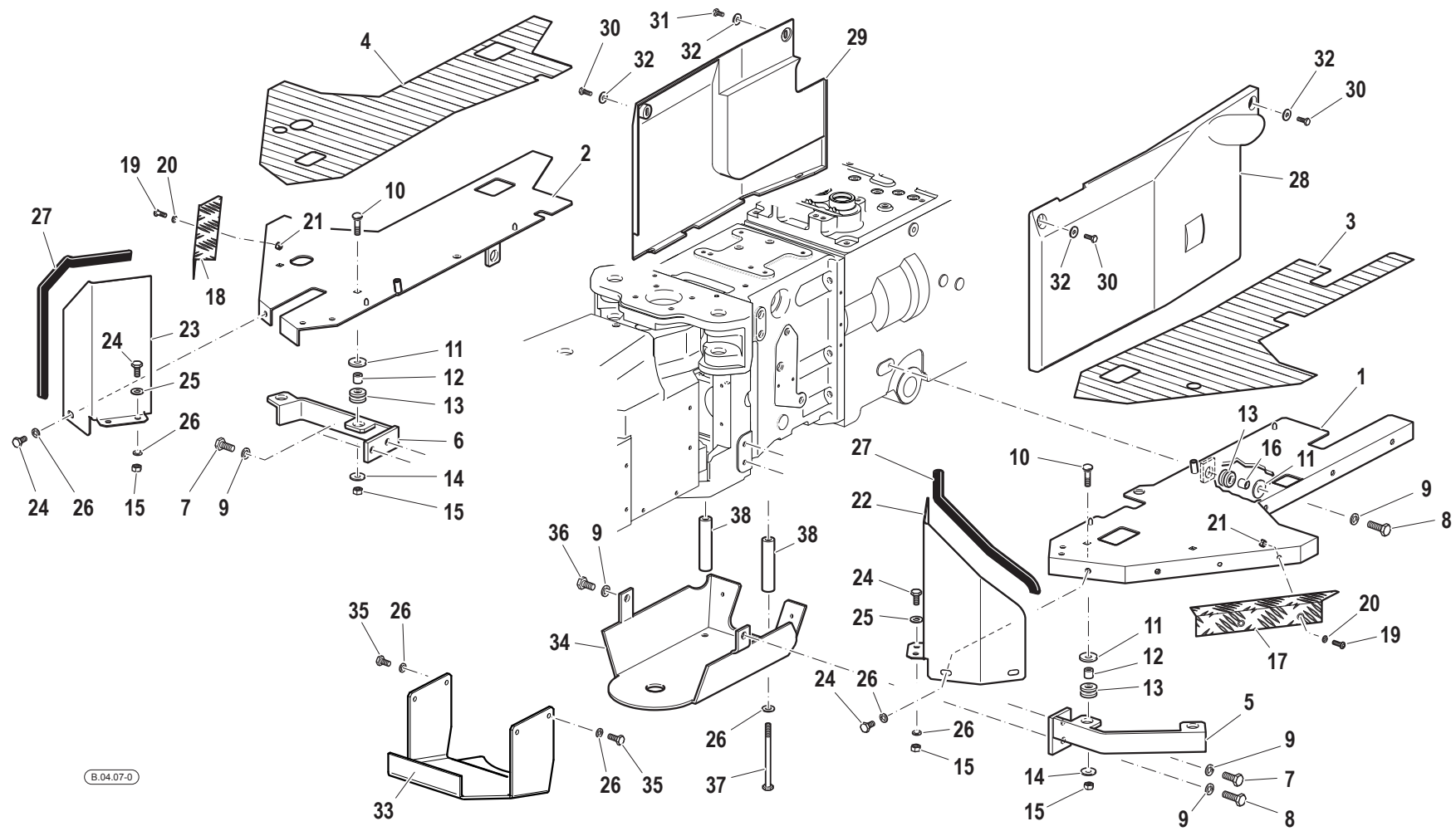

B.04.07-0

Pos.	Code	Q.ty	Description	Notes
1	59074598	1	LEFT FOOTBOARD	
10	31122804	4	SCREW TTQ M8X30 UNI 5731	
11	F0843818000	6	WASHER 11x30/2,5	
12	56171996	4	SPACER	
13	55175174	6	BLOCK	
14	31411090	4	WASHER 9x24	
15	31211080	8	NUT M8	
16	56171954	2	SPACER	
17	57275029	1	ANGULAR	
18	57275031	1	ANGULAR	
19	F0862479035	4	SCREW M6X16 7380	
2	59074599	1	RIGHT FOOTBOARD	
20	F0843570000	4	WASHER 6	
21	31211060	4	NUT M6	
22	56174667	1	FOOTBOARD PROTECTION	
23	56174666	1	FOOTBOARD PROTECTION	
24	31111151	8	SCREW TE M8X16 UNI 5739 8G	
25	31411084	4	WASHER 8,4x17	
26	F0843643060	14	WASHER 8	
27	F0256808000	1	FLAT BAND	
28	57374506	1	GUARD	
29	57374507	1	GUARD	
3	57374594	1	FOOTREST COVER	
30	F0862479035	3	SCREW M6X16 7380	
31	F0862479034	1	SCREW M6X12 7380	
32	31411066	4	WASHER 6,6x18	
33	56078831	1	SHIELD	
34	59075716	1	SHIELD	
35	31112150	4	SCREW TE M8X20 UNI 5739 8G	
36	31112210	1	SCREW TE M10X20 UNI 5739	
37	31112178	2	SCREW TE M8X130 UNI 5737	
38	56178560	2	SPACER	
4	57374595	1	FOOTREST COVER	
5	59073678	1	SUPPORT	

SERIAL

BOARDS

CODE REV

B.04.07_0_40076

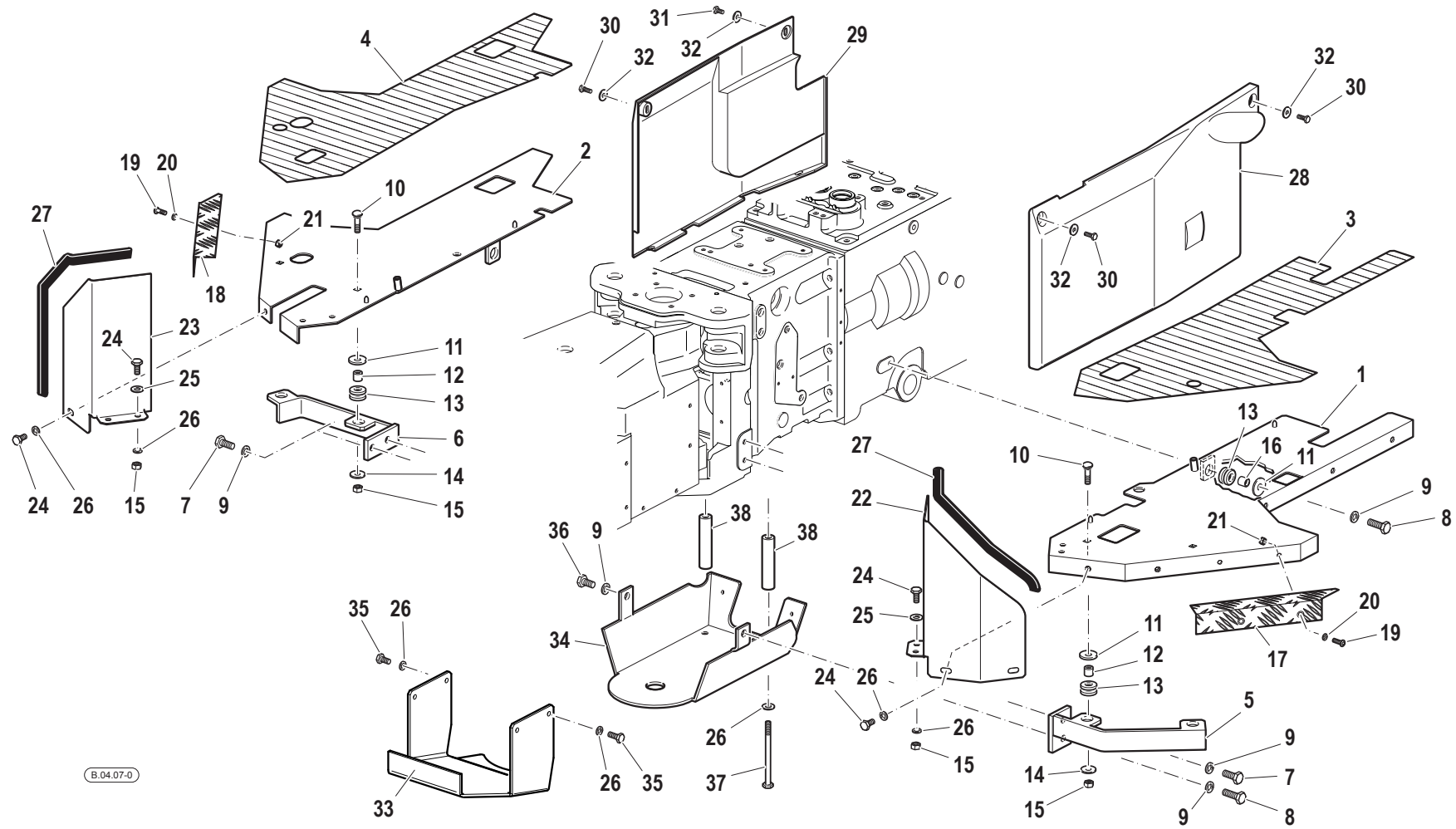

B.04.07-0

Pos.	Code	Q.ty	Description	Notes
6	59073674	1	SUPPORT	
7	31112219	3	SCREW TE M10X25 UNI 5739	
8	31112211	3	SCREW TE M10X30 UNI 5739	
9	F0843755000	7	WASHER 10	

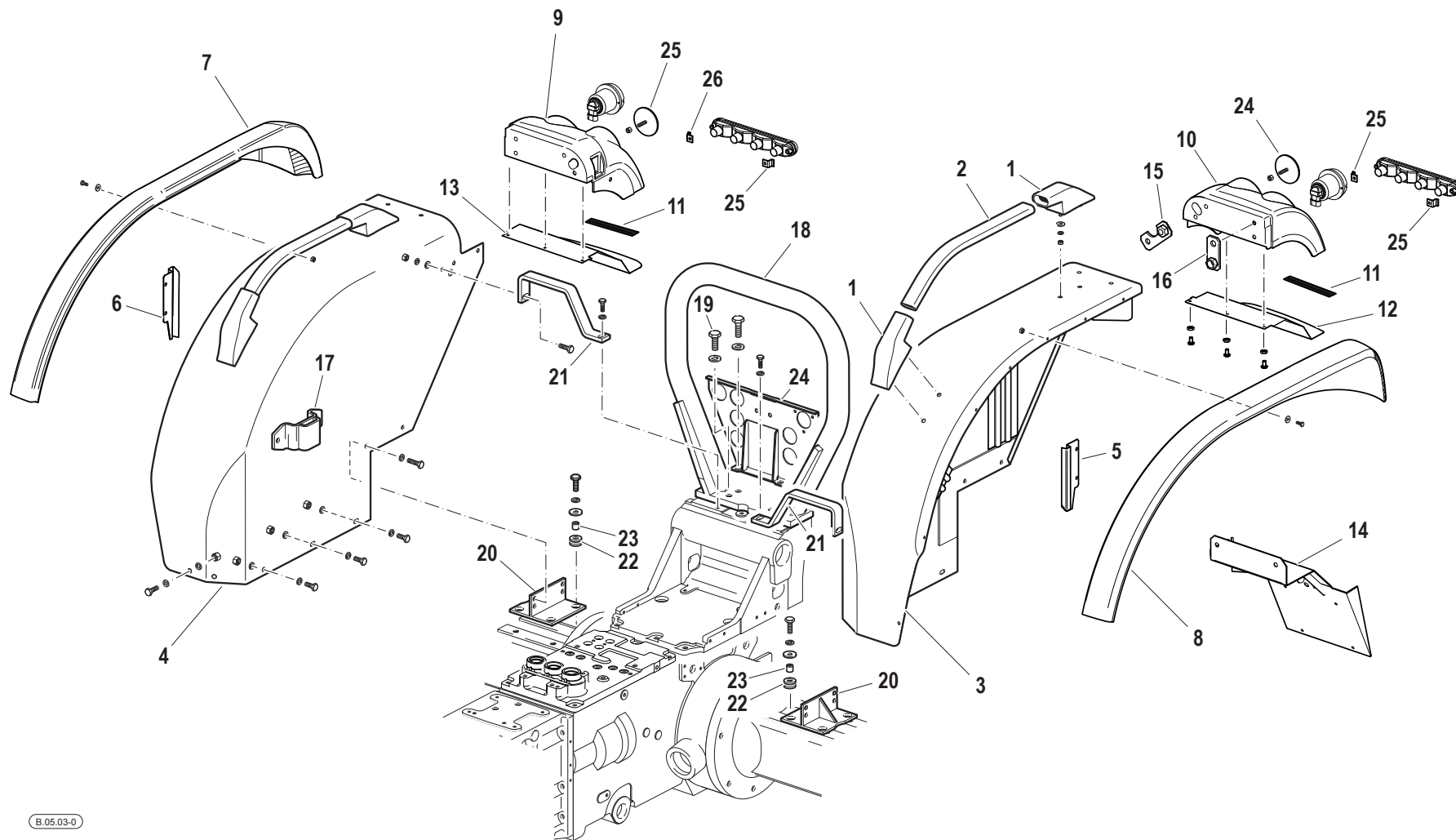

Pos.	Code	Q.ty	Description	Notes
1	55072935	4	SUPPORT	
10	57376624	1	SUPPORT	
11	F0256910010	1	CELL FOAM PROFILE 10X15	
12	56176908	1	COVER	
13	56176907	1	COVER	
14	59076780	1	LICENCE PLATE HOLD	
15	56177264	1	RETAINING PLATE	
16	56177265	1	RETAINING PLATE	
17	59070592	1	LEVER BEARING	
18	59077359	1	SAFETY ROLL BAR	
19	31112801	4	SCREW M14x1,5x40 U/5740	
2	56177252	2	MUDGUARD HANDLE	
20	59077474	2	FIXING BRACKET	
21	56177475	2	FIXING BRACKET	
22	55175174	8	BLOCK	
23	56171954	8	SPACER	
24	59071966	1	CONNECTION	
25	58177330	2	REFLECTOR	
26	56177045	8	RETAINER	
3	59077445V	1	LEFT REAR FENDER	
4	59077449V	1	RIGHT REAR FENDER	
5	56177443	1	GUARD	
6	56177444	1	GUARD	
7	57377704	1	WING EXTENSION	
8	57377707	1	WING EXTENSION	
9	57376623	1	SUPPORT	

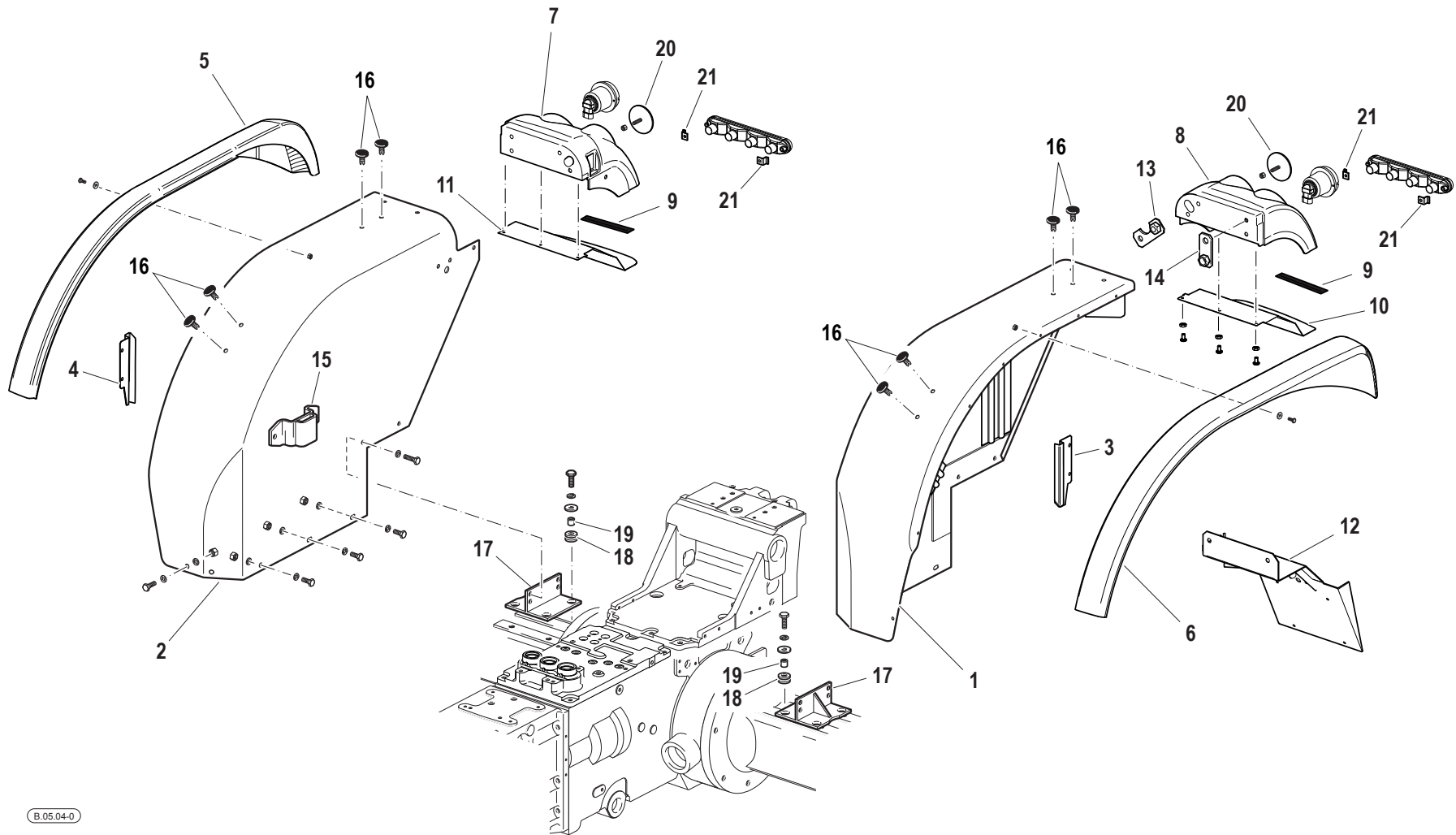
REAR MUDGUARDS (VERSION WITH CAB)

Pos.	Code	Q.ty	Description	Notes
1	59077445V	1	LEFT REAR FENDER	
10	56176908	1	COVER	
11	56176907	1	COVER	
12	59076780	1	LICENCE PLATE HOLD	
13	56177264	1	RETAINING PLATE	
14	56177265	1	RETAINING PLATE	
15	59070592	1	LEVER BEARING	
16	30040095	8	PLUG D.8,5/14	
17	59077474	2	FIXING BRACKET	
18	55175174	8	BLOCK	
19	56171954	8	SPACER	
2	59077449V	1	RIGHT REAR FENDER	
20	58177330	2	REFLECTOR	
21	56177045	8	RETAINER	
3	56177443	1	GUARD	
4	56177444	1	GUARD	
5	57377704	1	WING EXTENSION	
6	57377707	1	WING EXTENSION	
7	57376623	1	SUPPORT	
8	57376624	1	SUPPORT	
9	F0256910010	1	CELL FOAM PROFILE 10X15	

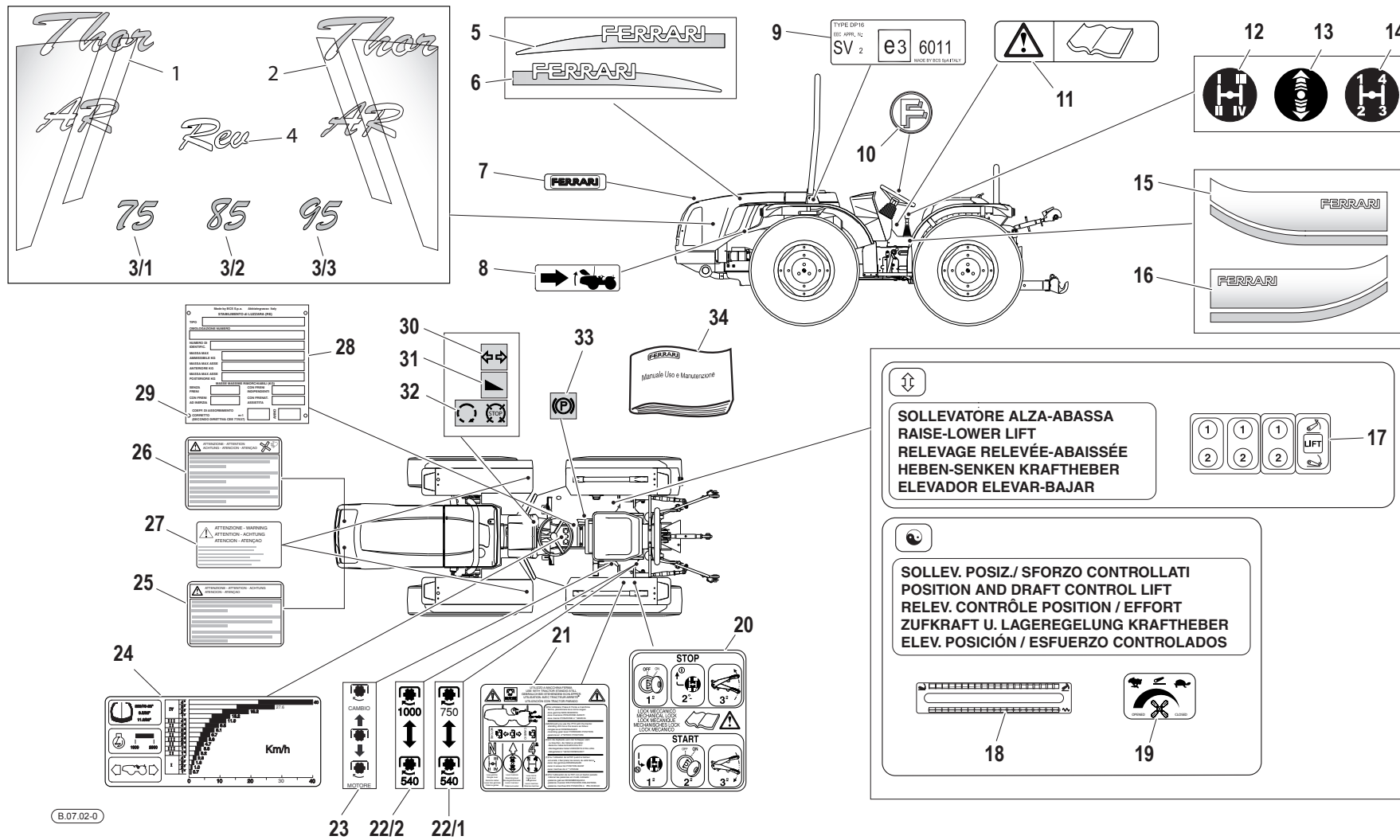

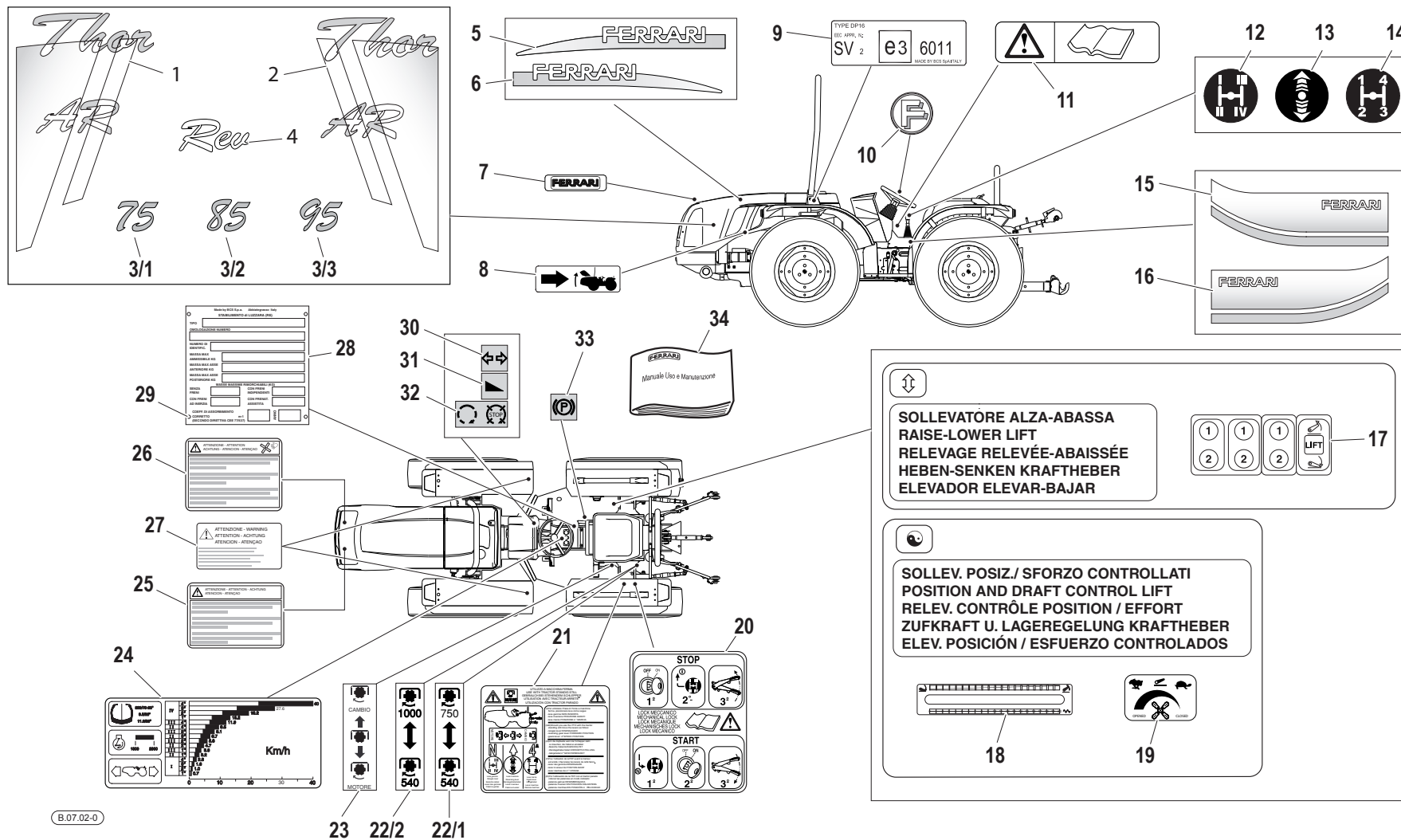

Pos.	Code	Q.ty	Description	Notes
1	58074792	1	DECAL THOR LH	
10	58074777	1	DECAL	
11	58074880	1	PLATE	
12	58074221	1	DECAL	
13	58074220	1	DECAL	
14	58074222	1	DECAL	
15	58074839	1	DECAL	
16	58074846	1	DECAL	
17	58075022	1	PLATE	
18	58075153	1	DECAL	
19	58075250	1	DECAL	
2	58074793	1	DECAL THOR RH	
20	58075021	1	DECAL	
21	58076077	1	DECAL	
22/1	58072518	1	PLATE	
22/2	58072574	1	PLATE	
23	58072575	1	PLATE	
24	58077654	1	PLATE	
25	58173772	1	PLATE	
26	58173773	1	PLATE	
27	58073156	2	PLATE	
28	58072737	1	PLATE	
29	F0808518050	4	RIVET 3,5x6,5	
3/1	58077581	2	DECAL 75 RH-LH	
3/2	58077580	2	DECAL 85 RH-LH	
3/3	58077579	2	DECAL 95 RH-LH	
30	58072509	1	INSTRUCTION PLATE	
31	58072517	1	INSTRUCTION PLATE	
32	58072511	1	INSTRUCTION PLATE	
33	58072510	1	INSTRUCTION PLATE	
34	F0907170150	1	TECHN. MANUAL THOR	
4	58074791	2	DECAL	
5	58074786	1	DECAL	
6	58074787	1	DECAL	

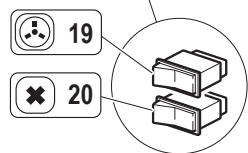
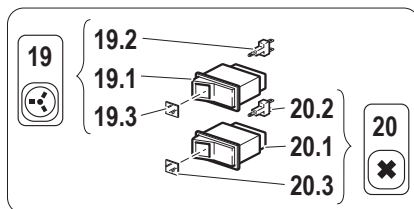
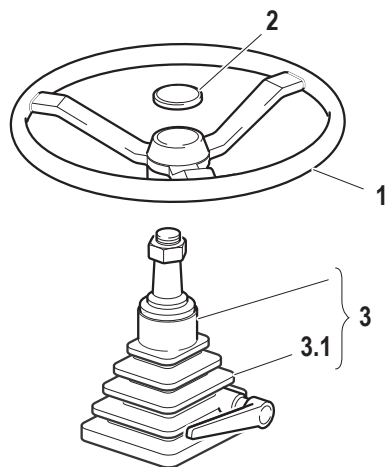

Pos.	Code	Q.ty	Description	Notes
7	58079466	1	DECAL	
8	58074841	1	DECAL	
9	58077615	1	PLATE	



 **PRESA DI FORZA CON FRIZIONE INDIPENDENTE**
POWER TAKE-OFF WITH INDEPENDENT CLUTCH
PRISE DE FORCE AVEC EMBRAYAGE INDEPEND.
ZAPFWELLE MIT UNABHÄNGIGER KUPPLUNG
TOMA DE FUERZA CON EMBRAGUE INDEPEND.

 **DIFFERENZIALE CON BLOCCAGGIO ELETTROIDRAUL.**
DIFFERENTIAL WITH ELECTROHYDRAULIC LOCKING
DIFFERENTIEL AVEC BLOCAGE ÉLECTROHYDR.
DIFFERENTIAL MIT ELEKTROHYDR. SPERRE
DIFERENCIAL CON BLOQUEO ELECTROHIDRÁULICO

 **QUADRO STRUMENTAZIONE DIGITALE**
DIGITAL INSTRUMENT DISPLAY
TABLEAU DE L'INSTRUMENTATION DIGITALE
DIGITALES GERÄT TAFEL
CUADRANTE DE LA INSTRUMENTACIÓN DIGITAL

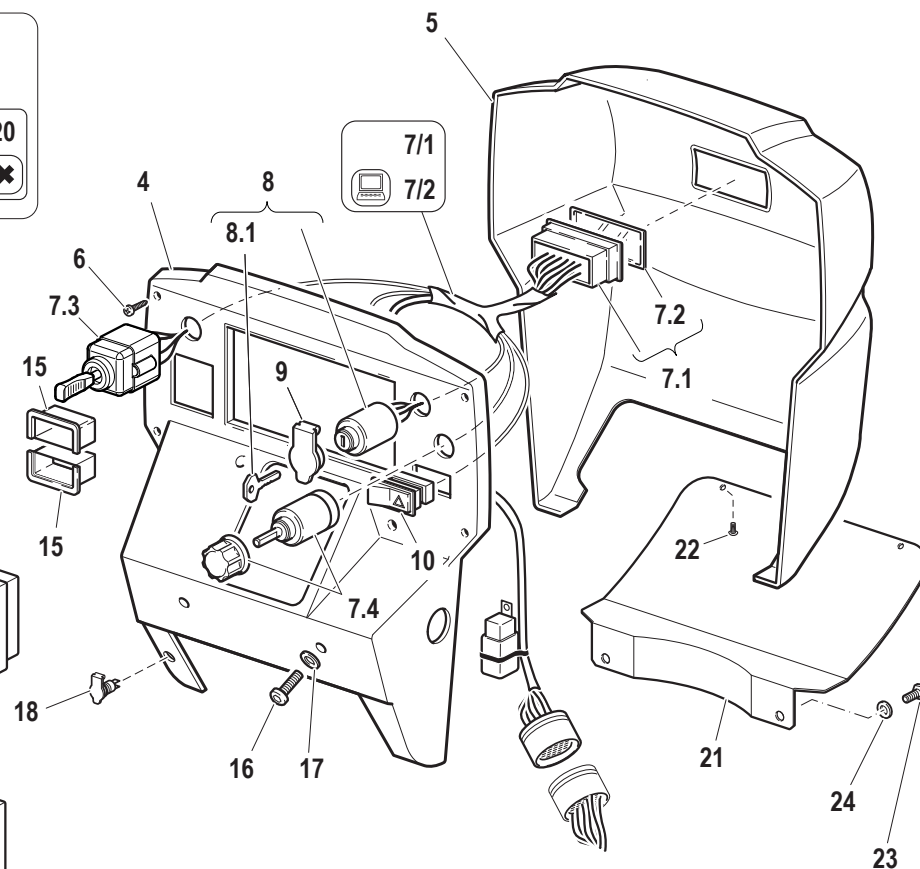
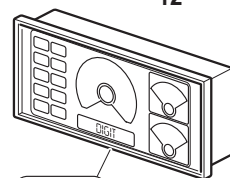
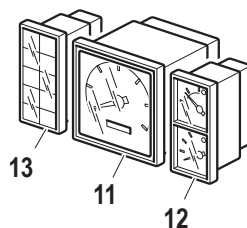

Pos.	Code	Q.ty	Description	Notes
1	F0865040000	1	STEERING WHEEL	
10	F0825115010	1	PUSH-BUTTON	
11	58177867	1	TRACTOR METER	
12	58175769	1	DIGITAL INSTRUMENT	
13	58175770	1	WARNING LIGHT HOLDER	
14	58174928	1	INSTRUMENT	
15	58170376	2	TERMINAL FOR SWITCH	
16	F0862479020	4	SCREW M8X16 7380	
17	31411084	4	WASHER 8,4x17	
18	F0825403050	1	SOCKET	
19	58170344	1	CHANGE-OVER SWITCH	
19.1	58173116	2	CHANGE-OVER SWITCH	
19.2	58173119	2	LAMP	
19.3	58173120	1	GLASS	
2	F0865040020	1	PLUG	
20	58170345	1	CHANGE-OVER SWITCH	
20.1	58173116	2	CHANGE-OVER SWITCH	
20.2	58173119	2	LAMP	
20.3	58173121	1	GLASS	
21	57374553	1	COVER	
22	F0861867001	3	SCREW M4,2X16 DIN 7981	
23	31112149	2	SCREW TE M8X12 UNI 5739 8G	
24	31411084	2	WASHER 8,4x17	
3	F0865474000	1	UNIT	
3.1	F0865474005	1	BELLOWS	
4	55274441	1	INSTRUMENT PANEL	
5	55271644	1	INSTRUMENT PANEL	
6	31510053	6	RIBBED SCREW TC 4,8X32	
7.1	58170453	1	FUSE BOX	
7.2	58172267	1	COVER	
7.3	F0825436000	1	SWITCH	
7.4	F0825436003	1	SWITCH	
7/1	58077601	1	CABLE	
7/2	58077602	1	CABLE	

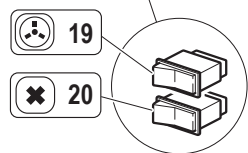
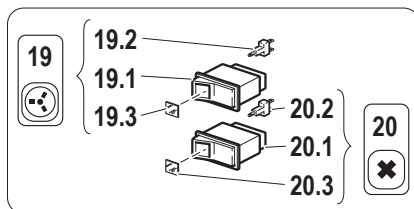
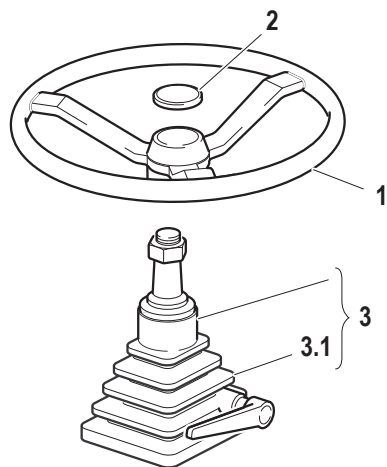

 **PRESA DI FORZA CON FRIZIONE INDIPENDENTE**
POWER TAKE-OFF WITH INDEPENDENT CLUTCH
PRISE DE FORCE AVEC EMBRAYAGE INDEPEND.
ZAPFWELLE MIT UNABHÄNGIGER KUPPLUNG
TOMA DE FUERZA CON EMBRAGUE INDEPEND.

 **DIFFERENZIALE CON BLOCCAGGIO ELETTROIDRAUL.**
DIFFERENTIAL WITH ELECTROHYDRAULIC LOCKING
DIFFERENTIEL AVEC BLOCAGE ÉLECTROHYDR.
DIFFERENTIAL MIT ELEKTROHYDR. SPERRE
DIFERENCIAL CON BLOQUEO ELECTROHIDRÁULICO

 **QUADRO STRUMENTAZIONE DIGITALE**
DIGITAL INSTRUMENT DISPLAY
TABLEAU DE L'INSTRUMENTATION DIGITALE
DIGITALES GERÄT TAFEL
CUADRANTE DE LA INSTRUMENTACIÓN DIGITAL

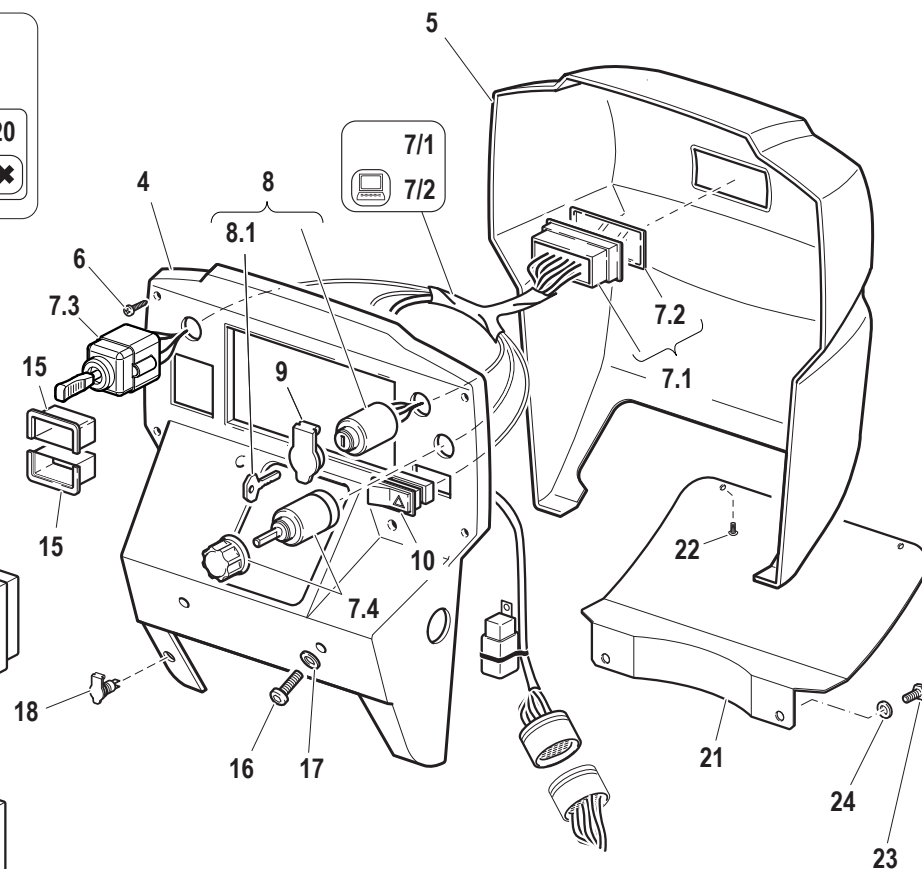
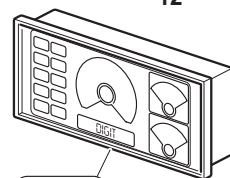
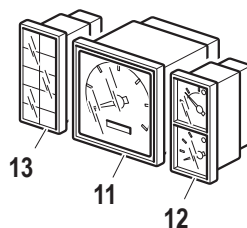

Pos.	Code	Q.ty	Description	Notes
8	30000614	1	PANEL	
8.1	F0825500220	1	KEY	
9	F0825400060	1	COVER	

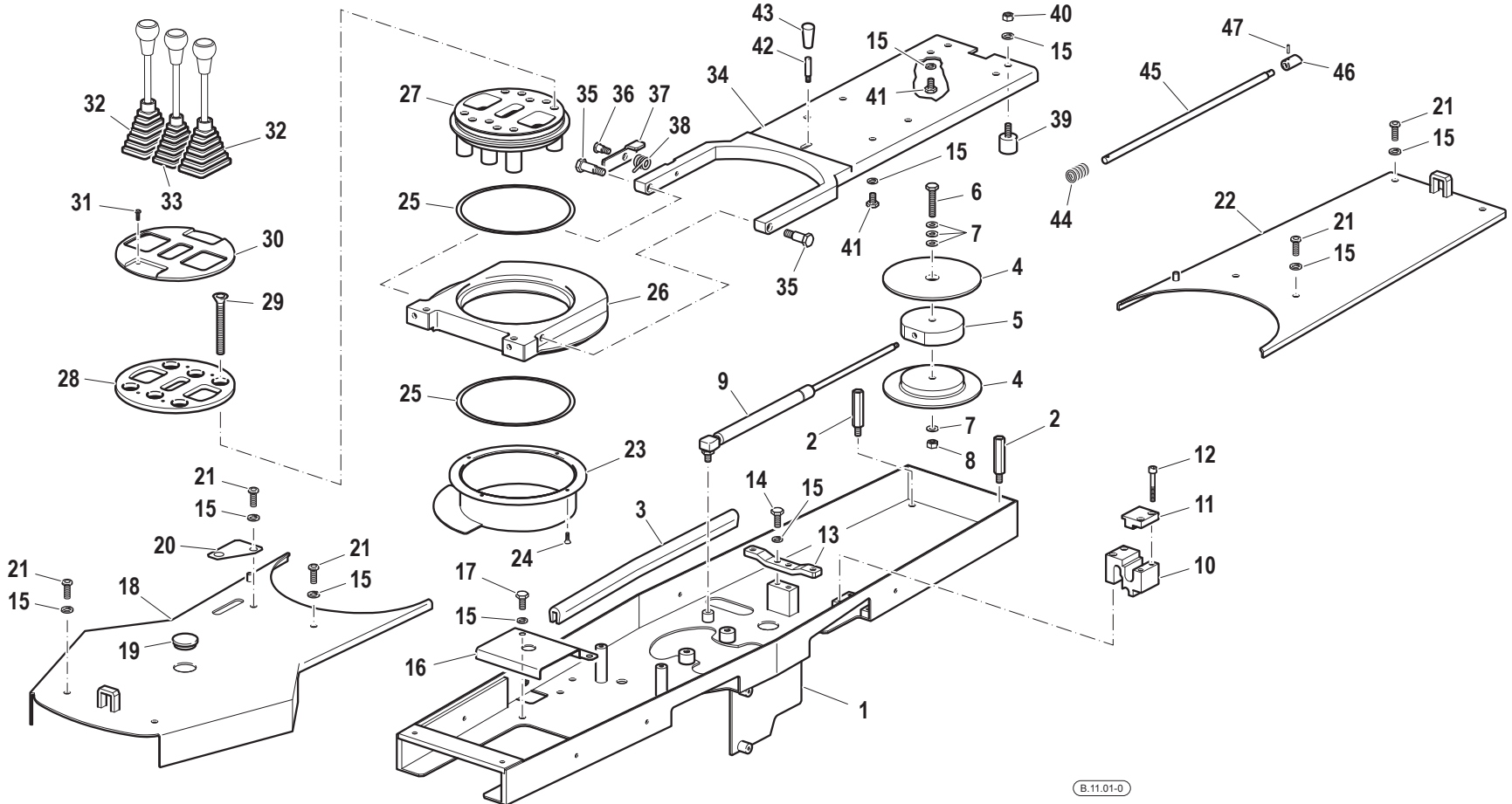

Pos.	Code	Q.ty	Description	Notes
1	59074468	1	BOX	
10	56174464	1	SMALL BLOCK	
11	56174773	1	COVER	
12	31152066	4	SCREW TCEI M6X45 UNI 5931	
13	56174486	1	RETAINER	
14	31112146	2	SCREW TE M8X22 UNI 5739 8G	
15	F0843643060	16	WASHER 8	
16	56174489	1	PLATE	
17	31112147	2	SCREW TE M8X18 UNI 5739 8G	
18	59074476V	1	COP.ANT.SC.TUB(59074476)VERDE	
19	F0852516020	1	CABLE GLAND D.32	
2	56174492	2	PIN	
20	56174499	1	COVER	
21	59074477V	1	COP.POST.C.TUBI(74477)VERDE	
21	F0862479020	8	SCREW M8X16 7380	
23	59074403	1	FLANGE	
24	31132440	4	SCREW TSVEI M4X10 UNI 5933	
25	57374545	2	GASKET	
26	51174524V	1	TORRETTA GIREV.(74524)VERDE	
27	51274388	1	SUPPORT	
28	51274498	1	FLANGE	
29	F0863586000	6	SCREW M10X80 DIN 7991	
3	F0256809010	1	GASKET	
30	57374501	1	COVER	
31	F0861928050	4	SCREW M5X12 ISO 7380	
32	55174163	2	BELLOWS	
33	55174162	1	BELLOWS	
34	59074525V	1	SUPP.SEDILE(59074525F)VERDE	
35	56274487	2	SPECIAL SCREW	
36	56375436	1	HINGE PIN	
37	56174462	1	RETAINING PLATE	
38	58074488	1	SPRING	
39	58174644	2	SILENT-BLOCK	
4	57374490	2	PULLEY	

SERIAL

SEAT SUPPORT / GEAR LEVERS COVER

CODE REV

B.11.01_0_38871

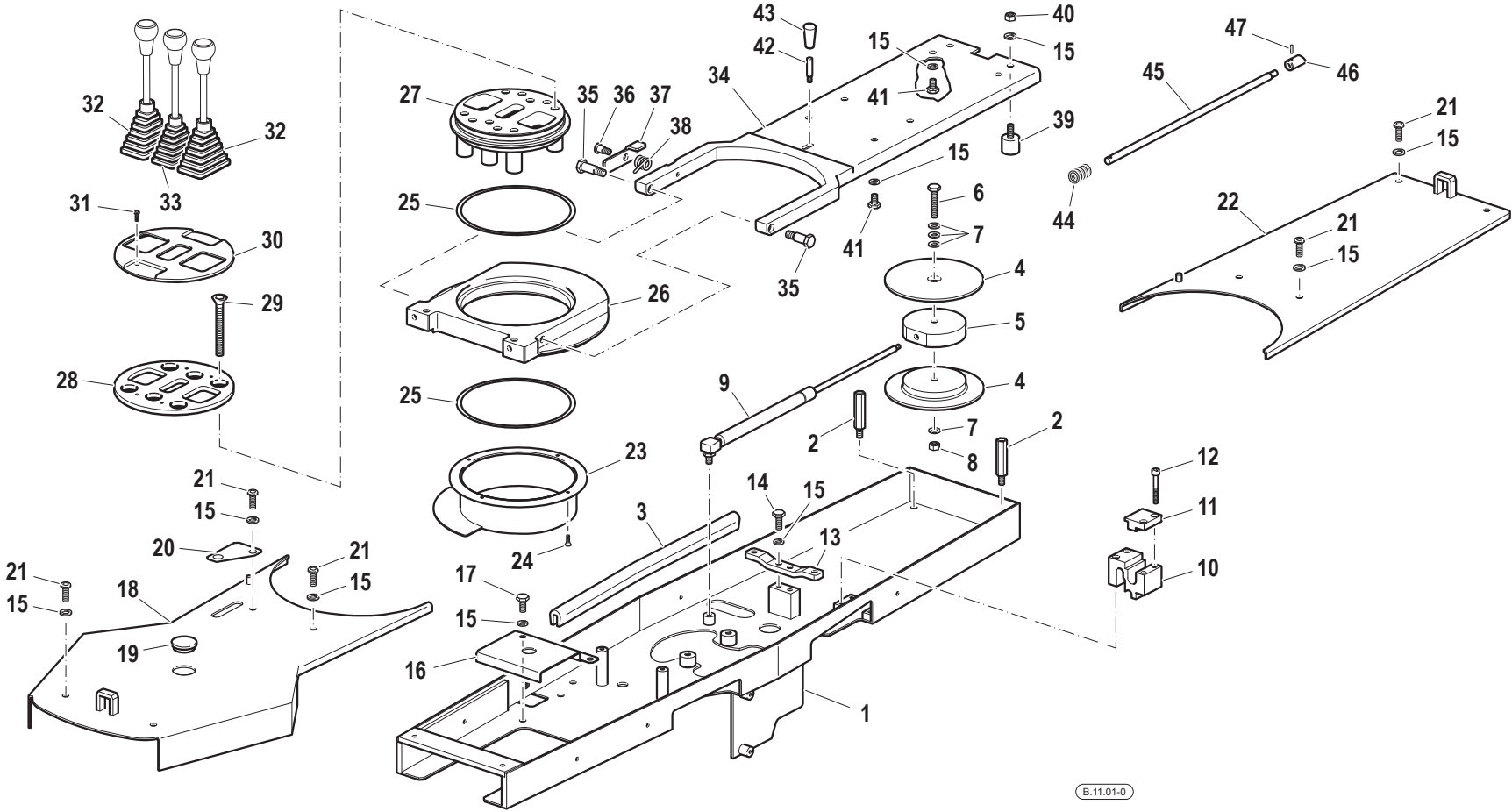

Pos.	Code	Q.ty	Description	Notes
40	31211080	2	NUT M8	
41	31111151	4	SCREW TE M8X16 UNI 5739 8G	
42	56174461	1	PIN	
43	F0837521000	1	GRIP	
44	58070390	1	SEAT SPRINGS	
45	56174463	1	ROD	
46	56374460	1	LOCKING BOLT	
47	34213018	1	ROLL PIN	
5	57374491	1	PULLEY	
6	F0862875000	1	SCREW M8X1,25/45 UNI5739	
7	31411084	4	WASHER 8,4x17	
8	F0814585000	1	SELFLOCK NUT M8	
9	58174555	1	SPRING	

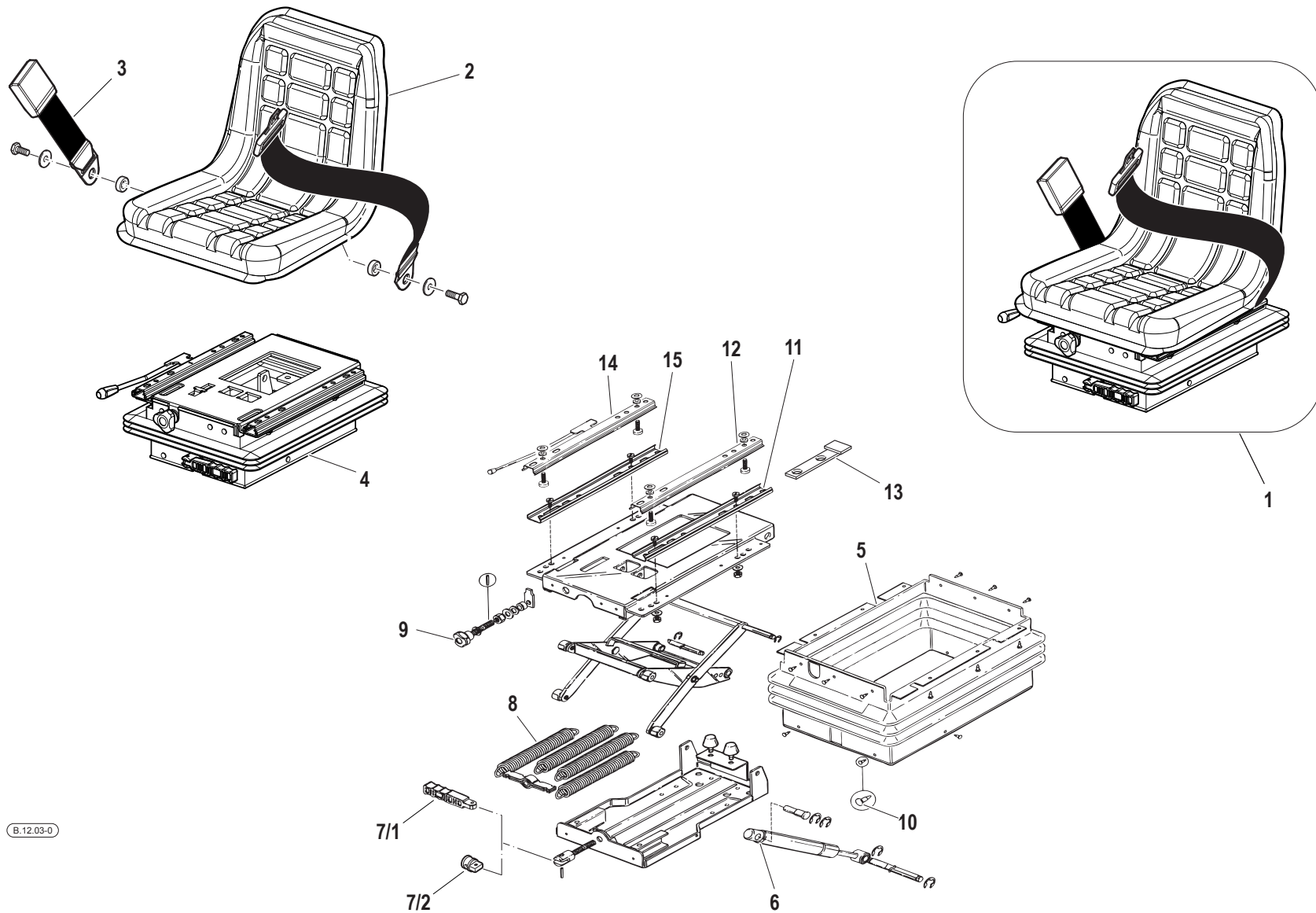

Pos.	Code	Q.ty	Description	Notes
1	58177722	1	SEAT	
10	59900157	1	LOWER GUIDE	
10	59900158	18	SCREW	
12	59900160	1	GUIDE	
13	59071241	1	STOP PLATE	
14	59900161	1	GUIDE	
15	59900152	1	LOWER GUIDE	
2	59901050	1	SEAT	
3	58192377	1	SAFETY BELT	
4	59901049	1	SUSPENSION	
5	59900159	1	BELLOWS	
6	59900156	1	SHOCKS ABSORBER	
7/1	59900155	1	LEVER	
7/2	56172172	1	SMALL BLOCK	
8	59900154	4	SPRING	
9	59900153	1	KNOB	

◆
 VERSIONE CON CABINA
 VERSION WITH CAB
 VERSION AVEC LA CABINE
 VERSION MIT KABINE
 VERSIÓN CON LA CABINA

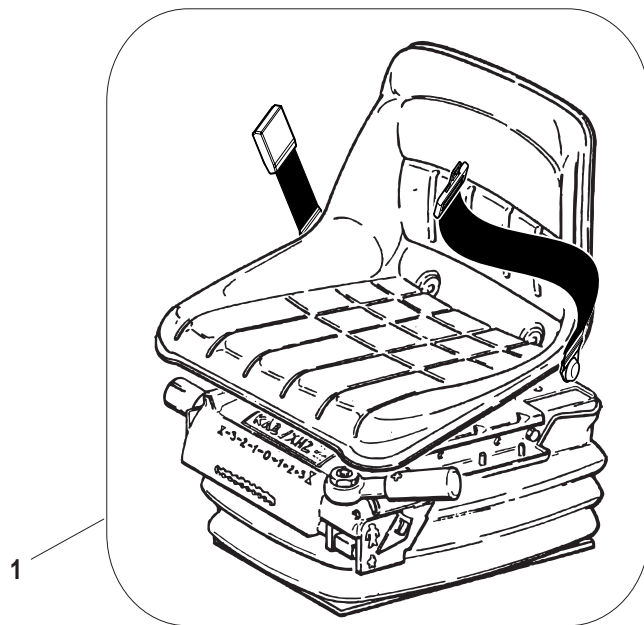

B.12.02-0

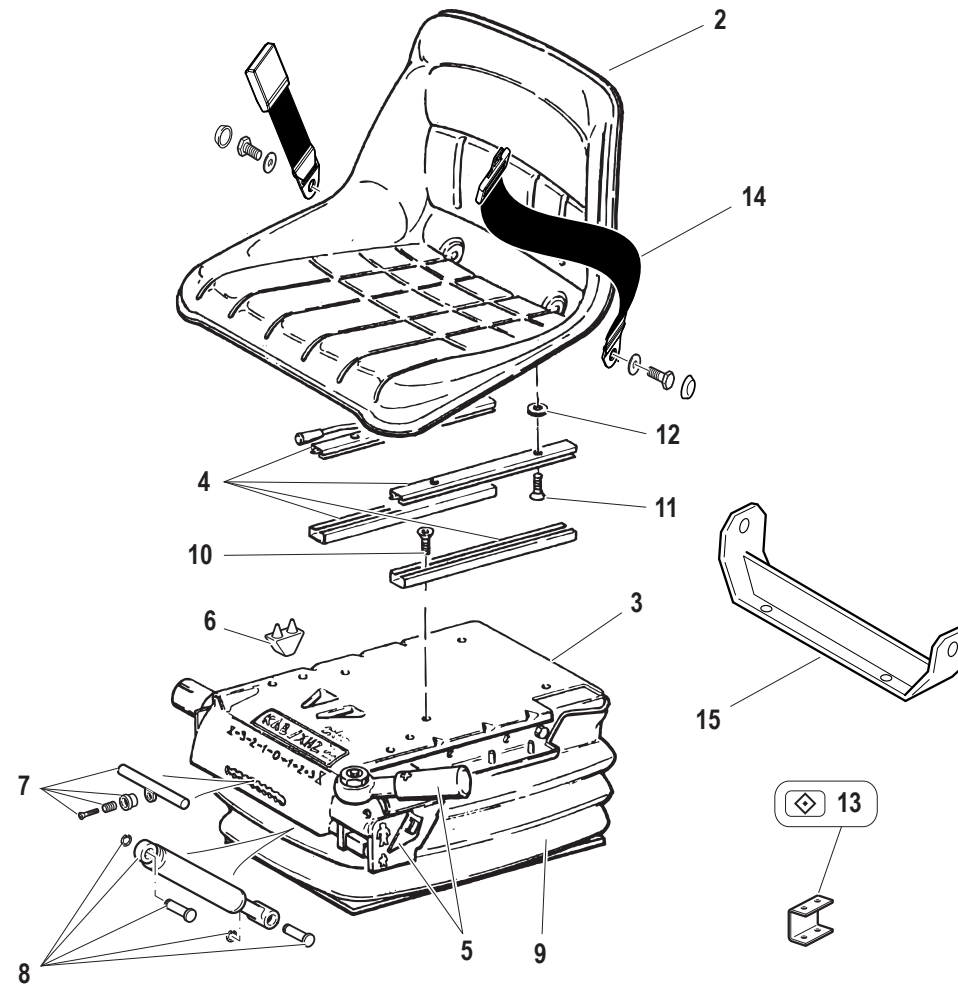

◆ 13

Pos.	Code	Q.ty	Description	Notes
1	59900199	1	SEAT	
10	31111151	5	SCREW TE M8X16 UNI 5739 8G	
11	F0862495010	4	SCREW M8X16 UNI 5931	
12	F0843696000	6	WASHER D.24x8/6	
13	56171223	1	BRACKET	
14	58192377	1	SAFETY BELT	
15	56178591	1	BRACKET	
2	F0150036216	1	SEAT CAVITY	
3	F0150036219	1	SPRING	
4	58173437	1	SEAT GUIDE	
5	59900183	1	CONTROL	
6	59900184	1	SPRINGS LIMITER	
7	59900185	1	CONTROL	
8	59900186	1	SHOCKS ABSORBER	
9	59900187	1	BELLOWS	

QUADRO STRUMENTAZIONE DIGITALE
DIGITAL INSTRUMENT DISPLAY
TABLEAU DE L'INSTRUMENTATION DIGITALE
DIGITALES GERÄT TAFEL
CUADRANTE DE LA INSTRUMENTACIÓN DIGITAL

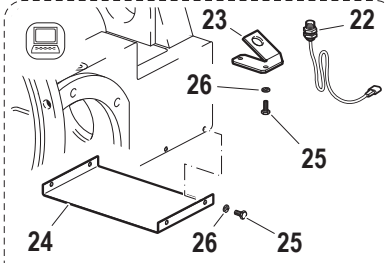

VEDI ANCHE ...
SEE ALSO ...
VOIR AUSSI ...
SIEHE AUCH ...
VER TAMBIEN ...

D.01.02

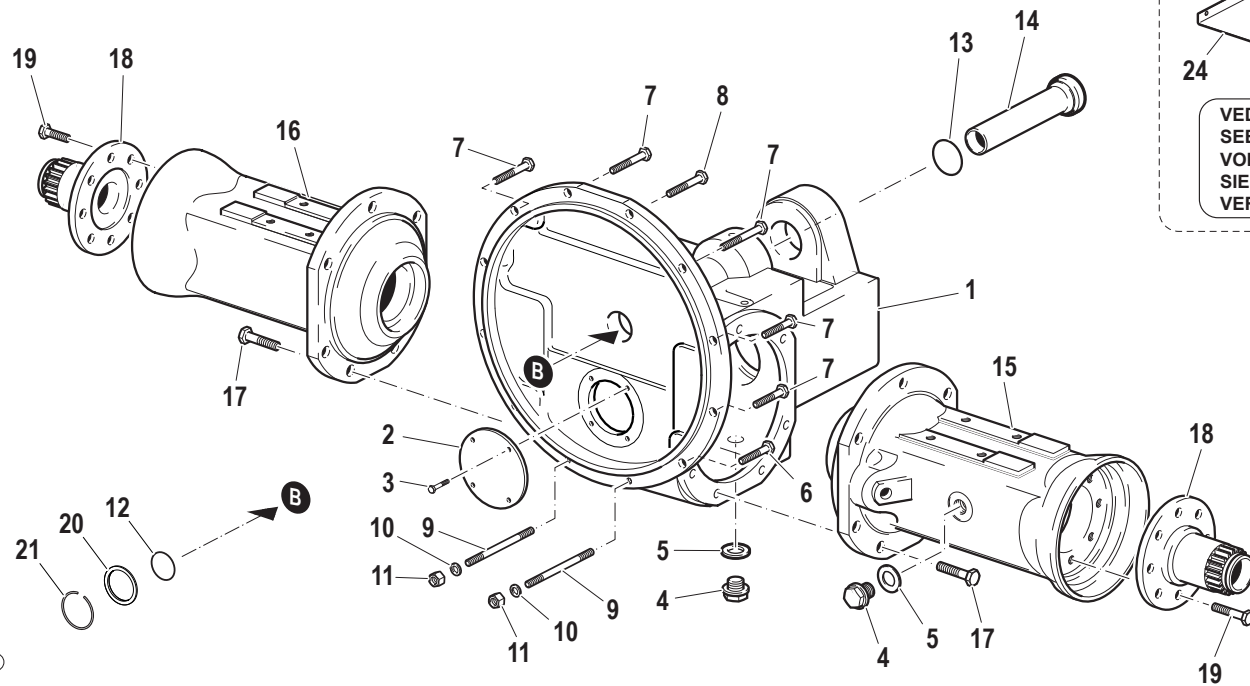

Pos.	Code	Q.ty	Description	Notes
1	51176126	1	FRONT AXLE HOUSING	
10	F0814632000	2	NUT M10	
11	F0843755000	12	WASHER 10	
12	F0803259000	1	O-RING 144 (39,69x3,53)	
13	F0803209070	1	O-RING 3187	
14	59070012	1	PIPE	
15	51173806	1	FRONT AXLE HOUSING	
16	51173805	1	FRONT AXLE HOUSING	
17	F0864222010	16	SCREW M14X1,5/40 5738	
18	56373800	2	SUPPORT	
19	F0863890010	16	SCREW M12x1,75x35	
2	51176125	1	FRONT COVER	
20	56177068	1	SPACER	
21	F0801310600	1	SAFETY RING	
22	58175209	1	SENSOR	
23	56174919	1	BRACKET	
24	56172538	1	LAMINATION	
25	31112082	8	SCREW TE M6X12 UNI 5739 8G	
26	F0843570000	8	WASHER 6	
3	31112090	4	SCREW TE M6X16 UNI 5739 8G	
4	56370081	2	PLUG	
5	F0844273090	2	GASKET 22X28X1,5 CU 99,5	
6	31112211	2	SCREW TE M10X30 UNI 5739	
7	31112212	7	SCREW TE M10X35 UNI 5739	
8	31112213	1	SCREW TE M10X40 UNI 5739	
9	F0838475000	2	STUD BOLT M10X90 UNI 5911 8.8	

SERIAL

FRONT AXLE

CODE REV

C.01.02_0_39031

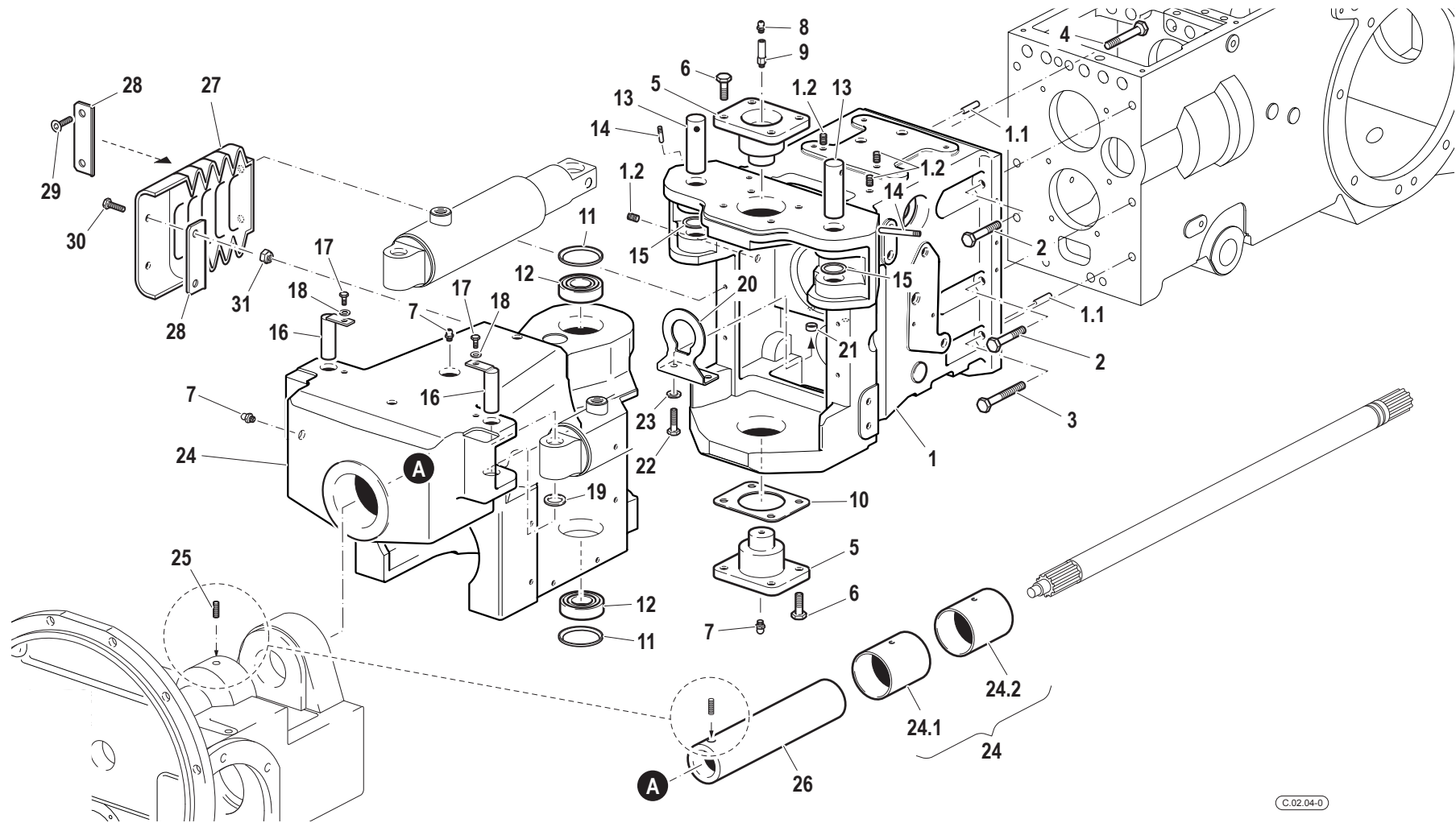

Pos.	Code	Q.ty	Description	Notes
1	59276003	1	BOX	
1.1	56570016	2	CYLINDRICAL PLUG	
1.2	58079118	1	ROD	
10	52173669	1	SHIM	
10	52173670	1	SHIM	
10	52173671	1	SHIM	
10	52173672	1	SHIM	
10	52173673	1	SHIM	
11	58170077	2	GASKET	
12	F0812838000	2	BEARING 32007 (35x62x18 R)	
13	56374556	2	HINGE PIN	
14	56370178	2	SCREW	
15	56374557	2	SPACER	
16	59070838	2	HINGE PIN	
17	31111151	2	SCREW TE M8X16 UNI 5739 8G	
18	F0843643060	2	WASHER 8	
19	F0844240000	2	WASHER 20,5x33/3	
2	F0863925000	7	SCREW M12X40 UNI 5737	
20	59075813	1	BRACKET	
21	56170364	2	SPACER	
22	31112146	2	SCREW TE M8X22 UNI 5739 8G	
23	F0843643060	2	WASHER 8	
24	59276002	1	BOX	
25	56276372	1	BUSHING	
25.1	56276371	1	BUSHING	
25.2	58077226	1	GRAIN	
26	56477227	1	PIN	
27	55174429	2	BELLOWS	
28	56174446	4	FIXING BRACKET	
29	31132562	4	SCREW TSVEI M6X16 UNI 5933	
3	F0863997010	1	SCREW M12X50 UNI 5737	
30	31112093	4	SCREW TE M6X20 UNI 5739 8G	
31	F0814547000	4	SELFLOCK NUT M6	
4	F0863951000	1	SCREW M12X45 UNI 5737	

SERIAL

CENTRAL SECTION

CODE REV

C.02.04_0_39172

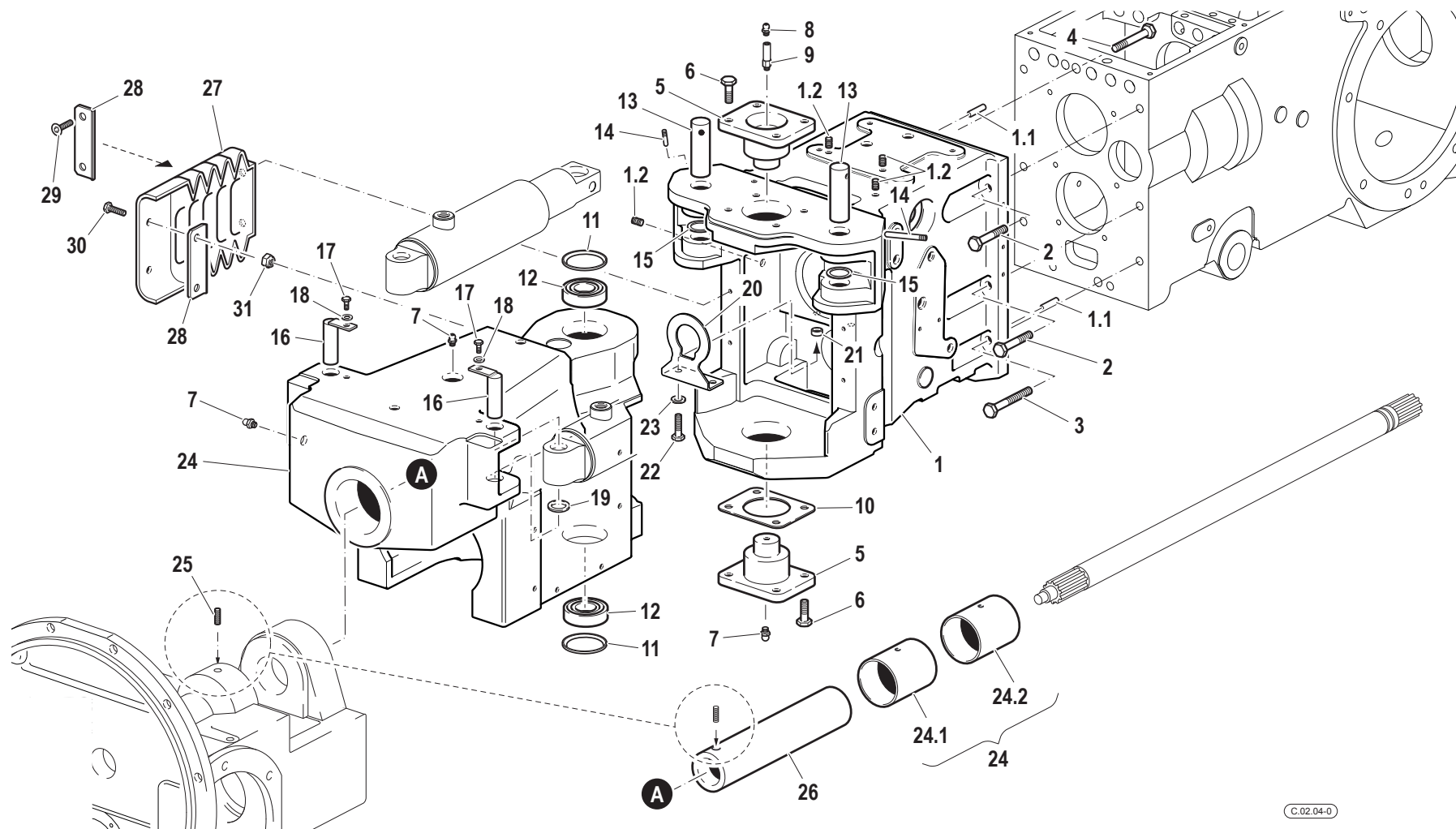

Pos.	Code	Q.ty	Description	Notes
5	52373668	2	JOINT PIN	
6	F0863267050	8	SCREW M10x25	
7	F0826056000	2	LUBRICATOR M10 UNI 7663A	
8	F0826056000	1	LUBRICATOR M10 UNI 7663A	
9	56174493	1	EXTENSION	

CENTRAL SECTION

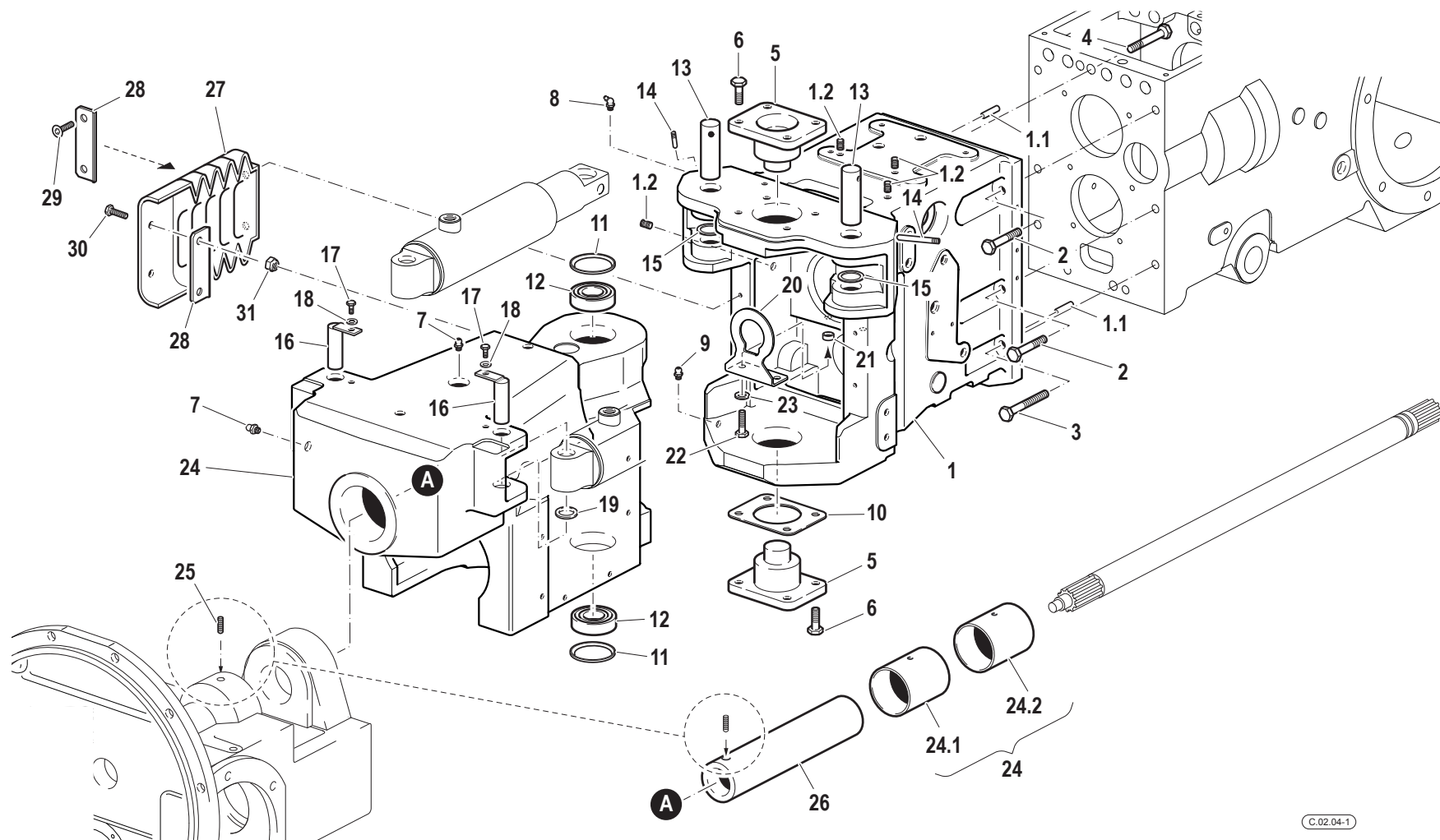

Pos.	Code	Q.ty	Description	Notes
1	59276003	1	BOX	
1.1	56570016	2	CYLINDRICAL PLUG	
1.2	58079118	1	ROD	
10	52173669	1	SHIM	
10	52173670	1	SHIM	
10	52173671	1	SHIM	
10	52173672	1	SHIM	
10	52173673	1	SHIM	
11	58170077	2	GASKET	
12	F0812838000	2	BEARING 32007 (35x62x18 R)	
13	56374556	2	HINGE PIN	
14	56370178	2	SCREW	
15	56374557	2	SPACER	
16	59070838	2	HINGE PIN	
17	31111151	2	SCREW TE M8X16 UNI 5739 8G	
18	F0843643060	2	WASHER 8	
19	F0844240000	2	WASHER 20,5x33/3	
2	F0863925000	7	SCREW M12X40 UNI 5737	
20	59075813	1	BRACKET	
21	56170364	2	SPACER	
22	31112146	2	SCREW TE M8X22 UNI 5739 8G	
23	F0843643060	2	WASHER 8	
24	59276002	1	BOX	
24.1	56276372	1	BUSHING	
24.2	56276371	1	BUSHING	
25	58077226	1	GRAIN	
26	56477227	1	PIN	
27	55174429	2	BELLOWS	
28	56174446	4	FIXING BRACKET	
29	31132562	4	SCREW TSVEI M6X16 UNI 5933	
3	F0863997010	1	SCREW M12X50 UNI 5737	
30	31112093	4	SCREW TE M6X20 UNI 5739 8G	
31	F0814547000	4	SELFLOCK NUT M6	
4	F0863951000	1	SCREW M12X45 UNI 5737	

SERIAL

914705

CENTRAL SECTION

CODE REV

C.02.04_1_39212

CENTRAL SECTION

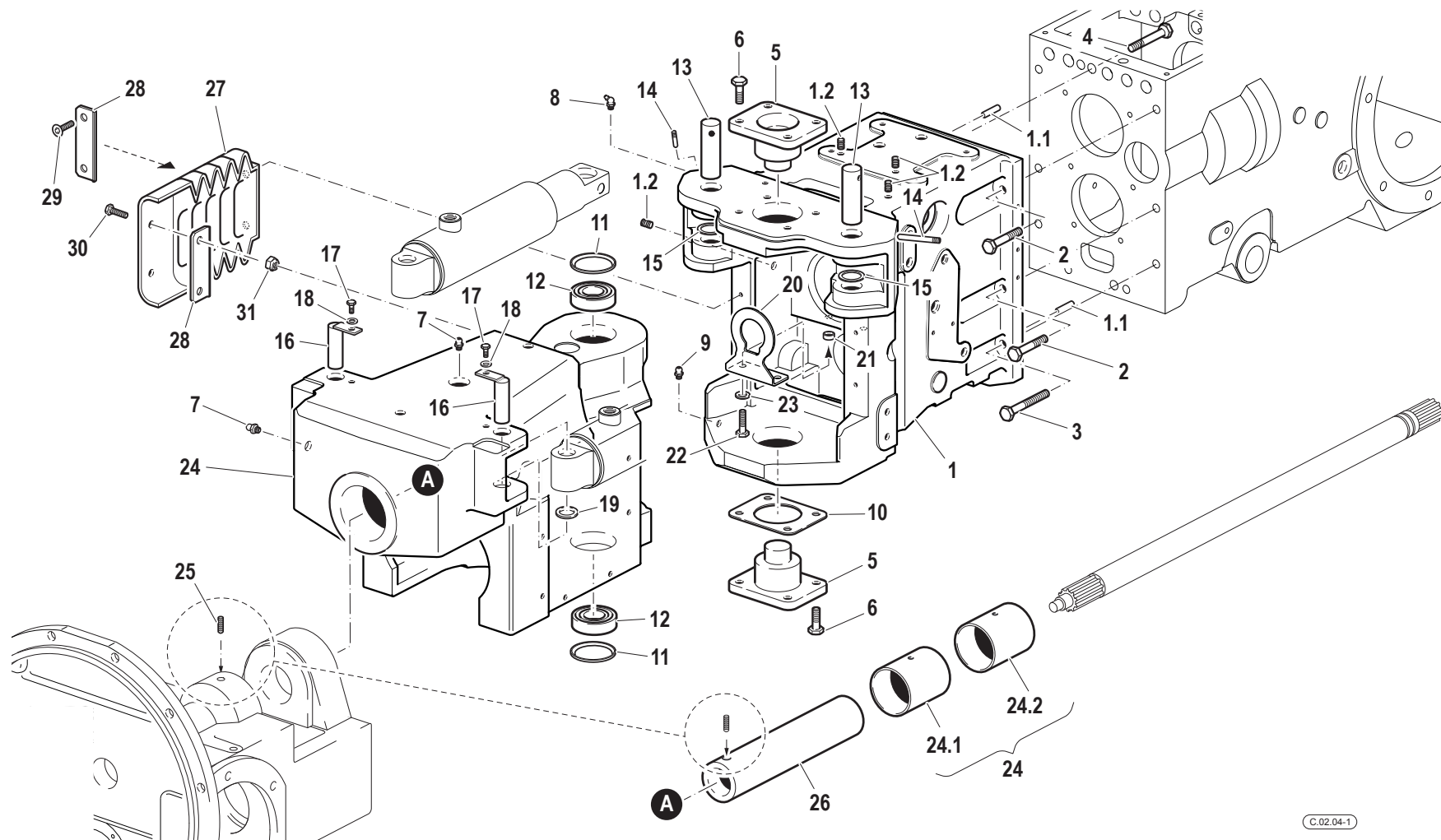

Pos.	Code	Q.ty	Description	Notes
5	52379209	2	JOINT PIN	
6	F0863267050	8	SCREW M10x25	
7	F0826056000	2	LUBRICATOR M10 UNI 7663A	
8	30000005	1	LUBRICATOR M10	
9	30000007	1	LUBRICATOR	

SERIAL

914705

CENTRAL SECTION

CODE REV

C.02.04_1_39212

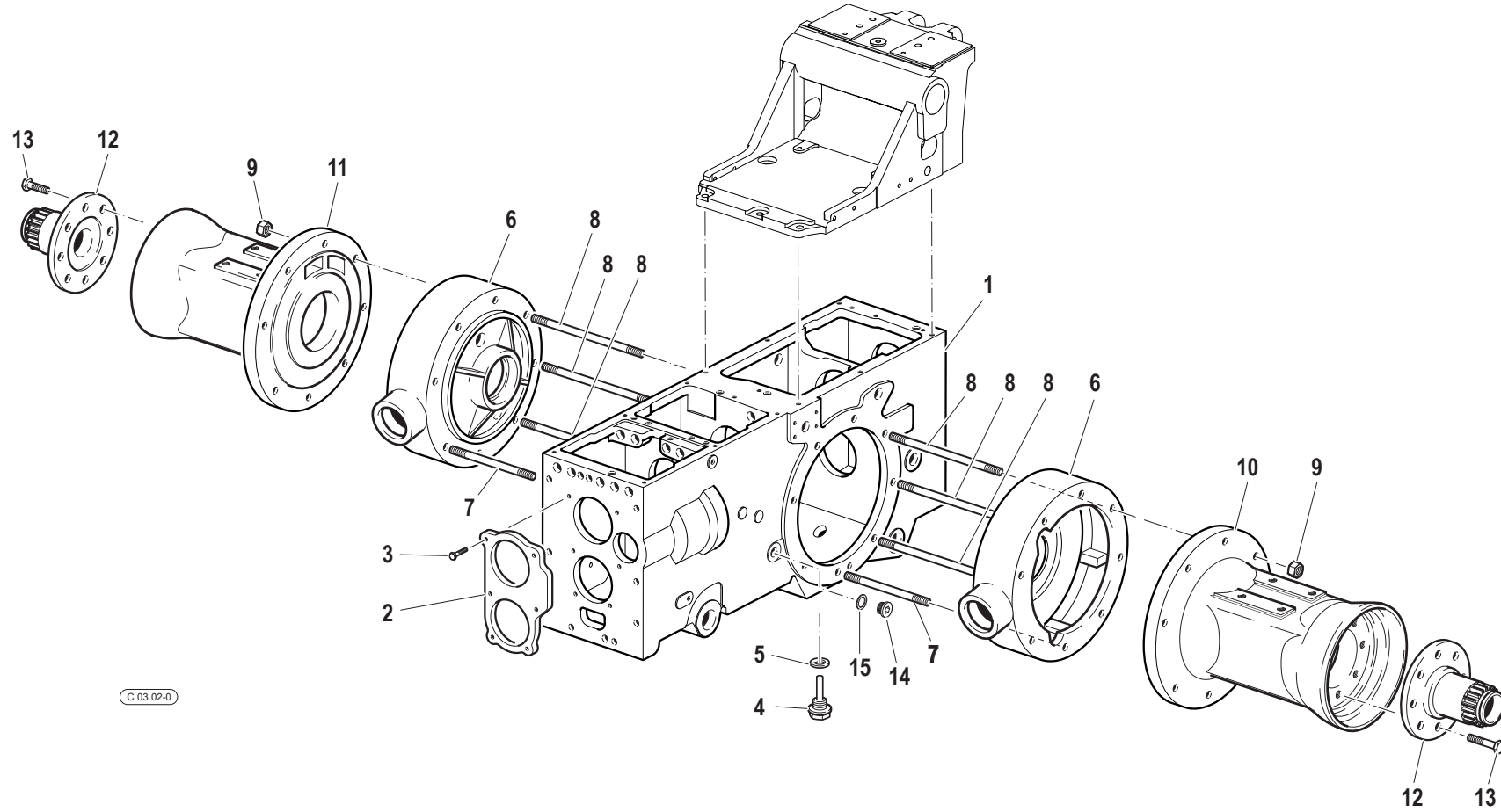

C.03.02-0

Pos.	Code	Q.ty	Description	Notes
1	51176123	1	GEAR BOX	
10	51176033	1	REAR AXLE HOUSING	
11	51176034	1	REAR AXLE HOUSING	
12	56373800	2	SUPPORT	
13	F0863890010	16	SCREW M12x1,75x35	
14	30040035	1	PLUG M18x1,5 DIN908	
15	F0824113000	1	COPPER WASHER 18X24/1,5	
2	51173650	1	FRONT COVER	
3	31112151	6	SCREW TE M8X25 UNI 5739 8G	
4	58170021	1	PLUG	
5	F0844273090	1	GASKET 22X28X1,5 CU 99,5	
6	51170020	2	BRAKE HOUSING	
7	31313300	10	STUD BOLT M14X1,5X105	
8	31313320	6	STUD BOLT M14X1,5X120	
9	F0814750010	16	NUT M14X1,5	

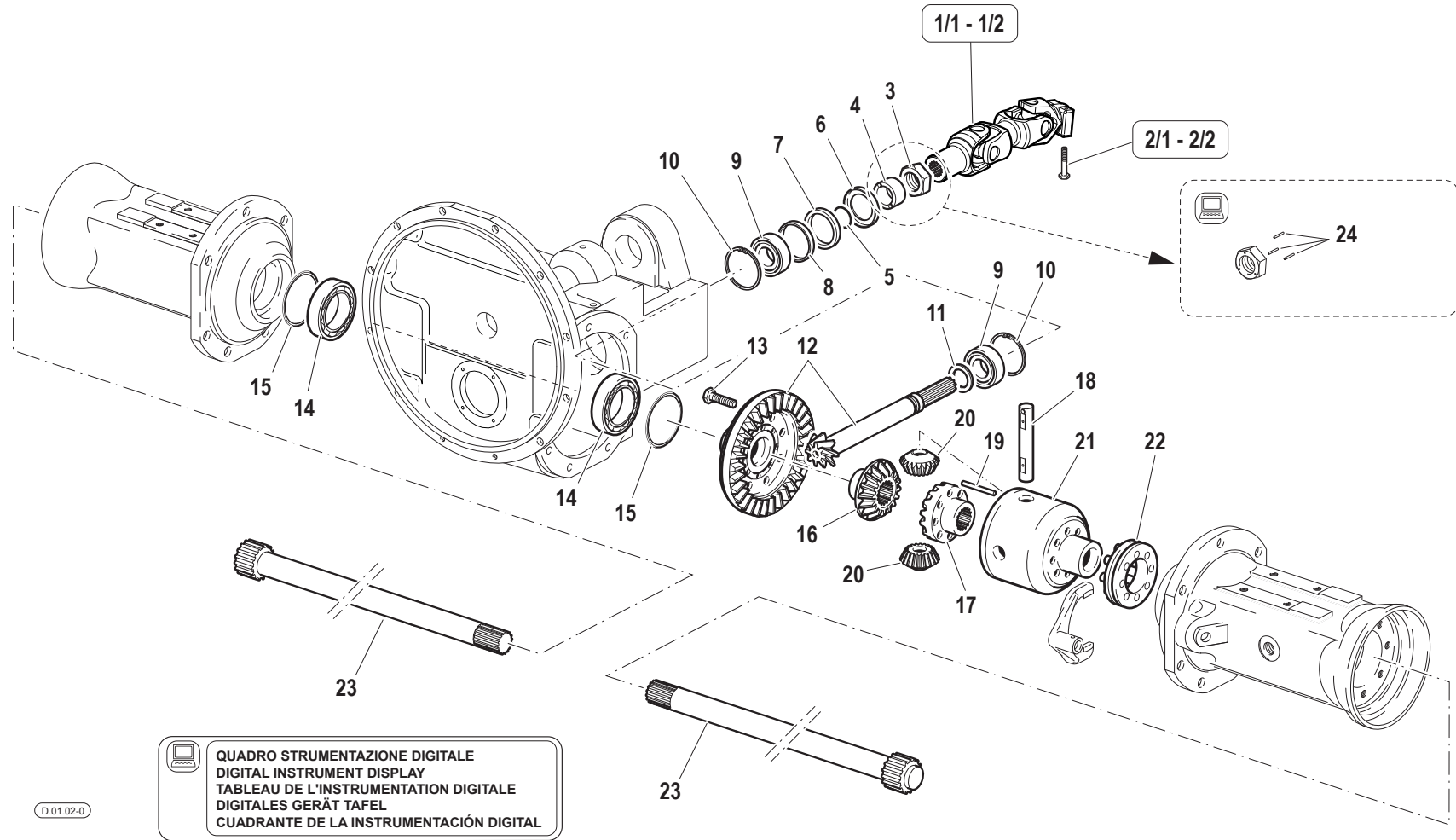

D.01.02-0

QUADRO STRUMENTAZIONE DIGITALE
DIGITAL INSTRUMENT DISPLAY
TABLEAU DE L'INSTRUMENTATION DIGITALE
DIGITALES GERÄT TAFEL
CUADRANTE DE LA INSTRUMENTACIÓN DIGITAL

Pos.	Code	Q.ty	Description	Notes
1/1	58178873	1	JOINT	
1/2	58178811	1	JOINT	
10	F0801422010	2	SEEGER RING I 72x3	
11	56370209	1	SHIM	
11	56370210	1	SHIM	
11	56370211	1	SHIM	
11	56370212	1	SHIM	
12	59376519	1	BEVEL GEAR	
13	F0863311250	8	SCREW M10x1,5x32	
14	F0812956000	2	BEARING 32010 X/Q	
15	56370089	1	RING	
15	56370127	1	RING	
15	56370128	1	RING	
16	52470062	1	PINION	
17	52470061	1	PINION	
18	56471036	1	PIN	
19	56371037	1	PIN	
2/1	F0862785000	1	SCREW M8X40 UNI 5737	
2/2	31111156	1	SCREW TE M8X50 UNI 5737 CL 10.9	
20	52470067	2	DIFFERENTIAL PINION	
21	51371035	1	HOUSING	
22	59070065	1	SLEEVE	
23	56470813	2	AXLE SHAFT	
24	F0851044000	3	PIN 3,0X26 DIN 1481 CL:C72	
3	56372536	1	RING NUT	
4	56470215	1	SPACER	
5	F0803078100	1	O-RING 2125	
6	56170214	1	PROTECTIVE RING D=72	
7	F0802239045	1	SEAL 50x72x8	
8	56170213	1	SPACER	
9	F0812859000	2	BEARING 32207	

CLUTCH FRONT SHAFT/ TRANSMISSION CLUTCH

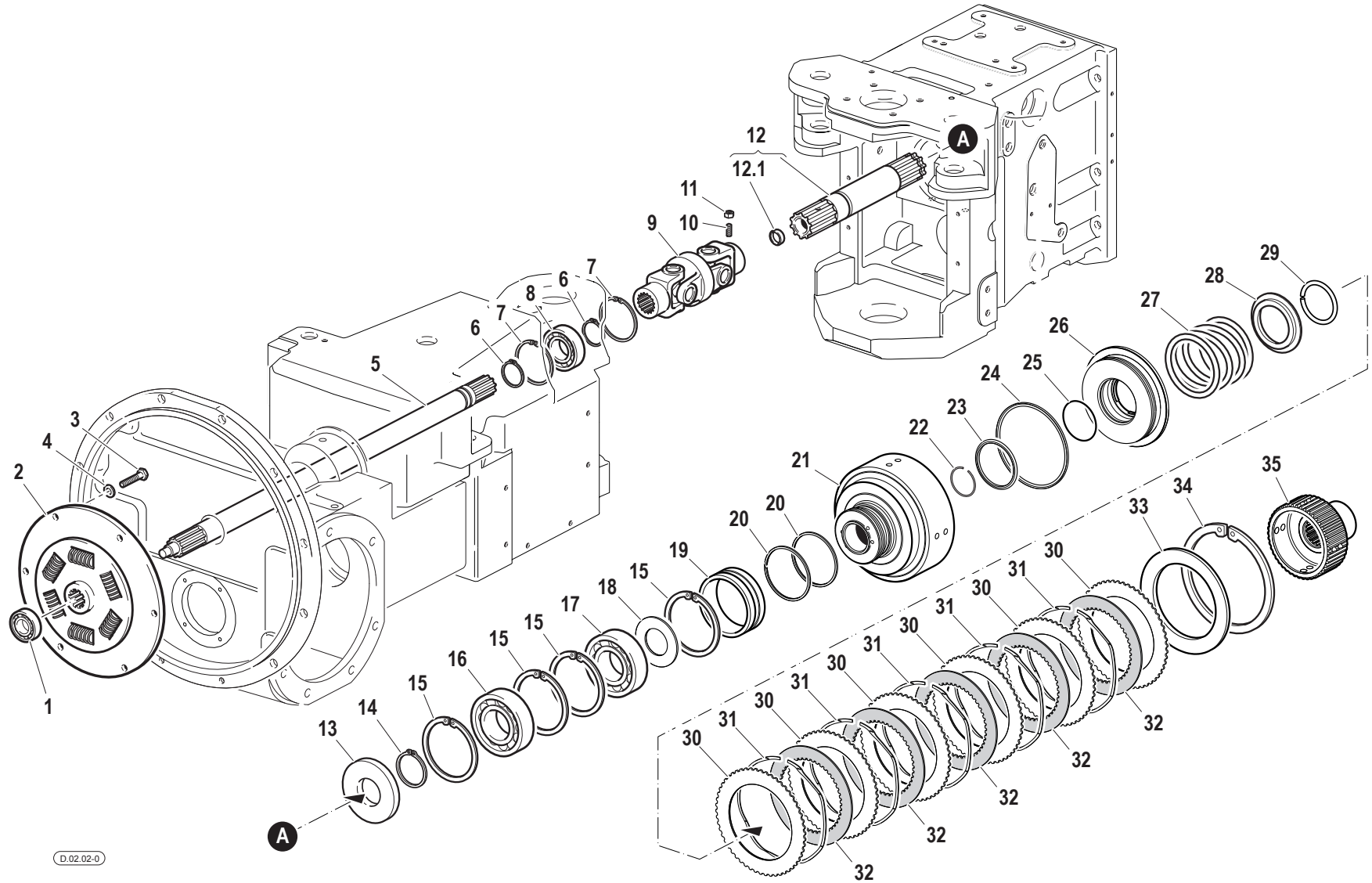

Pos.	Code	Q.ty	Description	Notes
1	F0812523050	1	BEARING 6201-2RS	
10	F0862657000	1	GRAIN	
11	31211080	1	NUT M8	
12	52473660	1	SHAFT	
12.1	58073461	1	PLUG	
13	F0802163010	1	SEAL 35x80/10	
14	F0801264050	1	SEEGER RING E 35X2,5 U/7436	
15	35111080	4	SEEGER RING I 80 DIN 472	
16	37111354	1	BEARING	
17	F0812868100	1	BEARING 6307-2Z (35x80x21)	
18	56371162	1	SHIM	
19	56470002	1	BUSHING	
2	58177653	1	JOINT	
20	58170306	2	SEAL	
21	52573648	1	CLUTCH HOUSING	
22	F0801266100	1	SAFETY RING	
23	58170443	1	GASKET	
24	58172400	1	GASKET	
25	38104412	1	O-RING 3175 (44,12X2,62)	
26	53273025	1	PISTON	
27	58070262	1	RESTORING SPRING	
28	56370267	1	RING	
29	58070268	1	CIRCLIP	
3	31112150	6	SCREW TE M8X20 UNI 5739 8G	
30	58170034	6	DISC	
31	58172106	5	SPRING	
32	58172105	5	DISC	
33	56370037	1	CLUTCH DISC	
34	F0801455100	1	SEEGER RING I 135 UNI 7437	
35	52473655	1	HUB	
4	31421083	6	WASHER	
5	56573661	1	FRONT CLUTCH SHAFT	
6	35121030	2	SEEGER RING E 30 DIN 471	
7	35111062	2	SEEGER RING I 62 DIN 472	

SERIAL

CLUTCH FRONT SHAFT/ TRANSMISSION CLUTCH

CODE REV

D.02.02_0_39318

CLUTCH FRONT SHAFT/ TRANSMISSION CLUTCH

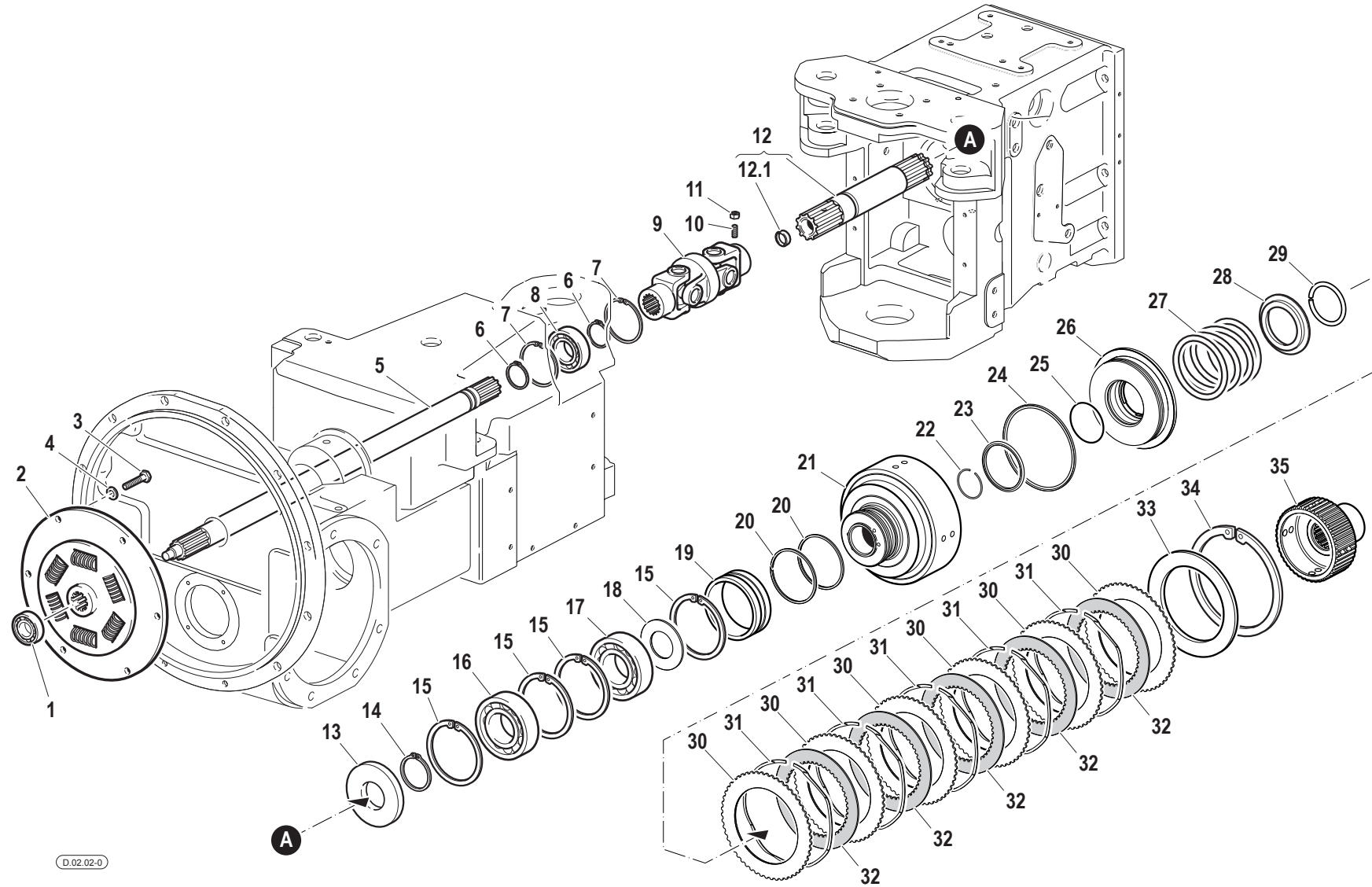

Pos.	Code	Q.ty	Description	Notes
8	37112302	1	BEARING	
9	58173664	1	CARDAN JOINT	

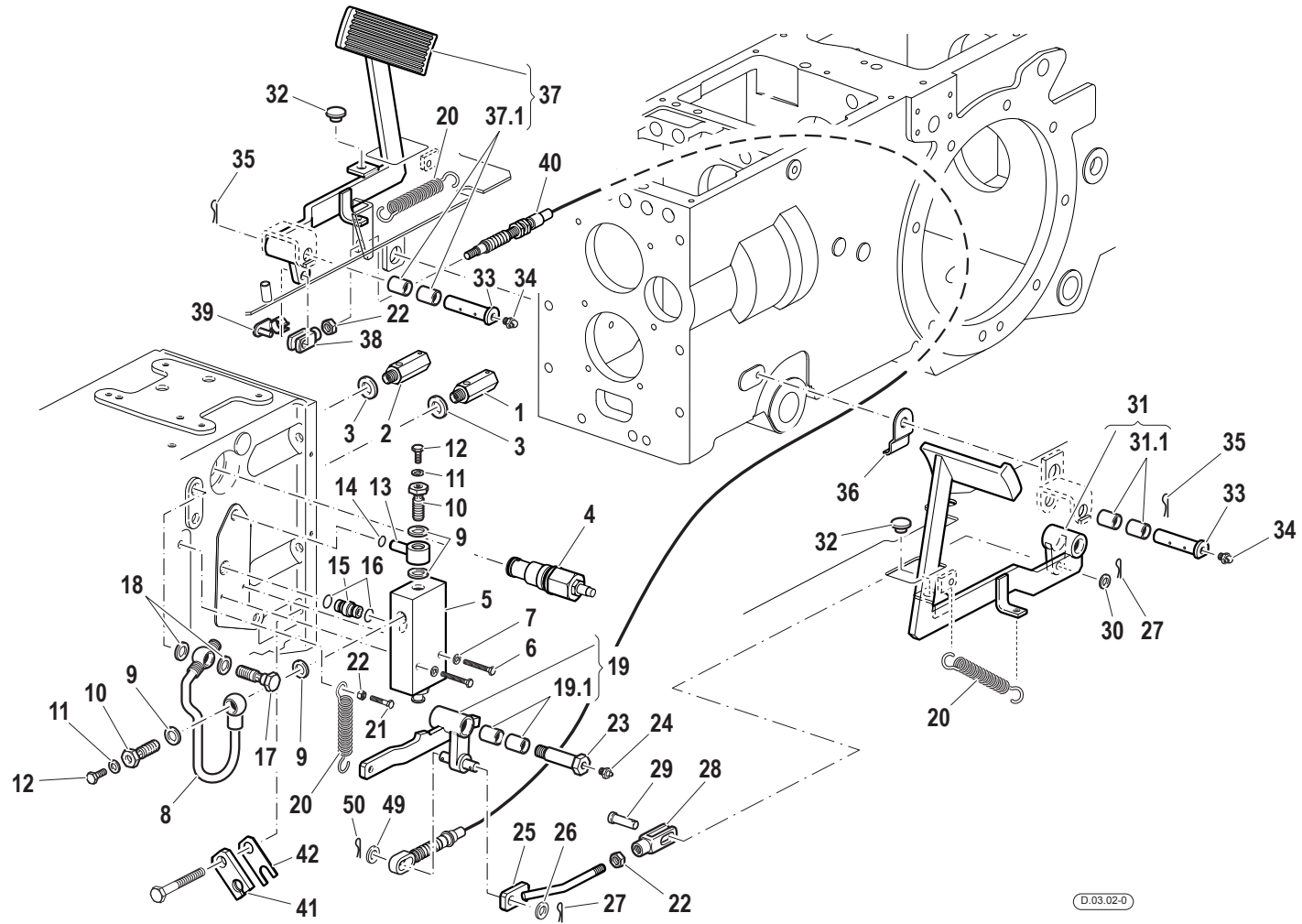

Pos.	Code	Q.ty	Description	Notes
1	59278554	1	VALVE	
10	58074558	2	PIPE FITTING	
11	F0843641000	2	COPPER WASHER 8x14/1,5	
12	F0862448100	2	SCREW M8X10 UNI 5740	
13	59074623	1	PRESSURE PIPE	
14	38110992	1	O-RING 112 (9,92X2,62)	
15	56170029	1	PIPE FITTING	
16	F0803057000	2	O-RING 2037	
17	F0843109020	1	PIPE FITTING	
18	F0824110000	2	COPPER WASHER 3/8 GAS	
19	59073725	1	ROCKER	
19.1	58173195	2	BUSHING	
2	59278555	1	VALVE	
20	58070790	2	RESTORING SPRING	
21	F0862694000	1	SCREW M8X170 UNI 5737	
22	F0814569000	2	NUT M8 UNI 5589 CL:8	
23	56173684	1	PIN	
24	30000007	1	LUBRICATOR	
25	59073685	1	ROD	
26	31411105	1	WASHER 10,5x21	
27	F0810510000	2	SPLIT PIN A2,0X20 UNI 1336	
28	56074302	1	FORK	
29	F0835523000	1	PIN	
3	F0843841000	2	COPPER WASHER 12,0x18/1,5	
30	31411084	1	WASHER 8,4x17	
31	59074206	1	CLUTCH PEDAL	
31.1	58173195	2	BUSHING	
32	F0822537050	1	BUFFER	
33	56373194	1	HINGE PIN	
34	F0826039000	1	LUBRICATOR	
35	F0810527000	1	SPLIT PIN A2,5X25 UNI 1336	
36	56075230	1	BRACKET	
37	59074081	1	PEDAL	
37.1	58173195	4	BUSHING	

SERIAL

CLUTCH CONTROLS

CODE REV

D.03.02_0_39758

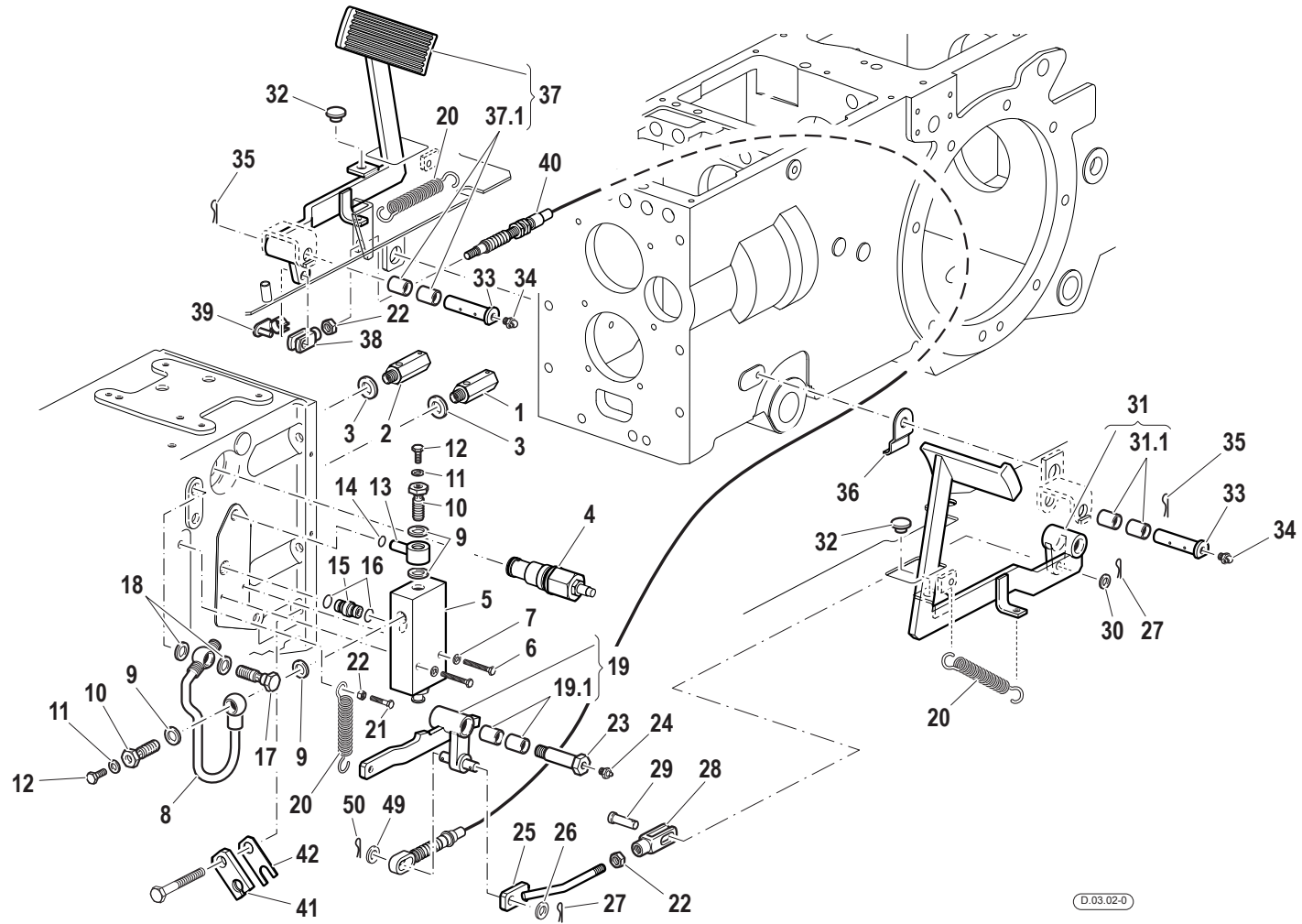

Pos.	Code	Q.ty	Description	Notes
38	F0860058010	1	FORK	
39	F0860058020	1	PIN	
4	58173961	1	VALVE	
40	58174417	1	CABLE	
41	56174400	1	PLATE	
42	56174401	1	FIXING PLATE	
5	58173030	1	SWITCH	
6	F0862345000	2	SCREW M6X40 UNI 5737	
7	F0843581010	2	SPRING WASHER 6	
8	59074741	1	PIPE	
9	F0843907000	4	COPPER WASHER 13,66x19/1,5	

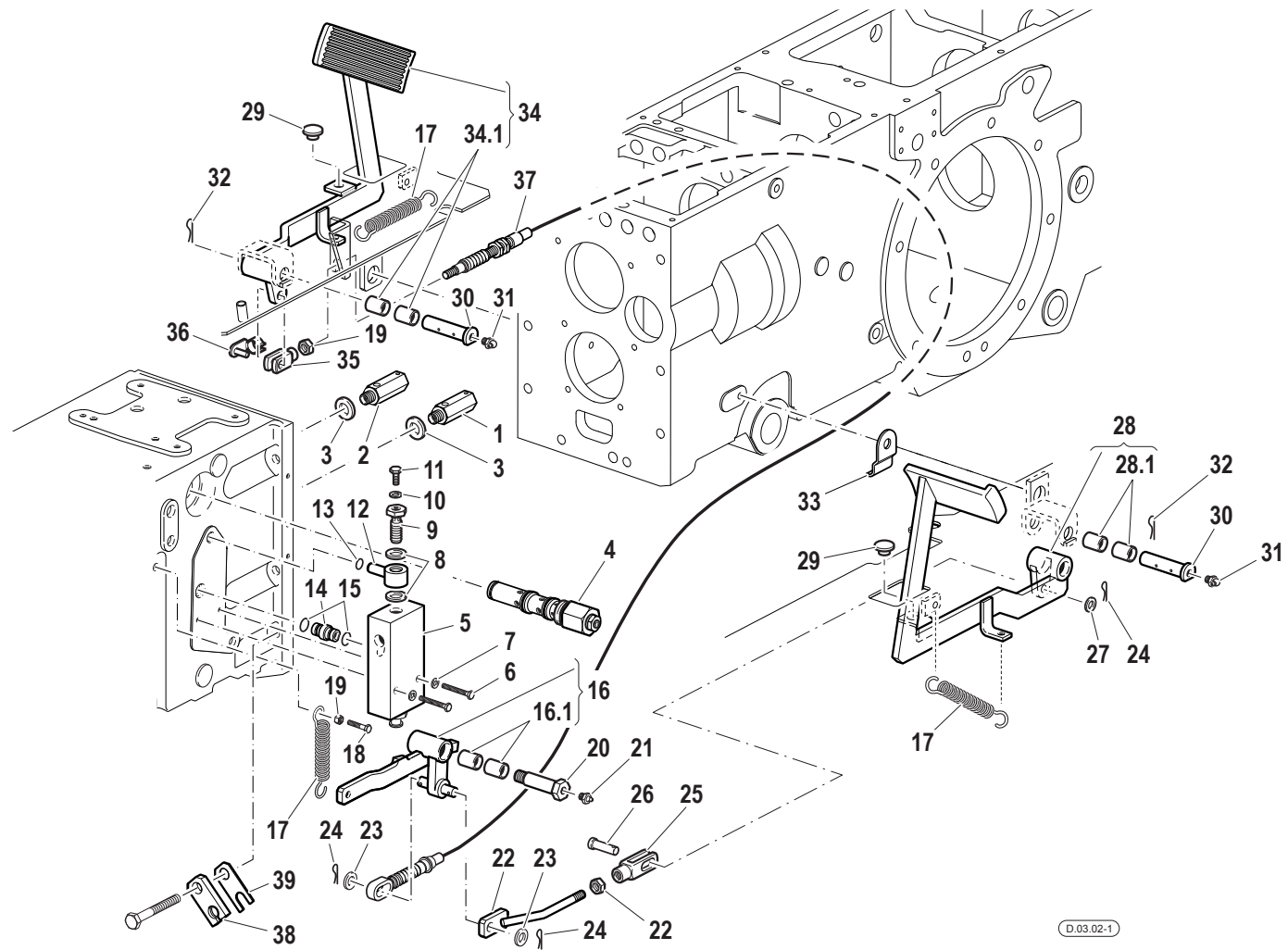

Pos.	Code	Q.ty	Description	Notes
1	59278554	1	VALVE	
10	F0843641000	1	COPPER WASHER 8x14/1,5	
11	F0862448100	1	SCREW M8X10 UNI 5740	
12	59074623	1	PRESSURE PIPE	
13	38110992	1	O-RING 112 (9,92X2,62)	
14	56170029	1	PIPE FITTING	
15	F0803057000	2	O-RING 2037	
16	59073725	1	ROCKER	
16.1	58173195	2	BUSHING	
17	58070790	3	RESTORING SPRING	
18	F0862694000	1	SCREW M8X170 UNI 5737	
19	F0814569000	2	NUT M8 UNI 5589 CL:8	
2	59278555	1	VALVE	
20	56173684	1	PIN	
21	30000007	1	LUBRICATOR	
22	59073685	1	ROD	
23	31411105	2	WASHER 10,5x21	
24	F0810510000	2	SPLIT PIN A2,0X20 UNI 1336	
25	56074302	1	FORK	
26	F0835523000	1	PIN	
27	31411084	1	WASHER 8,4x17	
28	59074206	1	CLUTCH PEDAL	
28.1	58173195	2	BUSHING	
29	F0822537050	1	BUFFER	
3	F0843841000	2	COPPER WASHER 12,0x18/1,5	
30	56373194	2	HINGE PIN	
31	F0826039000	2	LUBRICATOR	
32	F0810527000	2	SPLIT PIN A2,5X25 UNI 1336	
33	56075230	1	BRACKET	
34	59074081	1	PEDAL	
34.1	58173195	4	BUSHING	
35	F0860058010	1	FORK	
36	F0860058020	1	PIN	
37	58174417	1	CABLE	

SERIAL

914705

CLUTCH CONTROLS

CODE REV

D.03.02_1_39804

CLUTCH CONTROLS

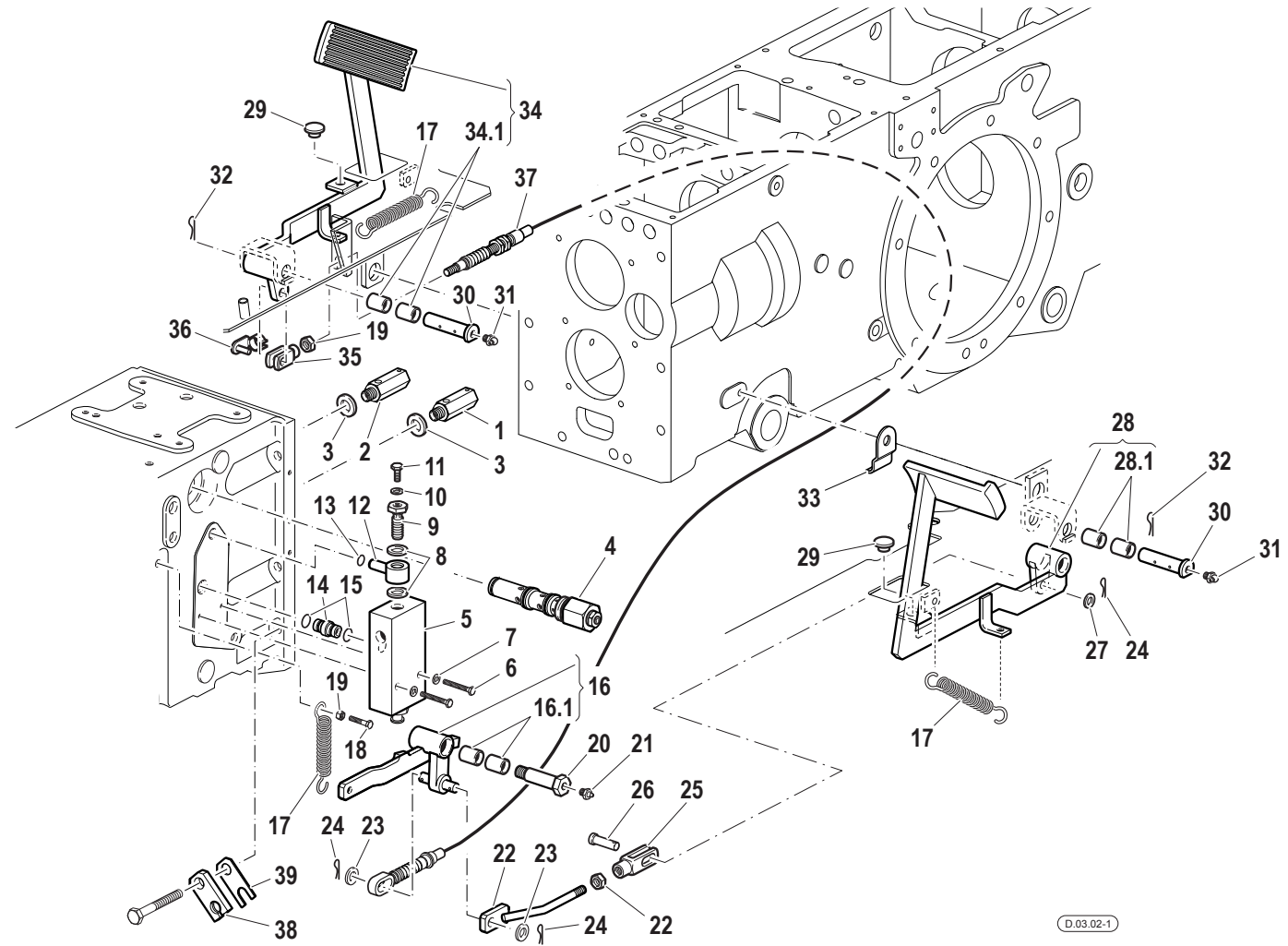

Pos.	Code	Q.ty	Description	Notes
38	56174400	1	PLATE	
39	56174401	1	FIXING PLATE	
4	58177754	1	VALVE	
5	58173030	1	SWITCH	
6	F0862345000	2	SCREW M6X40 UNI 5737	
7	F0843581010	2	SPRING WASHER 6	
8	F0843907000	2	COPPER WASHER 13,66x19/1,5	
9	58074558	1	PIPE FITTING	

SERIAL

914705

CLUTCH CONTROLS

CODE REV

D.03.02_1_39804

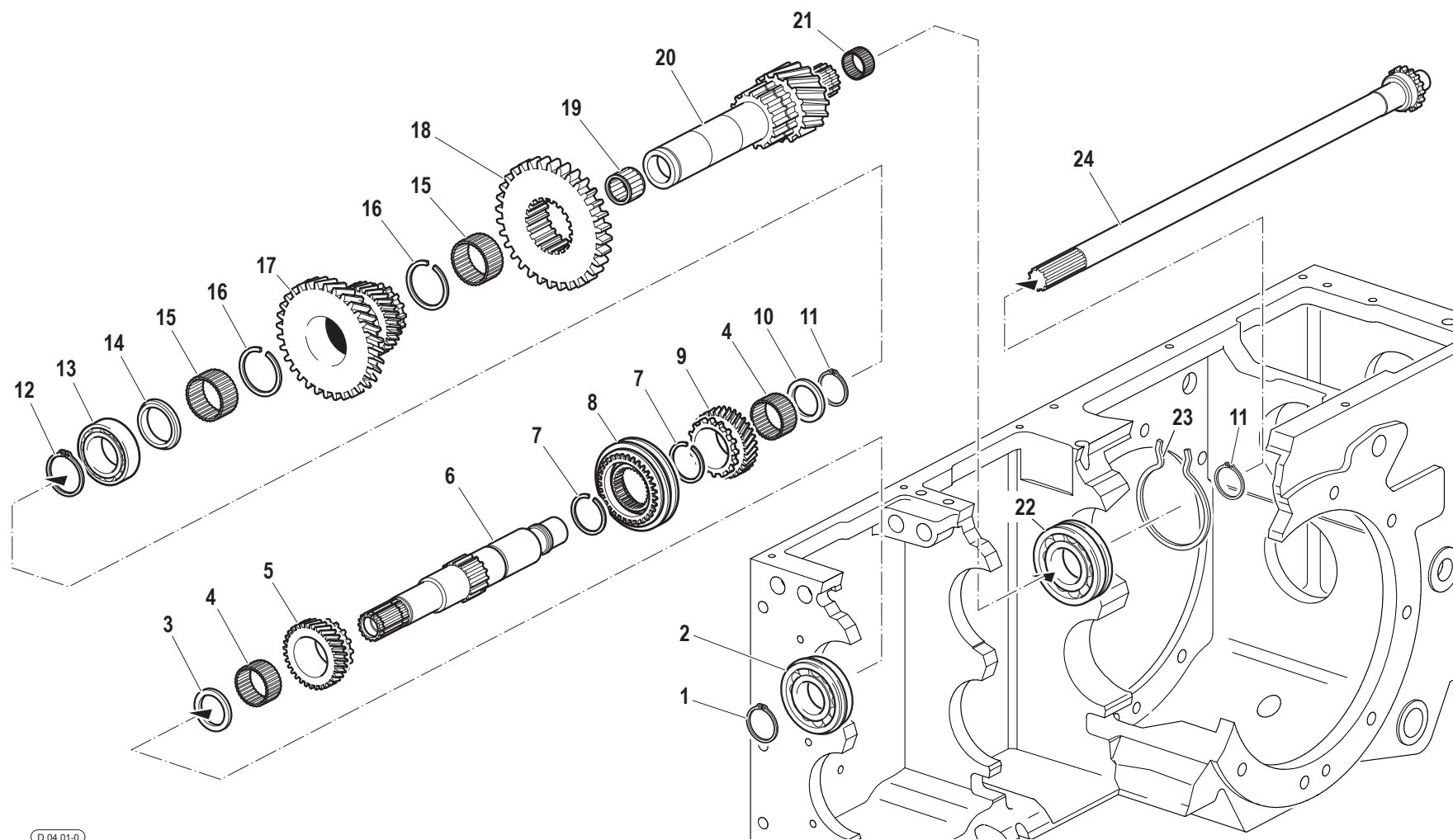

Pos.	Code	Q.ty	Description	Notes
1	F0801264050	1	SEEGER RING E 35X2,5 U/7436	
10	56470139	1	SHIM	
11	35121040	1	SEEGER RING E 40 DIN 471	
12	F0801353000	1	SEEGER RING E 50 UNI 7435	
13	37112501	1	BEARING	
14	56470111	1	SHIM	
15	F0812951200	2	ROLLER CAGE K 50X55/20 H	
16	F0801380100	2	SAFETY RING	
17	52474254	1	DOUBLE GEAR	
18	52470762	1	SLIDING GEAR	
19	F0812783000	1	ROLLER CAGE K 32X38/20	
2	F0812868000	1	BEARING 6307-NR	
20	52475073	1	OUTPUT SHAFT	
21	F0812660020	1	ROLLER CAGE K 22X26/17	
22	F0812918010	1	BEARING 6308-NR (40x90x23)	
23	58170130	1	CIRCLIP	
24	52473656	1	SHAFT	
3	56470110	1	SHIM	
4	F0812878040	2	ROLLER CAGE K 40X45/27	
5	52473838	1	DRIVEN GEAR	
6	56473818	1	SHAFT	
7	F0801331150	2	SAFETY RING	
8	58170279	1	LOCK SYNCHRONIZER	
9	52473839	1	GEAR	

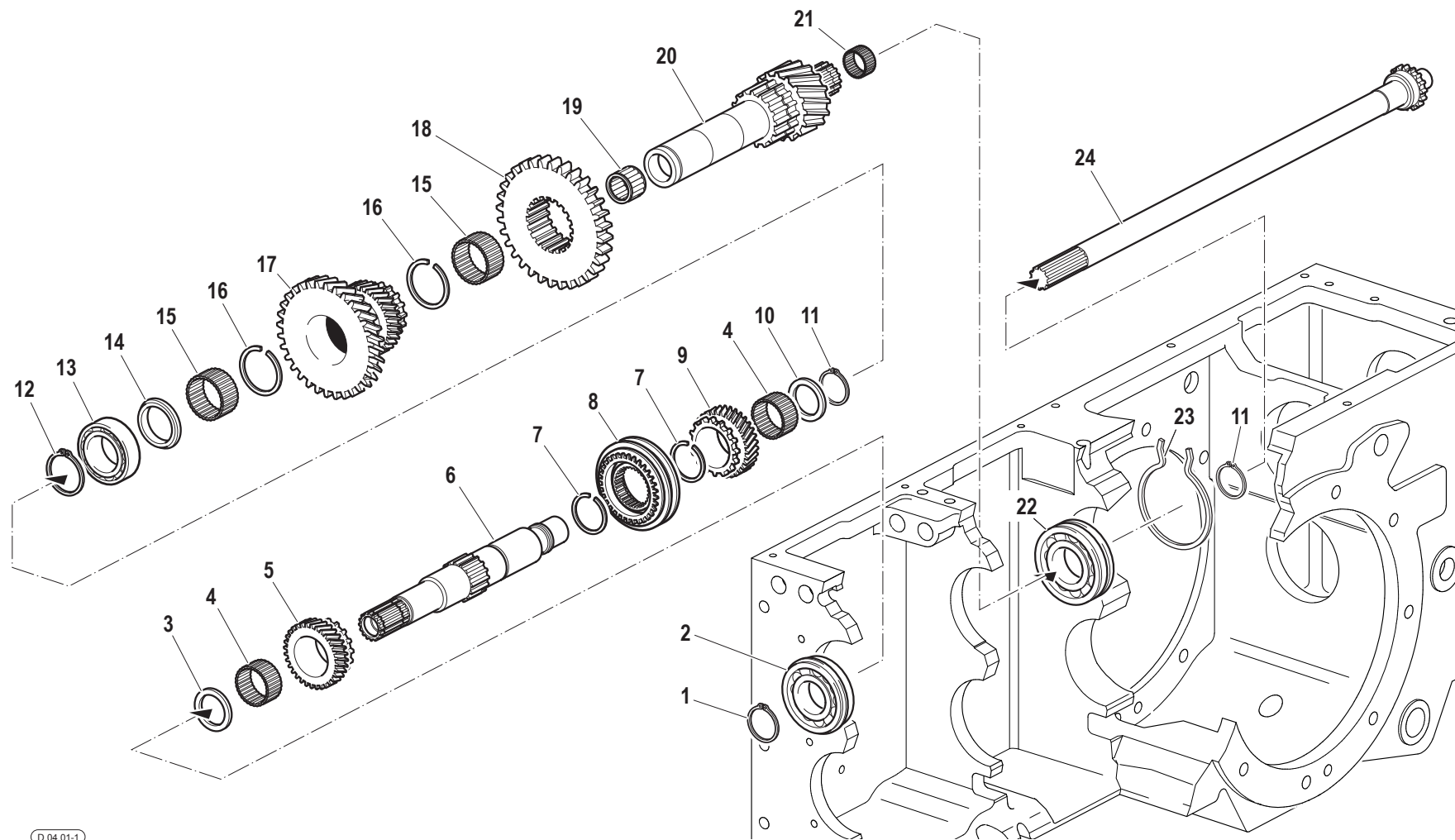

Pos.	Code	Q.ty	Description	Notes
1	F0801264050	1	SEEGER RING E 35X2,5 U/7436	
10	56470139	1	SHIM	
11	35121040	1	SEEGER RING E 40 DIN 471	
12	F0801353000	1	SEEGER RING E 50 UNI 7435	
13	37112501	1	BEARING	
14	56470111	1	SHIM	
15	F0812951200	2	ROLLER CAGE K 50X55/20 H	
16	F0801380100	2	SAFETY RING	
17	52478618	1	DOUBLE GEAR	
18	52478619	1	GEAR	
19	F0812783000	1	ROLLER CAGE K 32X38/20	
2	F0812868000	1	BEARING 6307-NR	
20	52478620	1	OUTPUT SHAFT	
21	F0812660020	1	ROLLER CAGE K 22X26/17	
22	F0812918010	1	BEARING 6308-NR (40x90x23)	
23	58170130	1	CIRCLIP	
24	52473656	1	SHAFT	
3	56470110	1	SHIM	
4	F0812878040	2	ROLLER CAGE K 40X45/27	
5	52473838	1	DRIVEN GEAR	
6	56473818	1	SHAFT	
7	F0801331150	2	SAFETY RING	
8	58170279	1	LOCK SYNCHRONIZER	
9	52473839	1	GEAR	

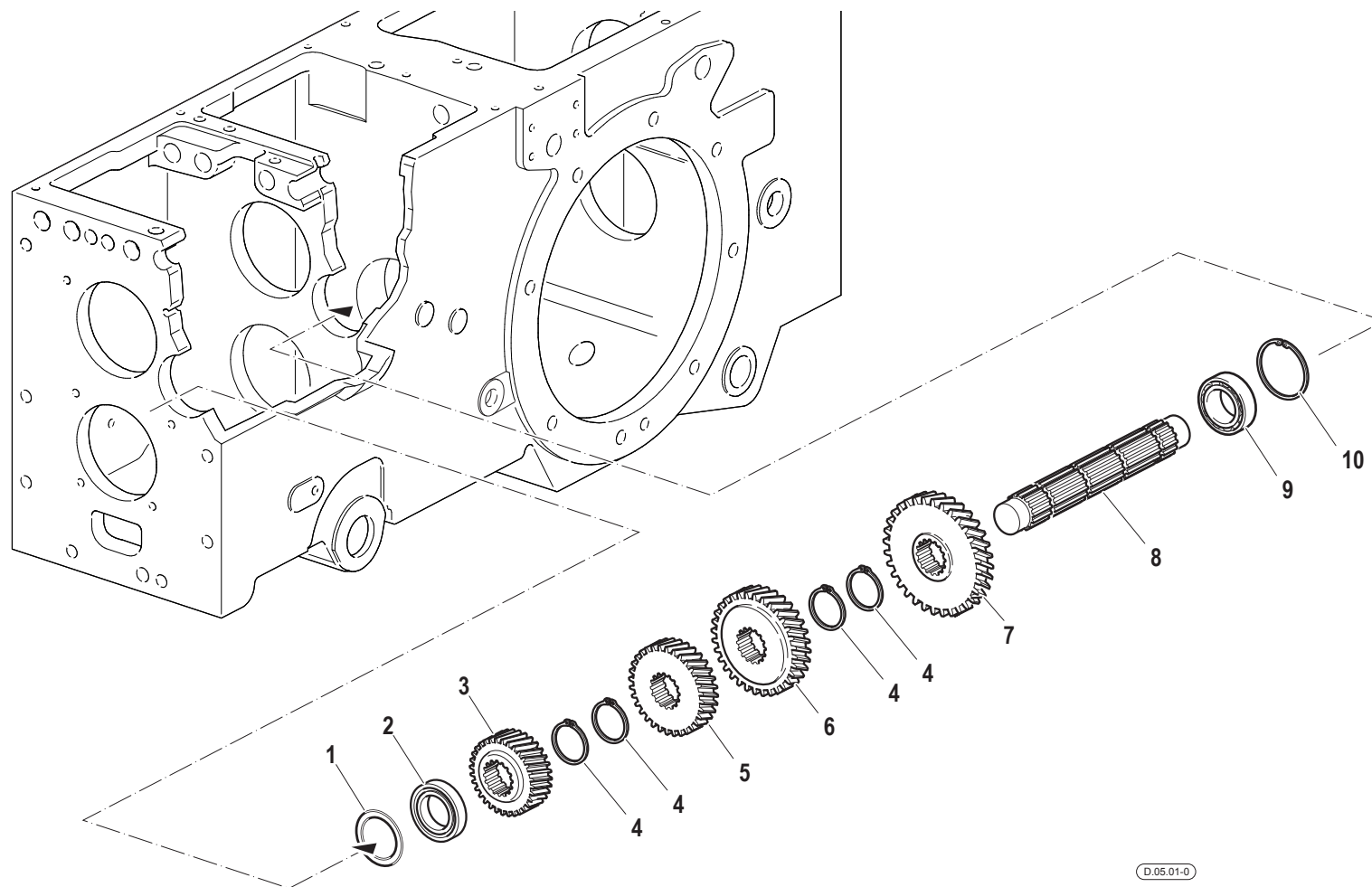

Pos.	Code	Q.ty	Description	Notes
1	F0850100000	1	SHIM 41x51/0,2	
1	F0850100010	1	SHIM 41x51/0,3	
1	F0850100020	1	SHIM 41x51/0,5	
10	35111052	1	SEEGER RING I 52 DIN 472	
2	F0812708030	1	BEARING NJ 205E	
3	52473828	1	GEAR	
4	F0801241010	4	SEEGER RING E 30 UNI 7436	
5	52473829	1	GEAR	
6	52473830	1	GEAR	
7	52473831	1	GEAR	
8	52473827	1	OUTPUT SHAFT	
9	37111255	1	BEARING	

GEARS MAIN SHAFT / GEARS

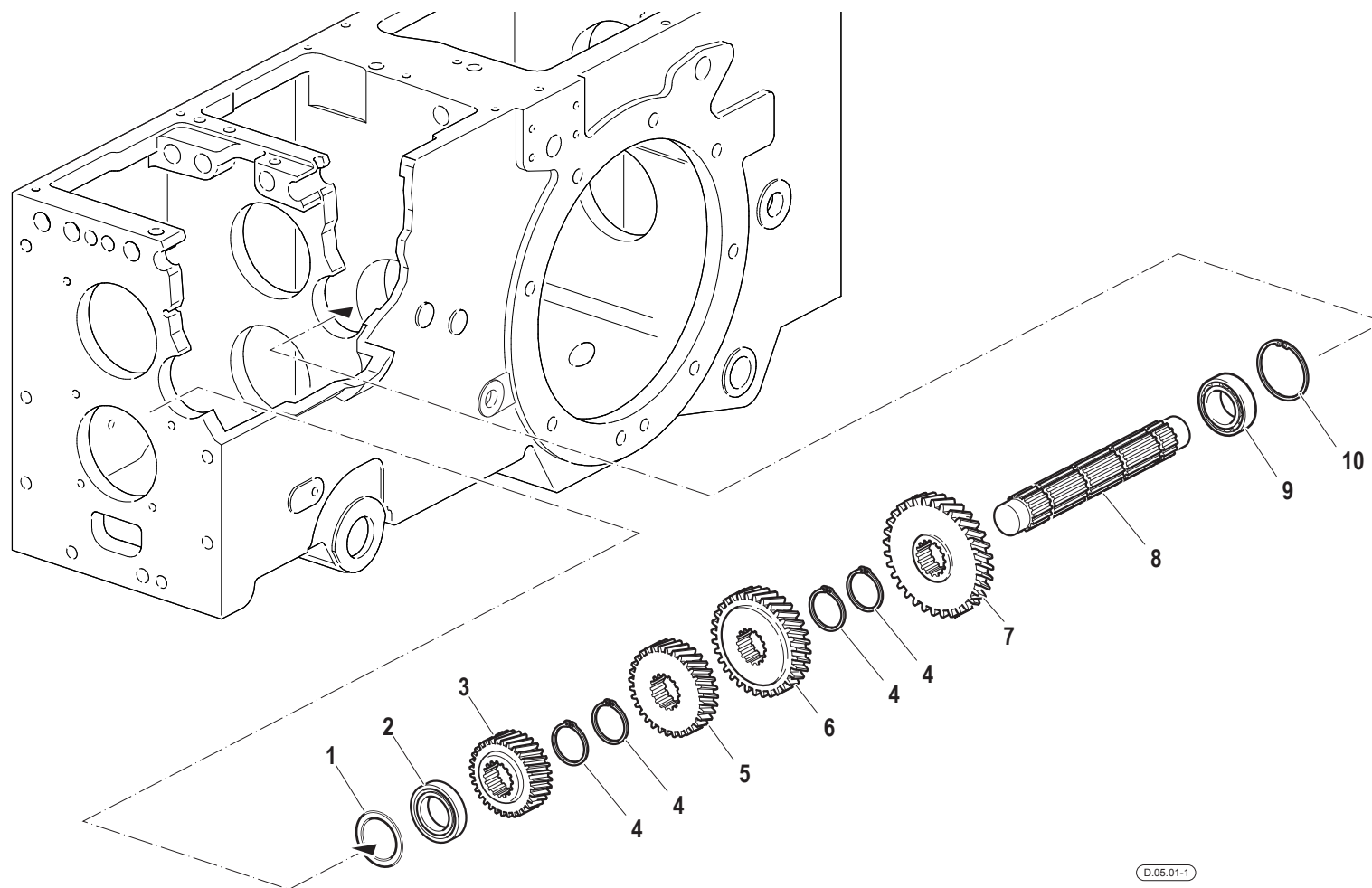

Pos.	Code	Q.ty	Description	Notes
1	F0850100000	1	SHIM 41x51/0,2	
1	F0850100010	1	SHIM 41x51/0,3	
1	F0850100020	1	SHIM 41x51/0,5	
10	35111052	1	SEEGER RING I 52 DIN 472	
2	F0812708030	1	BEARING NJ 205E	
3	52478612	1	GEAR	
4	F0801241010	4	SEEGER RING E 30 UNI 7436	
5	52473829	1	GEAR	
6	52473830	1	GEAR	
7	52473831	1	GEAR	
8	52473827	1	OUTPUT SHAFT	
9	37111255	1	BEARING	

GEARS TRANSMISSION SHAFT / GEARS

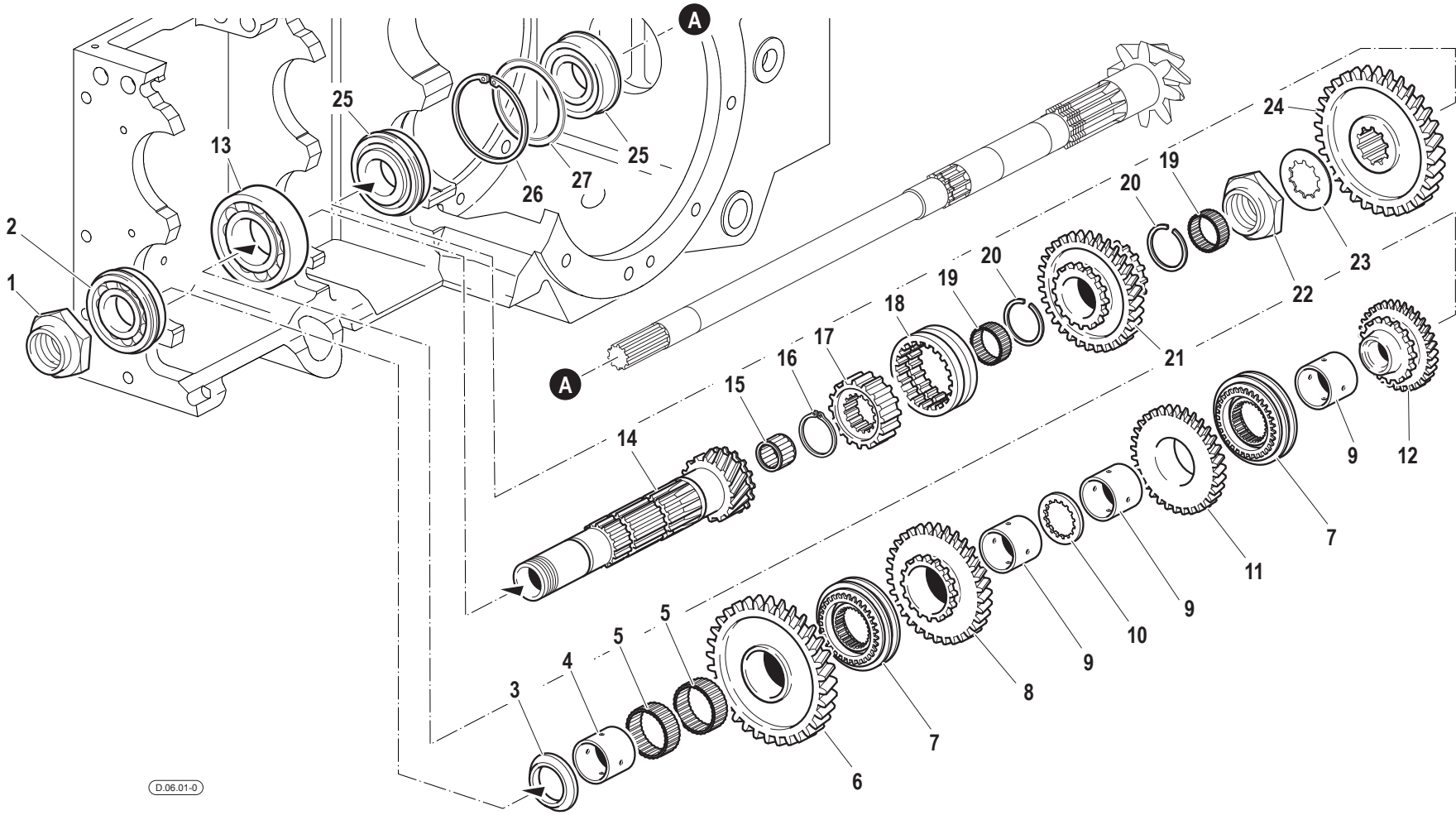

Pos.	Code	Q.ty	Description	Notes
1	56373840	1	RING NUT	
10	56470137	1	SHIM	
11	52473836	1	DRIVEN GEAR	
12	52473837	1	DRIVEN GEAR	
13	F0812957000	1	BEARING 6210 (50/90/20)	
14	52474251	1	COUNTERSHAFT	
15	F0812692015	1	ROLLER CAGE K 25X35/25	
16	35121035	1	SEEGER RING E 35 DIN 471	
17	52470118	1	SLEEVE	
18	52470117	1	SLIDING SLEEVE	
19	F0812811000	2	ROLLER CAGE K 35X40/17	
2	F0812899000	1	BEARING 6208-NR	
20	F0801299100	2	SAFETY RING	
21	52474253	1	DOUBLE GEAR	
22	56370761	1	RING NUT	
23	56170760	1	RETAINING WASHER SP.1,0	
23	56174692	1	RETAINING WASHER SP.0,8	
23	56174693	1	RETAINING WASHER SP.0,9	
23	56174694	1	RETAINING WASHER SP.1,1	
23	56174695	1	RETAINING WASHER SP.1,2	
23	56175367	1	RETAINING WASHER SP.1,3	
24	52474252	1	DRIVEN GEAR	
25	37221320	2	BEARING	
26	35111080	1	SEEGER RING I 80 DIN 472	
27	56370089	1	RING	
27	56370127	1	RING	
27	56370128	1	RING	
27	56370830	1	RING	
3	52473833	1	THRUST PLATE	
4	56570219	1	BUSHING	
5	F0812951070	2	ROLLER CAGE K 47X52/17 H	
6	52473834	1	DRIVEN GEAR	
7	58171139	2	LOCK SYNCHRONIZER	
8	52473835	1	DRIVEN GEAR	

SERIAL

GEARS TRANSMISSION SHAFT / GEARS

Version: RS-M, RS-R, AR-M, AR-R

CODE REV

D.06.01_0_42896

GEARS TRANSMISSION SHAFT / GEARS

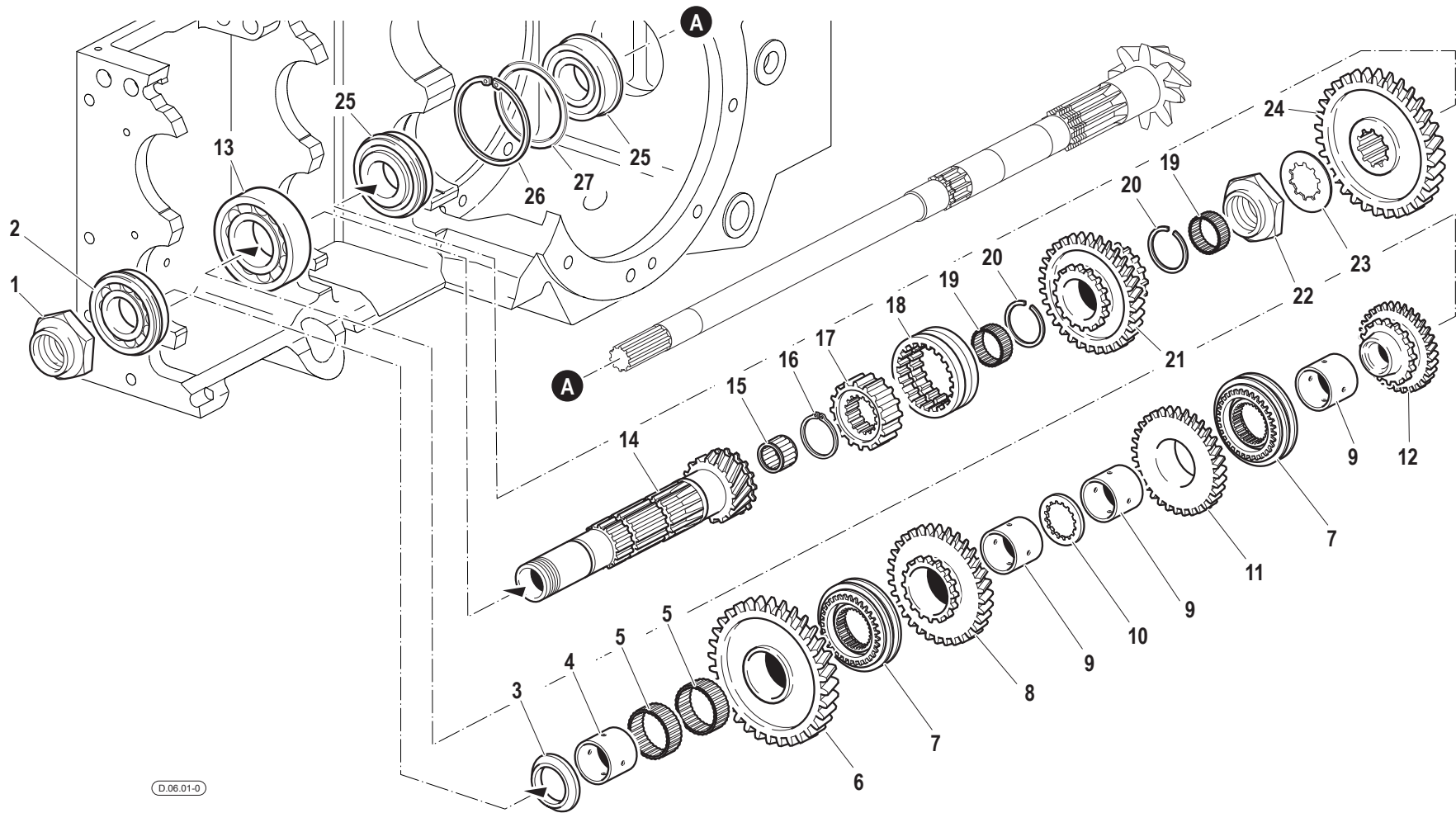

Pos.	Code	Q.ty	Description	Notes
9	56470138	3	BUSHING	

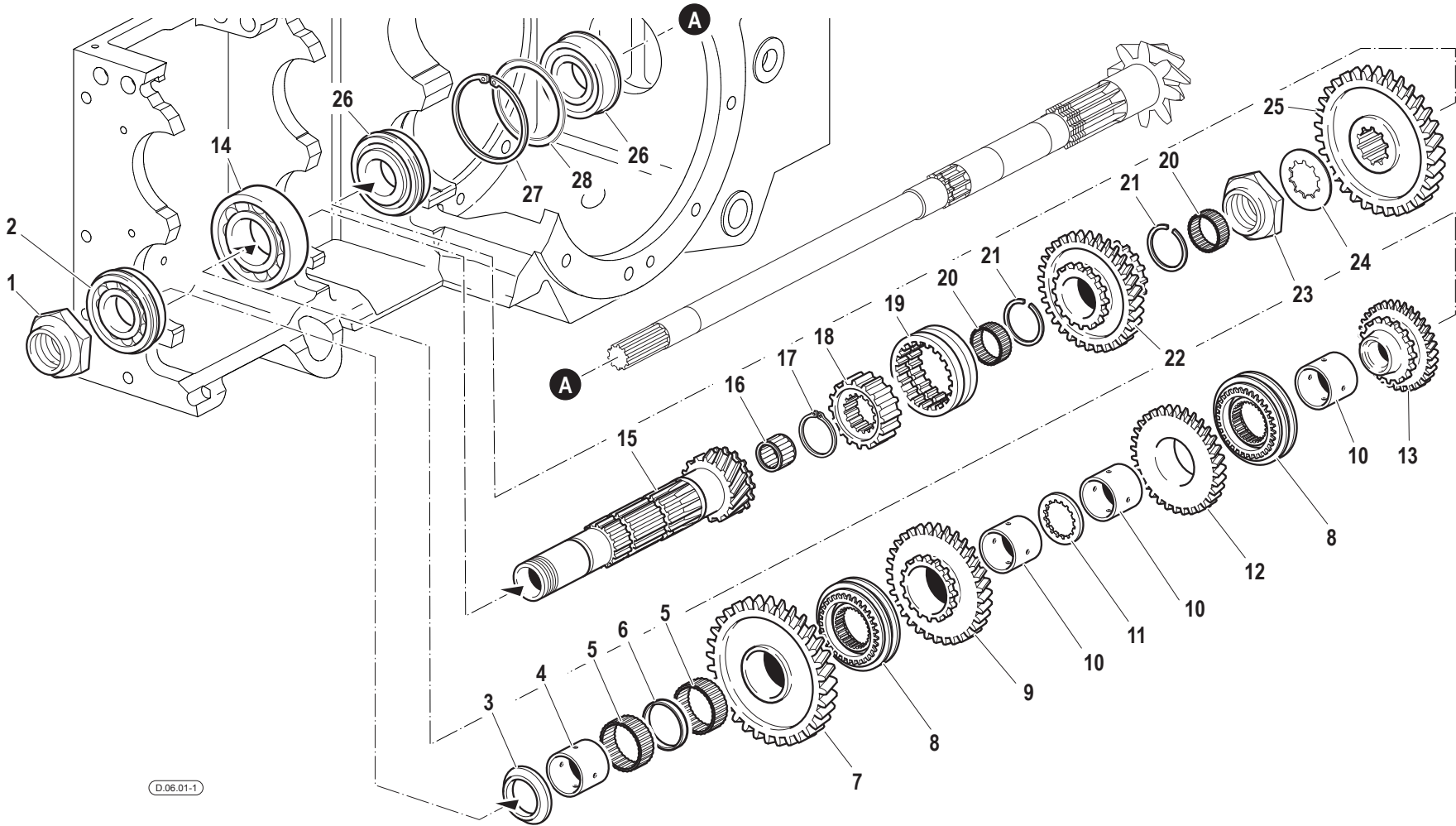

Pos.	Code	Q.ty	Description	Notes
1	56373840	1	RING NUT	
10	56470138	3	BUSHING	
11	56470137	1	SHIM	
12	52473836	1	DRIVEN GEAR	
13	52473837	1	DRIVEN GEAR	
14	F0812957000	1	BEARING 6210 (50/90/20)	
15	52474251	1	COUNTERSHAFT	
16	F0812692015	1	ROLLER CAGE K 25X35/25	
17	35121035	1	SEEGER RING E 35 DIN 471	
18	52470118	1	SLEEVE	
19	52470117	1	SLIDING SLEEVE	
2	F0812899000	1	BEARING 6208-NR	
20	F0812811000	2	ROLLER CAGE K 35X40/17	
21	F0801299100	2	SAFETY RING	
22	52478615	1	DOUBLE GEAR	
23	56378616	1	RING NUT	
24	56170760	1	RETAINING WASHER SP.1,0	
24	56174692	1	RETAINING WASHER SP.0,8	
24	56174693	1	RETAINING WASHER SP.0,9	
24	56174694	1	RETAINING WASHER SP.1,1	
24	56174695	1	RETAINING WASHER SP.1,2	
24	56175367	1	RETAINING WASHER SP.1,3	
25	52478617	1	GEAR	
26	37221320	2	BEARING	
27	35111080	1	SEEGER RING I 80 DIN 472	
28	56370089	1	RING	
28	56370127	1	RING	
28	56370128	1	RING	
28	56370830	1	RING	
3	52478611	1	SHIM	
4	56578610	1	BUSHING	
5	F0812951070	2	ROLLER CAGE K 47X52/17 H	
6	56278614	1	SPACER	
7	52478609	1	DRIVEN GEAR	

SERIAL

GEARS TRANSMISSION SHAFT / GEARS

Version: RS-M, RS-R, AR-M, AR-R

CODE REV

D.06.01_1_42932

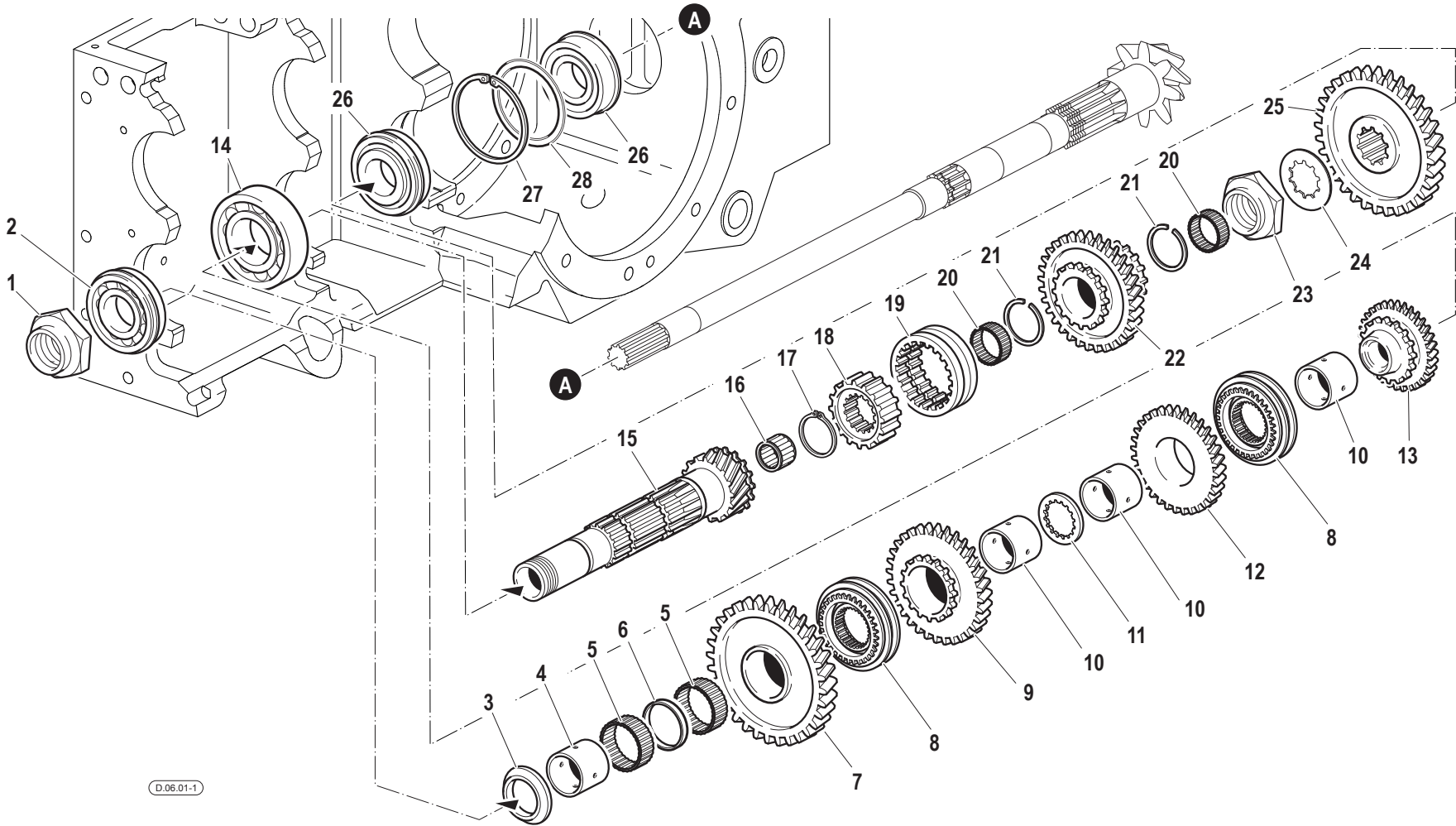

Pos.	Code	Q.ty	Description	Notes
8	58171139	2	LOCK SYNCHRONIZER	
9	52473835	1	DRIVEN GEAR	

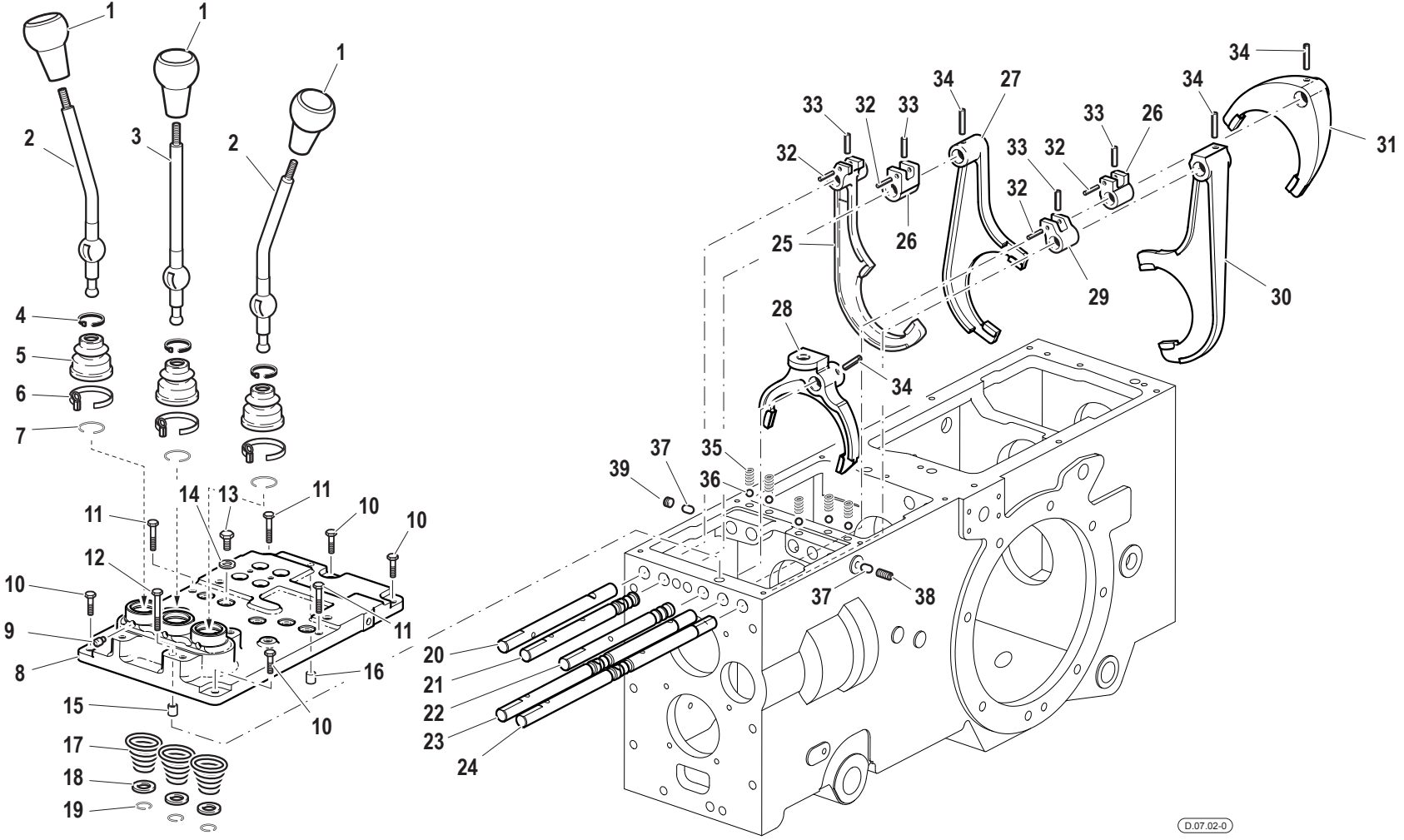

Pos.	Code	Q.ty	Description	Notes
1	58174192	3	HANDLE	
10	31112146	4	SCREW TE M8X22 UNI 5739 8G	
11	31112152	3	SCREW TE M8X30 UNI 5739 8G	
12	F0862944000	1	SCREW M8X60 UNI 5737	
13	56370186	5	PLUG	
14	F0843771000	5	COPPER WASHER 10,0x16/1	
15	56170017	1	PIN	
16	56570016	1	CYLINDRICAL PLUG	
17	58070164	3	SPRING	
18	56370172	3	SPACER	
19	58070168	3	LOCKRING	
2	52374189	2	COMMAND LEVER	
20	56371065	1	PULL ROD	
21	56370177	1	PULL ROD	
22	56370165	1	ROD	
23	56373213	1	PULL ROD	
24	56370154	1	PULL ROD	
25	52274299	1	SELECTOR FORK	
26	52375896	2	CATCH	
27	52272112	1	SELECTOR FORK	
28	52273364	1	SELECTOR FORK	
29	52375897	1	CATCH	
3	52374386	1	COMMAND LEVER	
30	51273893	1	SELECTOR FORK	
31	51270771	1	SELECTOR FORK	
32	F0851156000	4	PIN 4X30 DIN 1481 CL:C72	
33	F0851262000	4	PIN 6X26 DIN 7343 CL:C72	
34	F0851267050	3	PIN 6X30 DIN 7343 CL:C72	
35	58070741	5	SPRING	
36	F0847434000	5	BALL	
37	56570125	2	TOGGLE	
38	F0863183000	1	SCREW M10X16 UNI 5923	
39	F0852578060	1	CONICAL PLUG	
4	F0817640003	3	CLAMP 4,8x180	

SERIAL

GEARBOX CONTROLS

CODE REV

D.07.02_0_39660

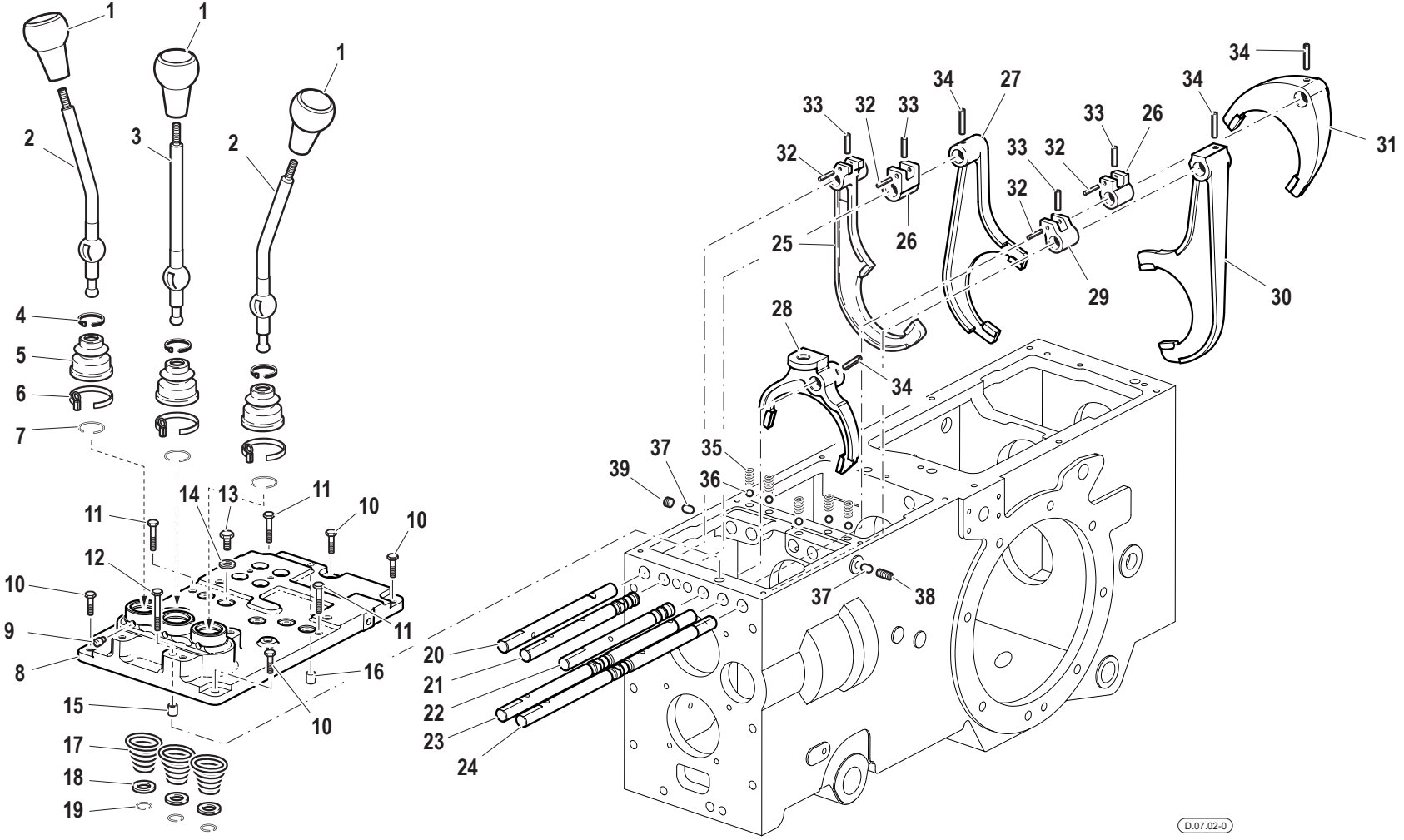

Pos.	Code	Q.ty	Description	Notes
5	55170053	3	CAP	
6	58170054	3	COLLAR	
7	58070169	3	LOCKRING	
8	51174394	1	COVER	
9	56370018	6	HINGE PIN	

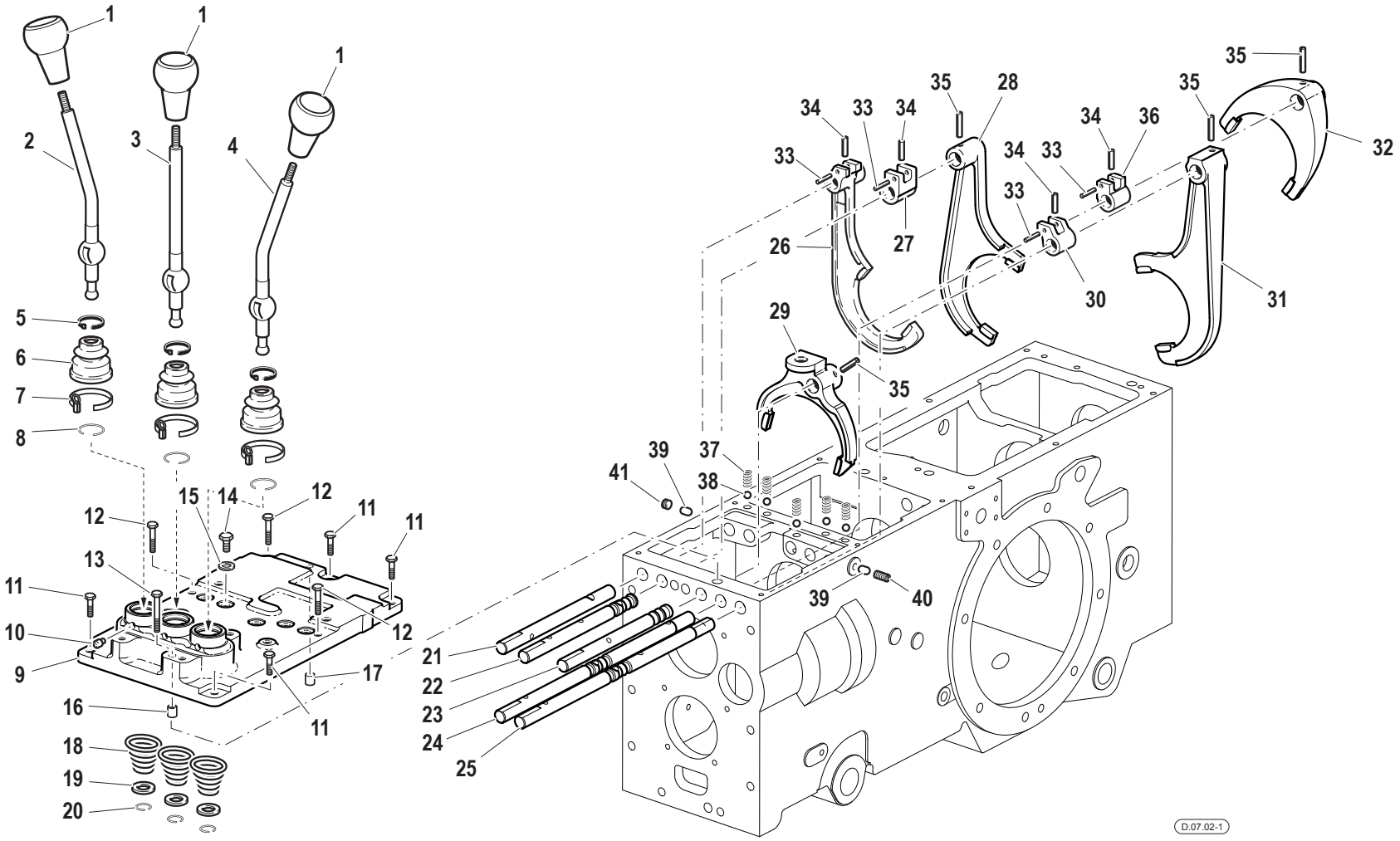

Pos.	Code	Q.ty	Description	Notes
1	58174192	3	HANDLE	
10	56370018	6	HINGE PIN	
11	31112146	4	SCREW TE M8X22 UNI 5739 8G	
12	31112152	3	SCREW TE M8X30 UNI 5739 8G	
13	F0862944000	1	SCREW M8X60 UNI 5737	
14	56370186	5	PLUG	
15	F0843771000	5	COPPER WASHER 10,0x16/1	
16	56170017	1	PIN	
17	56570016	1	CYLINDRICAL PLUG	
18	58070164	3	SPRING	
19	56370172	3	SPACER	
2	52374189	1	COMMAND LEVER	
20	58070168	3	LOCKRING	
21	56371065	1	PULL ROD	
22	56370177	1	PULL ROD	
23	56370165	1	ROD	
24	56378622	1	PULL ROD	
25	56378630	1	PULL ROD	
26	52274299	1	SELECTOR FORK	
27	52375896	1	CATCH	
28	52272112	1	SELECTOR FORK	
29	52273364	1	SELECTOR FORK	
3	52374386	1	COMMAND LEVER	
30	52378629	1	CATCH	
31	51278623	1	SELECTOR FORK	
32	51270771	1	SELECTOR FORK	
33	F0851156000	4	PIN 4X30 DIN 1481 CL:C72	
34	F0851262000	4	PIN 6X26 DIN 7343 CL:C72	
35	F0851267050	3	PIN 6X30 DIN 7343 CL:C72	
36	52378628	1	CATCH	
37	58070741	5	SPRING	
38	F0847434000	5	BALL	
39	56570125	2	TOGGLE	
4	52378636	1	COMMAND LEVER	

SERIAL

913987

GEARBOX CONTROLS

CODE REV

D.07.02_1_39700

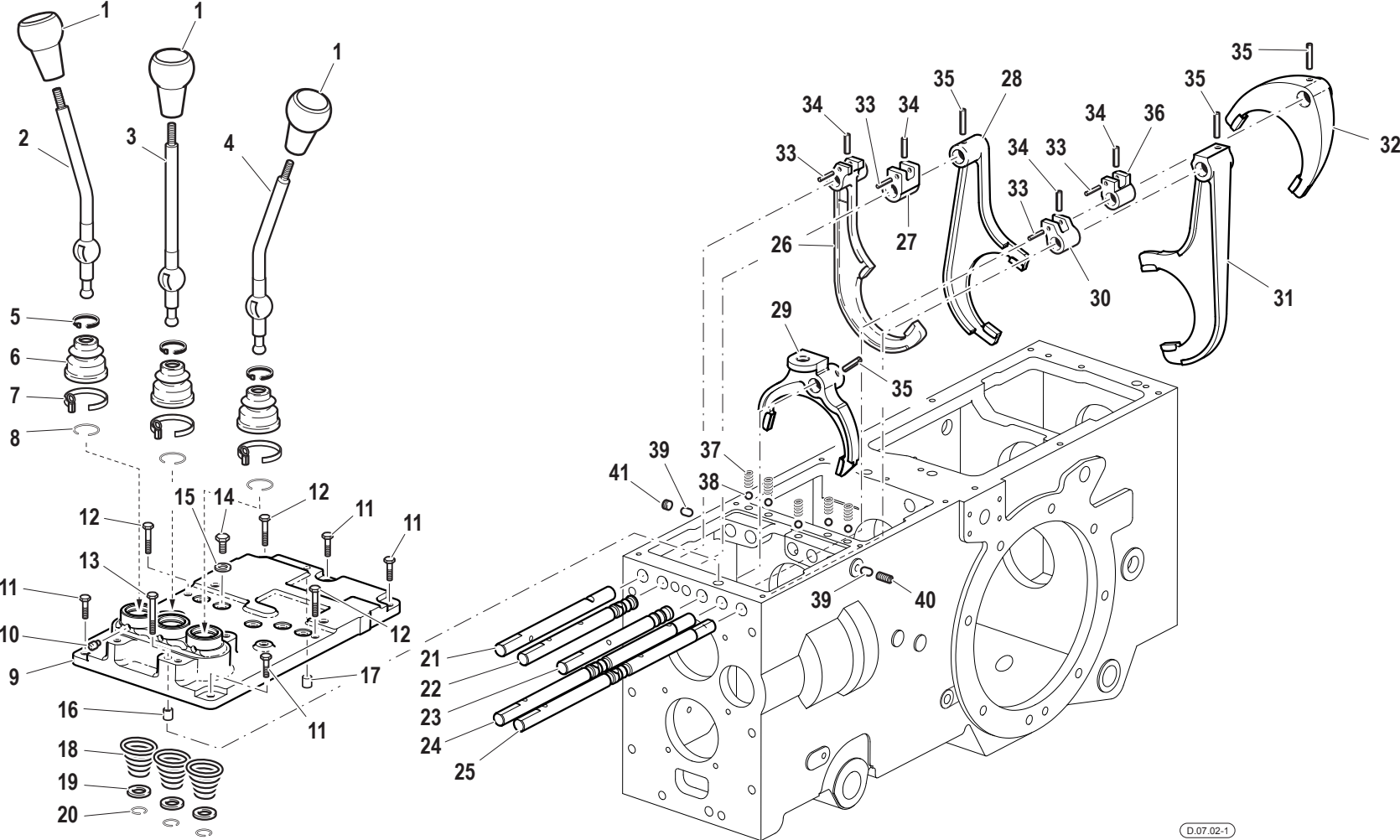

Pos.	Code	Q.ty	Description	Notes
40	F0863183000	1	SCREW M10X16 UNI 5923	
41	F0852578060	1	CONICAL PLUG	
5	F0817640003	3	CLAMP 4,8x180	
6	55170053	3	CAP	
7	58170054	3	COLLAR	
8	58070169	3	LOCKRING	
9	51179545	1	COVER	

SERIAL

913987

GEARBOX CONTROLS

CODE REV

D.07.02_1_39700

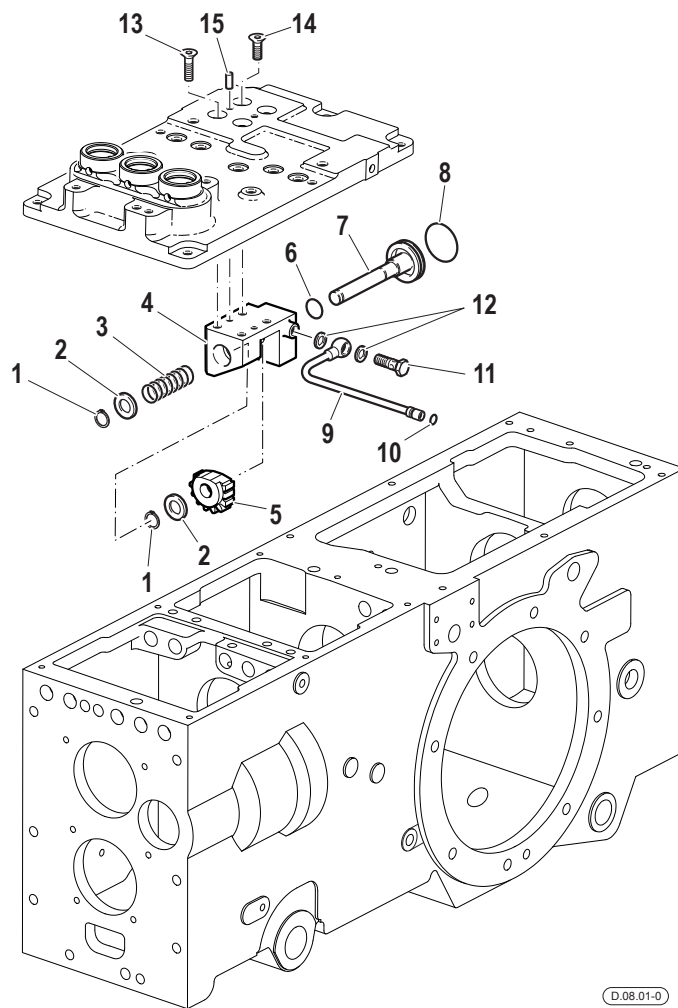

Pos.	Code	Q.ty	Description	Notes
1	35121014	2	SEEGER RING E 14 DIN 471	
10	F0803050000	1	O-RING 2025	
11	F0843102000	1	THR. TERMINAL END M10X1,25X20	
12	F0843771000	2	COPPER WASHER 10,0x16/1	
13	F0862655000	2	SCREW M8X25-5933	
14	F0862549000	2	SCREW M8X18 UNI 5933	
15	52074435	2	CYLINDRICAL PLUG	
2	F0843957000	2	WASHER D.25x14,5/2,2	
3	58072107	1	SPRING	
4	59074438	1	SMALL BLOCK	
5	56475839	1	SMALL BLOCK	
6	F0803186000	1	O-RING 123	
7	59272073	1	PISTON	
8	38114070	1	O-RING	
9	59074436	1	PIPE	

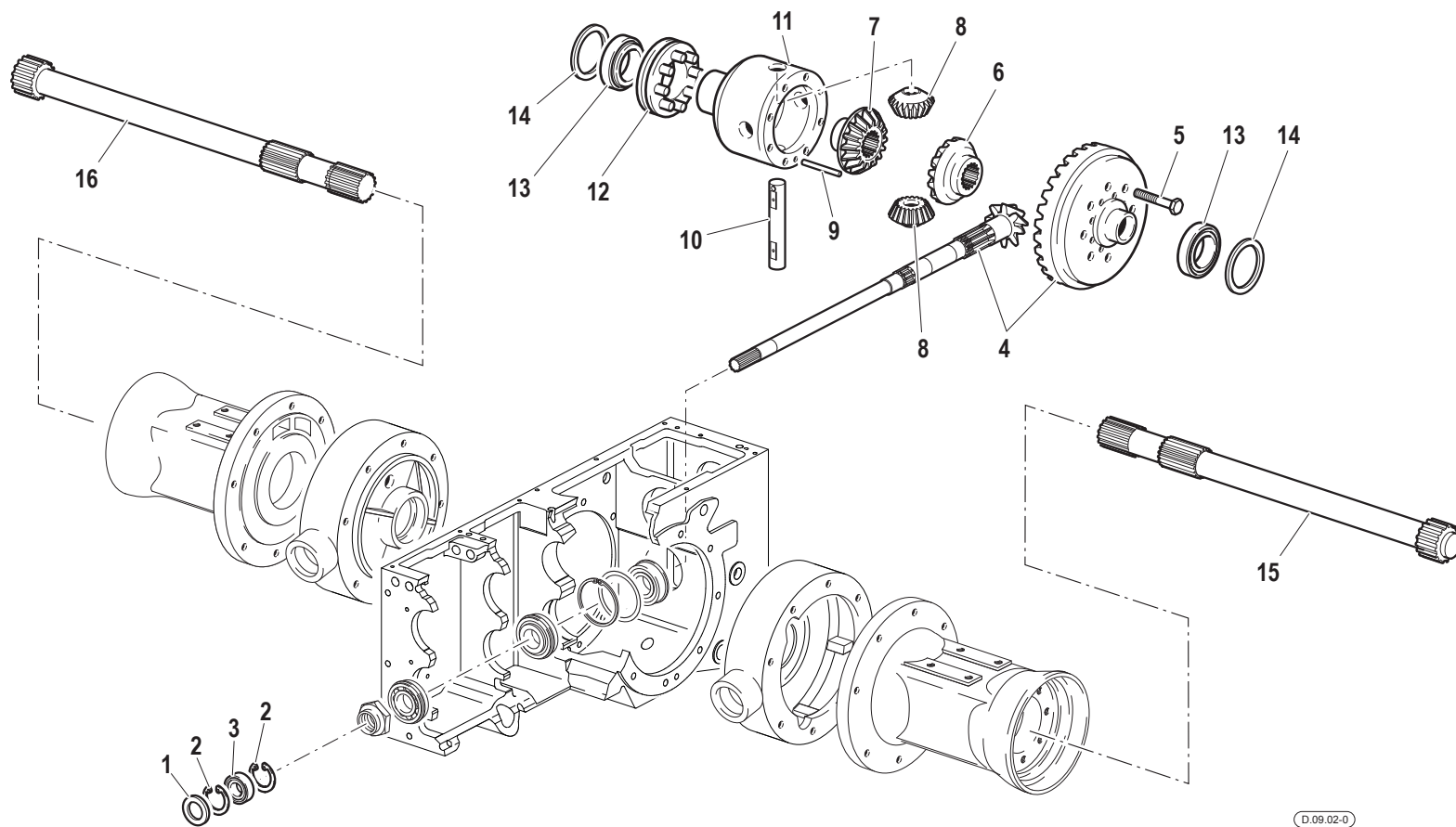

Pos.	Code	Q.ty	Description	Notes
1	F0802104000	1	OIL SEAL 25x62/10	
10	56471036	1	PIN	
11	51371035	1	HOUSING	
12	59070065	1	SLEEVE	
13	F0812956000	2	BEARING 32010 X/Q	
14	56370089	1	RING	
14	56370127	1	RING	
14	56370128	1	RING	
14	56370830	1	RING	
15	56470814	1	REAR AXLE SHAFT	
16	56470815	1	REAR AXLE SHAFT	
2	35111062	2	SEEGER RING I 62 DIN 472	
3	37111254	1	BEARING	
4	59378814	1	BEVEL GEAR	
5	F0863311250	8	SCREW M10x1,5x32	
6	52470062	1	PINION	
7	52470061	1	PINION	
8	52470067	2	DIFFERENTIAL PINION	
9	56371037	1	PIN	

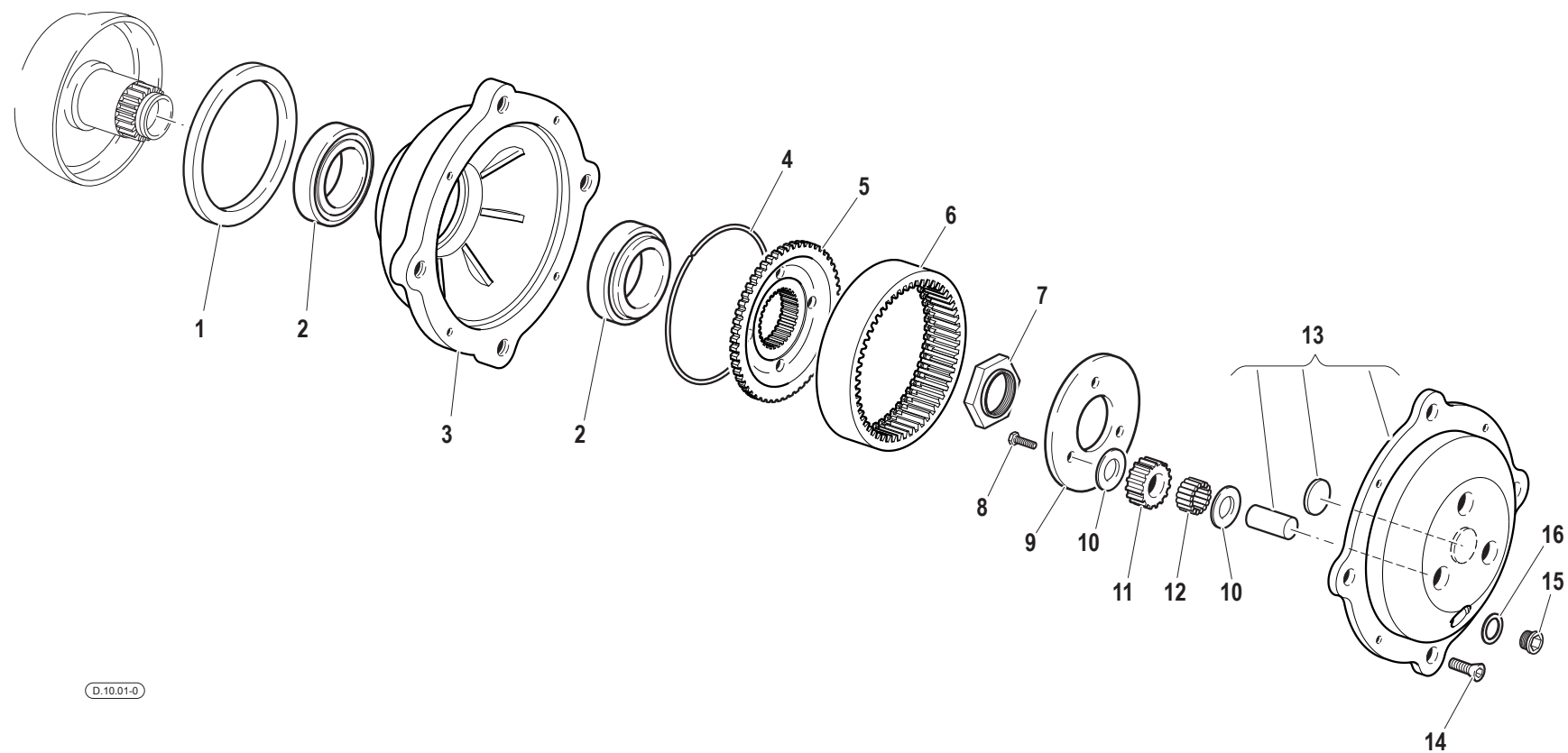

D.10.01-0

Pos.	Code	Q.ty	Description	Notes
1	F0802700150	1	SEAL 125x150x12	
10	56370076	6	SHIM	
11	52470087	3	PLANETARY GEAR	
12	58170070	3	ROLLER BEARING	
13	59070094	1	COVER	
14	F0862655000	4	SCREW M8X25-5933	
15	56370081	1	PLUG	
16	F0844273090	1	GASKET 22X28X1,5 CU 99,5	
2	F0812975250	2	CYL. ROLLER BEARING 32013X	
3	51172005	1	HUB	
4	58070071	1	RING	
5	52370075	1	FLANGE	
6	52370072	1	CROWN WHEEL	
7	56370079	1	RING NUT	
8	F0862478070	3	SCREW M8x16	
9	56170074	1	ADJUSTING RING	

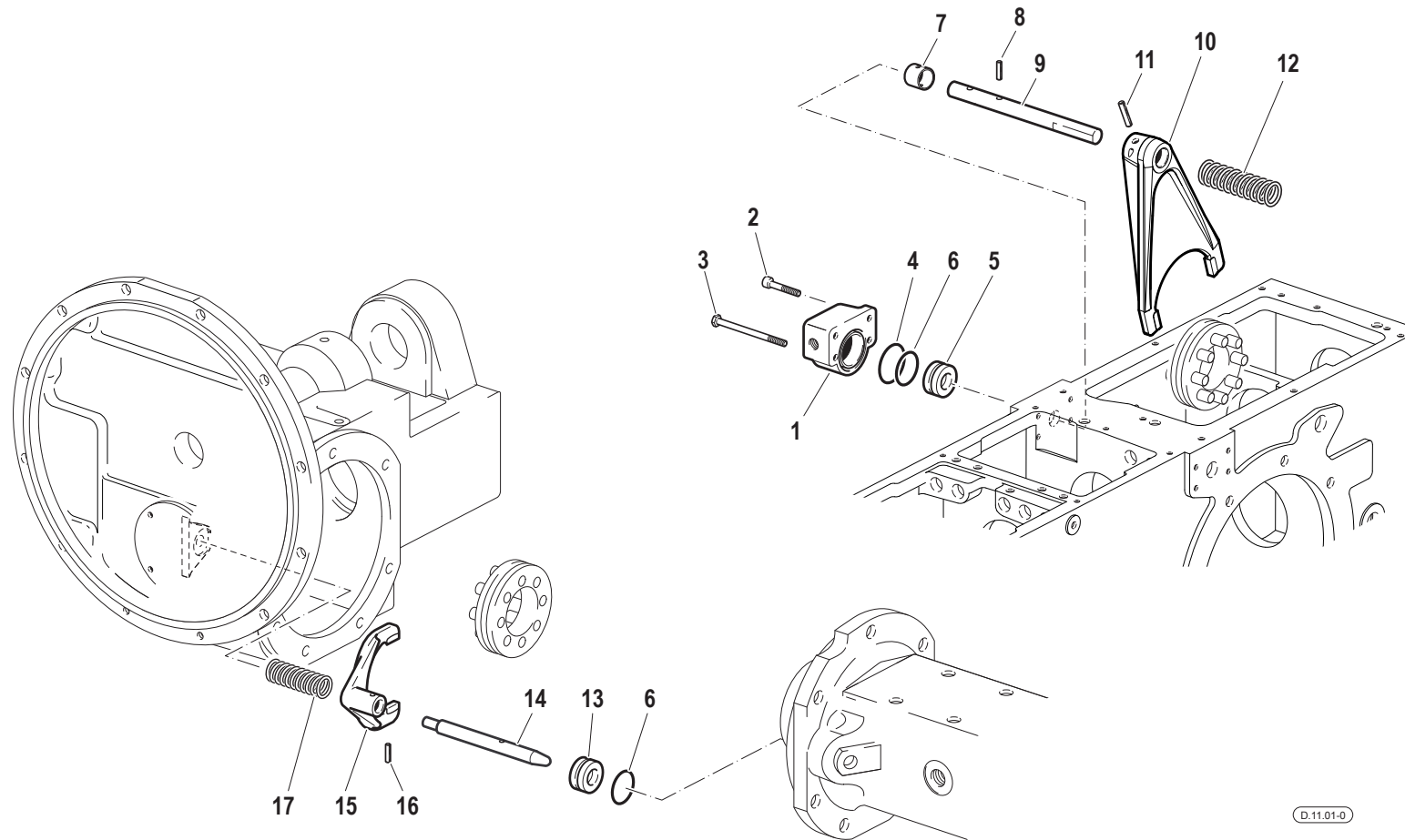

Pos.	Code	Q.ty	Description	Notes
1	52374641	1	SMALL BLOCK	
10	51278573	1	FORK	
11	F0851267050	1	PIN 6X30 DIN 7343 CL:C72	
12	58070198	1	SPRING	
13	56370583	1	PISTON	
14	56370582	1	LOCKING DEVICE	
15	51270203	1	FORK	
16	F0851260000	1	PIN 6X24 DIN 1481	
17	58070205	1	SPRING	
2	31152085	2	SCREW TCEI M8X25 UNI 5931	
3	31112161	2	SCREW TE M8X50 UNI 5737 8G	
4	F0803209000	1	O-RING 3156	
5	56370187	1	PISTON	
6	58170195	2	GASKET	
7	56176127	1	BUSHING	
8	34213054	1	ROLL PIN	
9	56376256	1	LOCKING DEVICE	

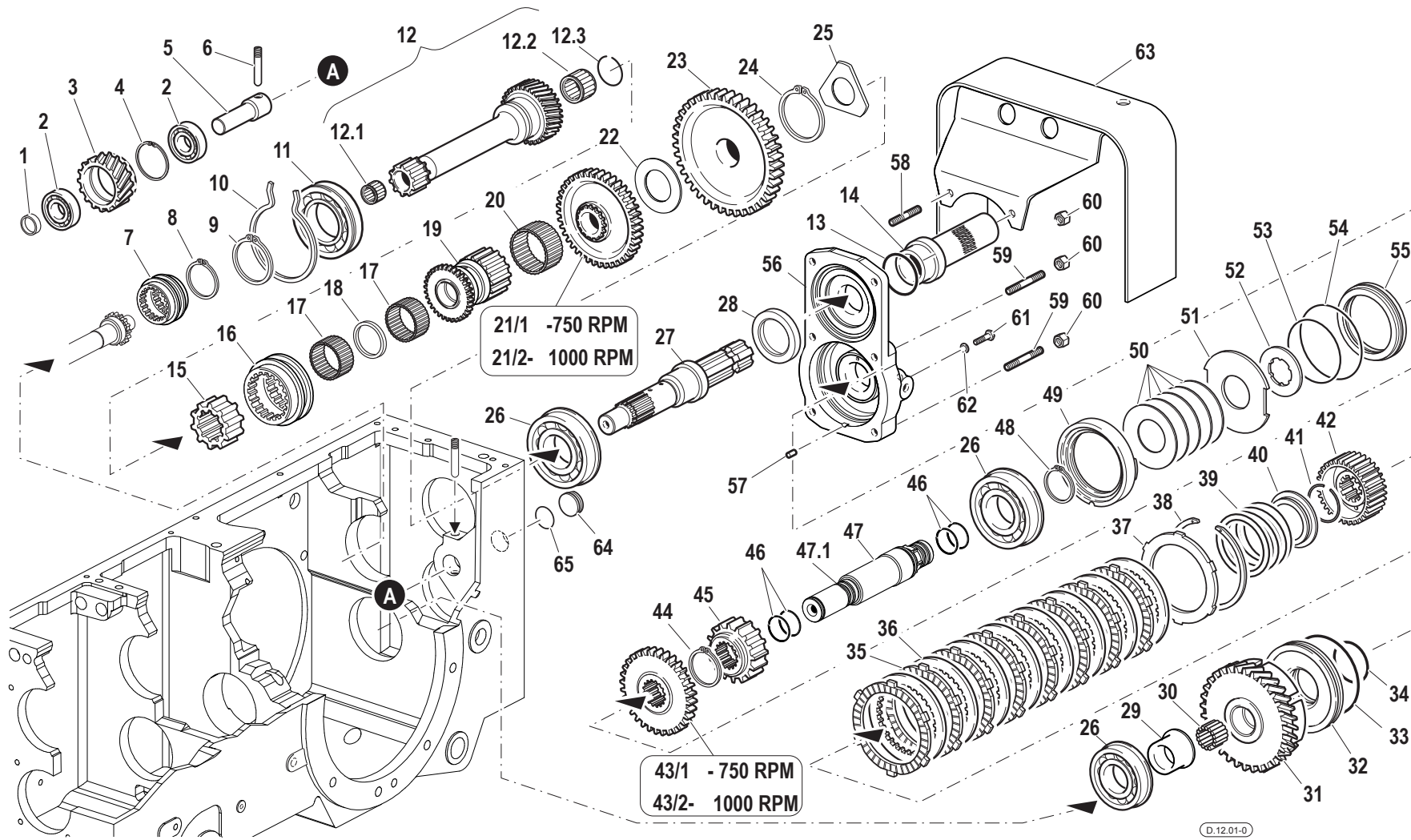

Pos.	Code	Q.ty	Description	Notes
1	56171572	1	SPACER	
10	58170130	1	CIRCLIP	
11	F0812957010	1	BEARING 6210-N (50/90/20)	
12	59900376	1	PTO SHAFT	
12.1	F0812599086	1	BUSHING HK1816	
12.2	F0812689050	1	ROLLER CAGE K 25X33/20	
12.3	F0801248000	1	SAFETY RING	
13	P47043300000	1	PROTECTIVE RING	
14	P47033000000	1	GUARD	
15	52476068	1	SLEEVE	
16	52476062	1	SHIFTING CLAW	
17	F0812784000	2	ROLLER CAGE K 32X37/27 H	
18	56076074	1	SPACER	
19	52476067	1	SLEEVE	
2	F0812637000	2	BEARING 6204 (20x47x14)	
20	F0812951300	1	ROLLER CAGE K 50X55/27 H	
21/1	52476065	1	DRIVEN GEAR	
21/2	52476066	1	DRIVEN GEAR	
22	56475568	1	SHIM	
23	52475991	1	DRIVEN GEAR	
24	F0801244080	2	SEEGER RING E 32X2 UNI 7436	
25	56476073	1	SHIM	
26	F0812918010	3	BEARING 6308-NR (40x90x23)	
27	52475560	1	PTO SHAFT	
28	F0802228005	1	SEAL 48x65/10	
29	56470987	1	BUSHING	
3	52476868	1	INTERMEDIATE WHEEL	
30	F0812736010	1	ROLLER CAGE K 30X35/20 H	
31	59376075	1	CLUTCH HOUSING	
32	53273886	1	PISTON	
33	58172400	1	GASKET	
34	58172402	1	GASKET	
35	58172447	8	DISC	
36	58172448	8	DISC	

SERIAL

POWER TAKE-OFF

CODE REV

D.12.01_0_40202

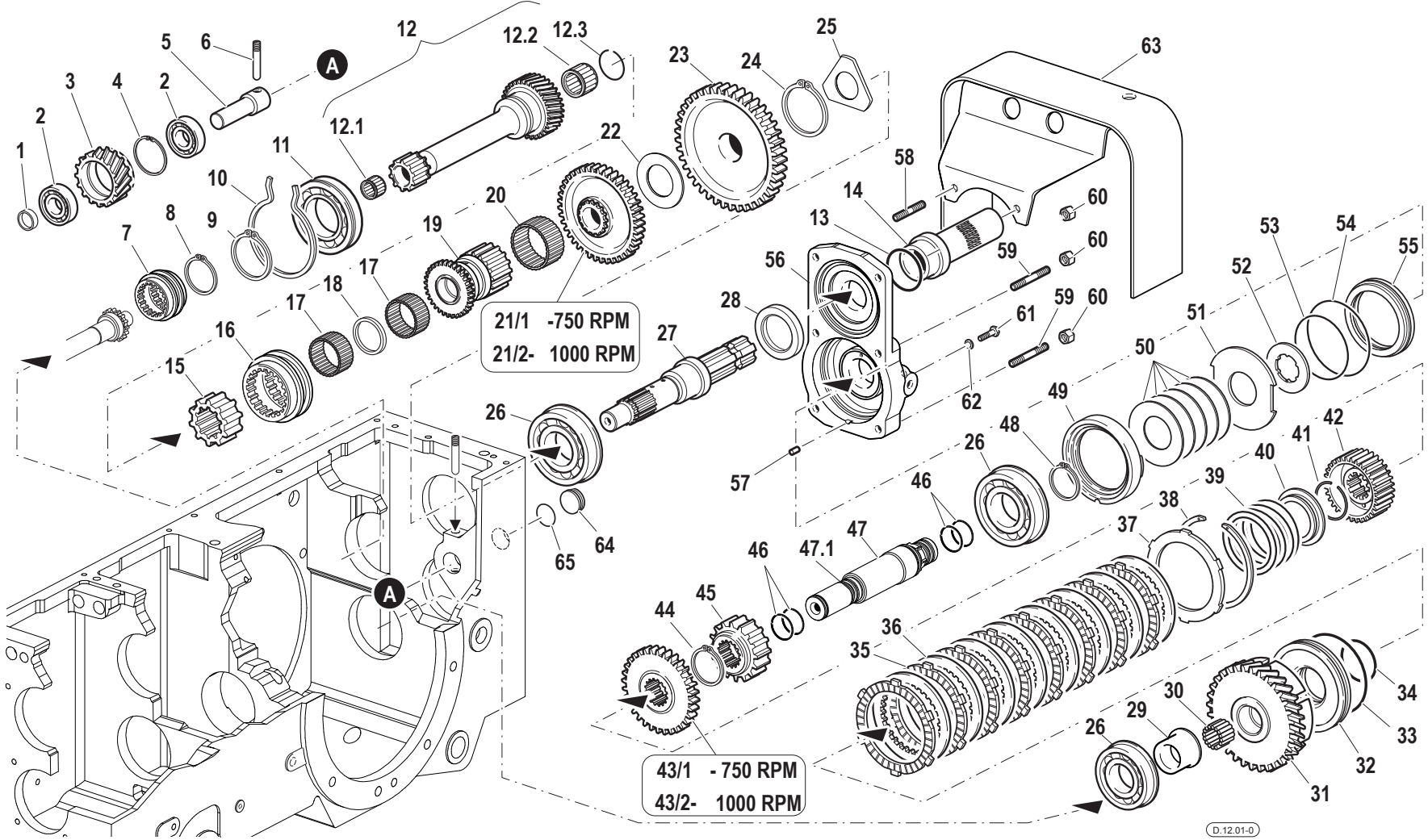

Pos.	Code	Q.ty	Description	Notes
37	52372292	1	RING	
38	58072389	1	CIRCLIP	
39	58074092	1	RESTORING SPRING	
4	35111047	1	SEEGER RING I 47 DIN 472	
40	56372282	1	RING	
41	58072399	1	SAFETY RING	
42	52475565	1	DISC HUB	
43/1	52475994	1	GEAR	
43/2	52475996	1	GEAR	
44	F0801282050	1	SEEGER RING E38 UNI 7436	
45	52475992	1	GEAR	
46	58072398	4	SEAL	
47	59276076	1	SHAFT	
48	F0801297050	1	SEEGER RING E 40x2,5 U/7436	
49	56475516	1	SPACER	
5	56174108	1	GEAR PIN	
50	59978093	1	KIT	
51	56475517	1	BRAKE DISC	
51	56475757	1	BRAKE DISC	
51	56473890	1	BRAKE DISC	
51	56474713	1	BRAKE DISC	
51	56475398	1	BRAKE DISC	
51	56475416	1	BRAKE DISC	
51	56475417	1	BRAKE DISC	
52	56475844	1	CLUTCH DISC	
53	38116317	1	RING	
54	38118720	1	O-RING	
55	53273891	1	PISTON	
56	59377433	1	COVER	
57	F0851226000	1	PIN 6X12 UNI 1707 CL:C20	
58	F0838154010	2	STUD BOLT M8X25 UNI 5911 8.8	
59	31312089	4	STUD BOLT M8x52x14x18	
6	56370178	1	SCREW	
60	31211080	6	NUT M8	

SERIAL

POWER TAKE-OFF

CODE REV

D.12.01_0_40202

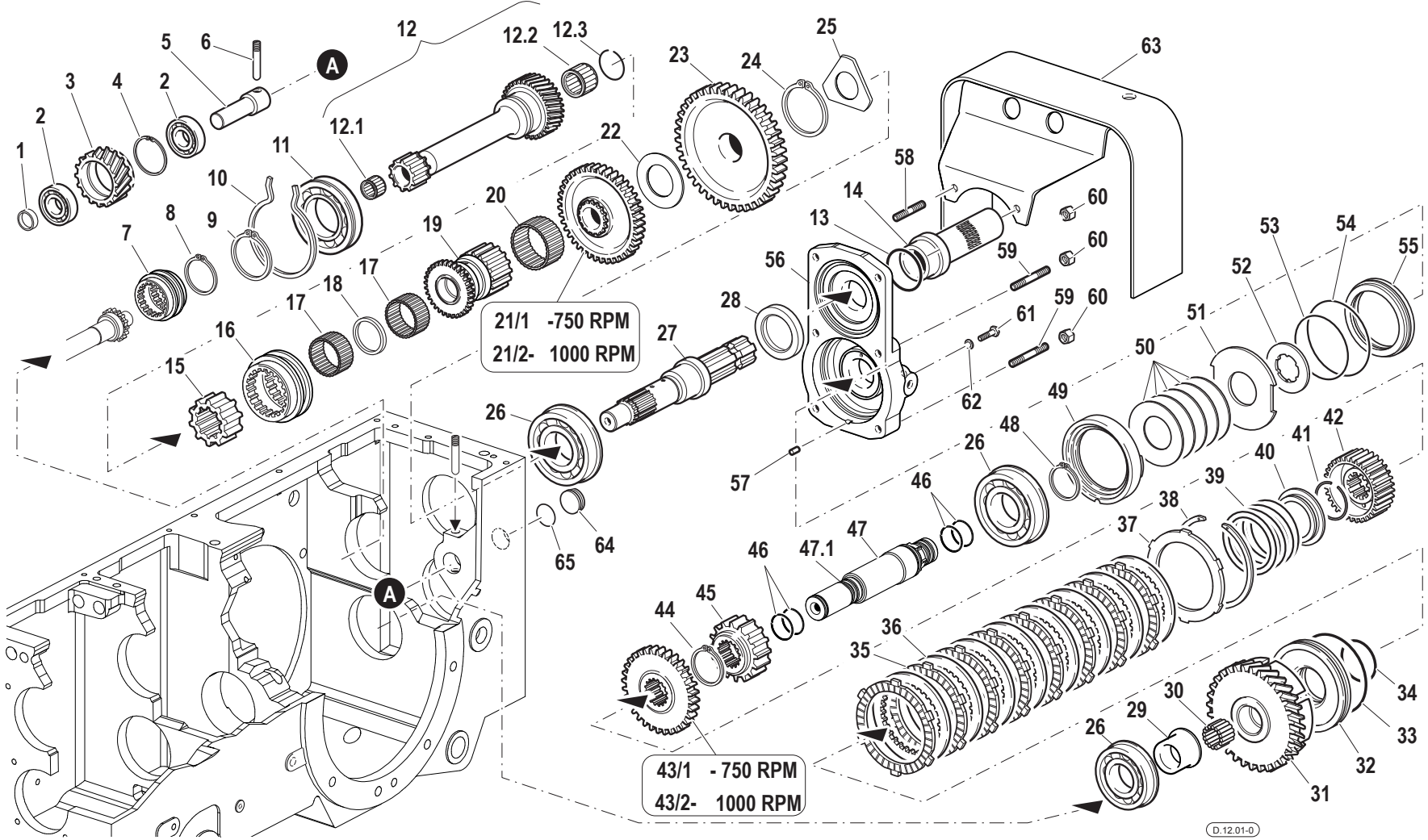

Pos.	Code	Q.ty	Description	Notes
61	F0862448100	1	SCREW M8X10 UNI 5740	
62	F0843641000	1	COPPER WASHER 8x14/1,5	
63	59074993	1	P.T.O. PROTECTION	
64	56074313	1	PLUG	
65	F0803199010	1	O-RING 132 (23,81X2,62)	
7	52470298	1	SLEEVE	
8	35121040	1	SEEGER RING E 40 DIN 471	
9	F0801353000	1	SEEGER RING E 50 UNI 7435	

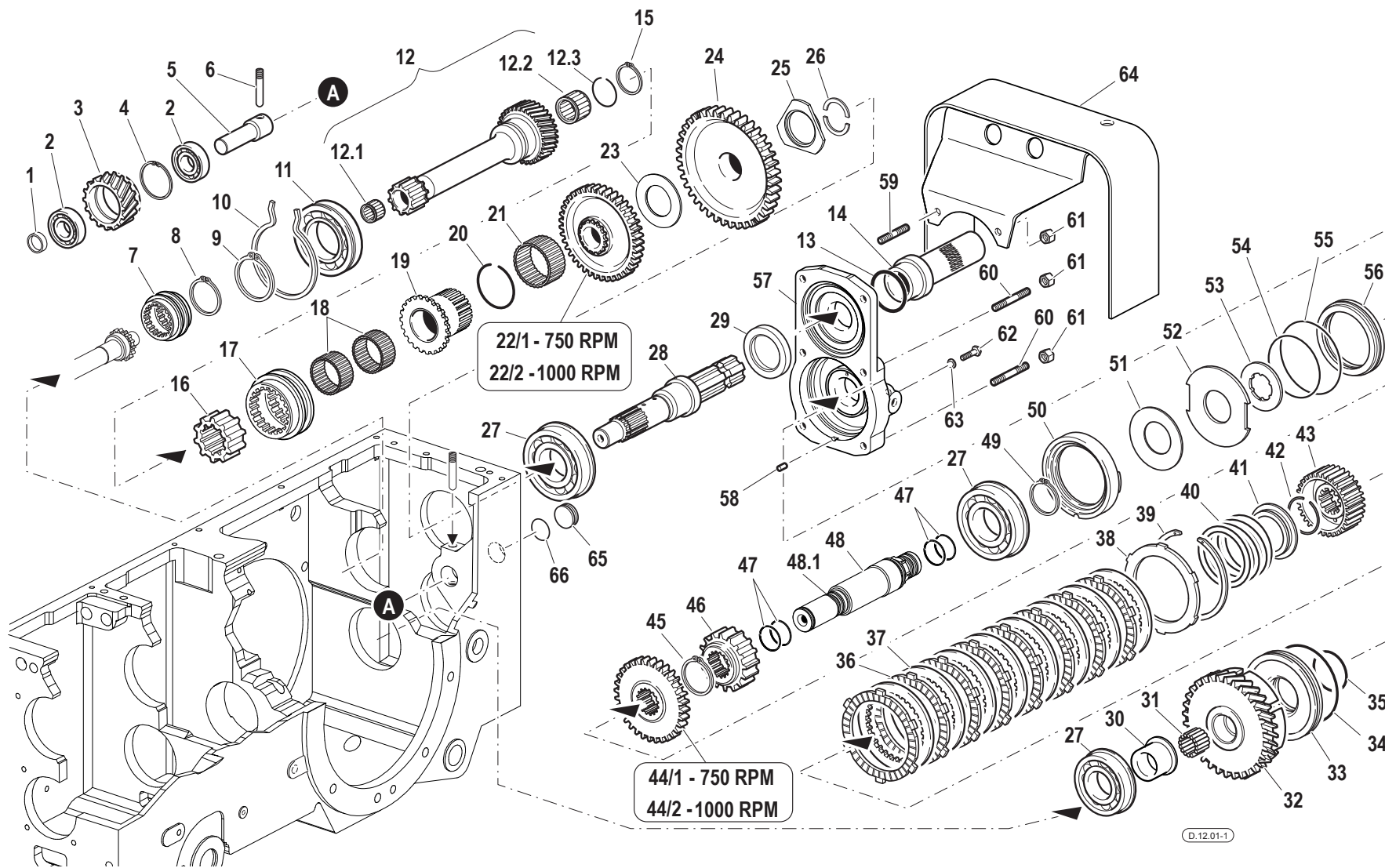

Pos.	Code	Q.ty	Description	Notes
1	56171572	1	SPACER	
10	58170130	1	CIRCLIP	
11	F0812957010	1	BEARING 6210-N (50/90/20)	
12	59900376	1	PTO SHAFT	
12.1	F0812599086	1	BUSHING HK1816	
12.2	F0812689050	1	ROLLER CAGE K 25X33/20	
12.3	F0801248000	1	SAFETY RING	
13	P47043300000	1	PROTECTIVE RING	
14	P47033000000	1	GUARD	
15	F0801241010	1	SEEGER RING E 30 UNI 7436	
16	52476068	1	SLEEVE	
17	52476062	1	SHIFTING CLAW	
18	F0812784000	2	ROLLER CAGE K 32X37/27 H	
19	52478568	1	SHIFTING CLAW	
2	F0812637000	2	BEARING 6204 (20x47x14)	
20	37931413	1	SAFETY RING	
21	F0812951300	1	ROLLER CAGE K 50X55/27 H	
22/1	52476065	1	DRIVEN GEAR	
22/2	52476066	1	DRIVEN GEAR	
23	56475568	1	SHIM	
24	52475991	1	DRIVEN GEAR	
25	56478567	1	SHIM	
26	56378566	2	HALF RING	
27	F0812918010	3	BEARING 6308-NR (40x90x23)	
28	52478565	1	PTO SHAFT	
29	F0802228005	1	SEAL 48x65/10	
3	52476868	1	INTERMEDIATE WHEEL	
30	56470987	1	BUSHING	
31	F0812736010	1	ROLLER CAGE K 30X35/20 H	
32	52475562	1	CLUTCH HOUSING	
33	53273886	1	PISTON	
34	58172400	1	GASKET	
35	58172402	1	GASKET	
36	58172447	8	DISC	

SERIAL

911149

POWER TAKE-OFF

CODE REV

D.12.01_1_40279

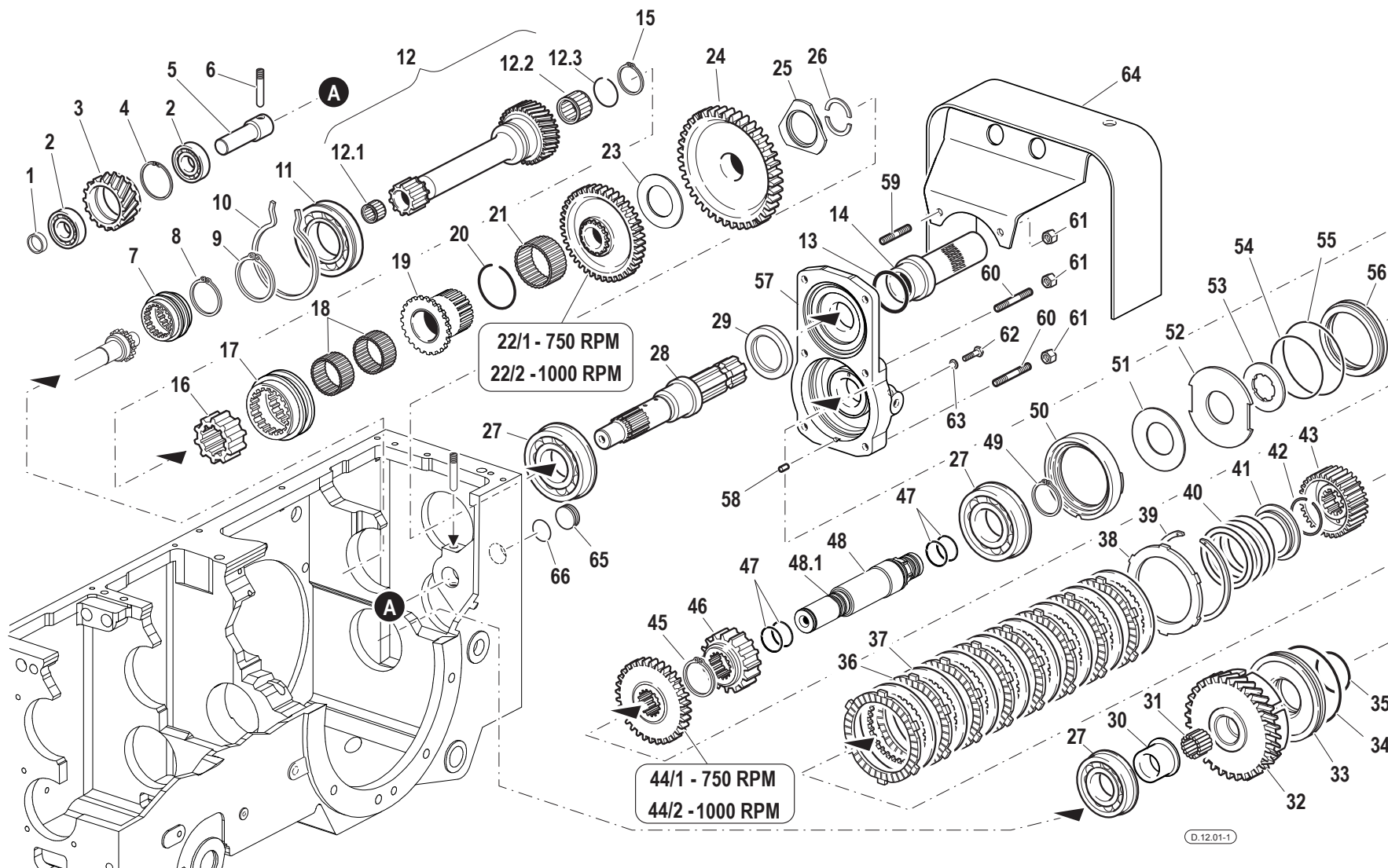

Pos.	Code	Q.ty	Description	Notes
37	58172448	8	DISC	
38	52372292	1	RING	
39	58072389	1	CIRCLIP	
4	35111047	1	SEEGER RING I 47 DIN 472	
40	58074092	1	RESTORING SPRING	
41	56372282	1	RING	
42	58072399	1	SAFETY RING	
43	52475565	1	DISC HUB	
44/1	52475994	1	GEAR	
44/2	52475996	1	GEAR	
45	F0801282050	1	SEEGER RING E38 UNI 7436	
46	52475992	1	GEAR	
47	58072398	4	SEAL	
48	59276076	1	SHAFT	
48.1	F0852578060	2	CONICAL PLUG	
49	F0801297050	1	SEEGER RING E 40x2,5 U/7436	
5	56174108	1	GEAR PIN	
50	56475516	1	SPACER	
51	58073889	1	CUP SPRING	
52	56475517	1	BRAKE DISC	
52	56475518	1	CLUTCH DISC	
52	56473890	1	BRAKE DISC	
52	56474713	1	BRAKE DISC	
52	56474714	1	BRAKE DISC	
53	56475844	1	CLUTCH DISC	
54	38116317	1	RING	
55	38118720	1	O-RING	
56	53273891	1	PISTON	
57	59377433	1	COVER	
58	F0851226000	1	PIN 6X12 UNI 1707 CL:C20	
59	F0838154010	2	STUD BOLT M8X25 UNI 5911 8.8	
6	56370178	1	SCREW	
60	31312089	4	STUD BOLT M8x52x14x18	
61	31211080	6	NUT M8	

SERIAL

911149

POWER TAKE-OFF

CODE REV

D.12.01_1_40279

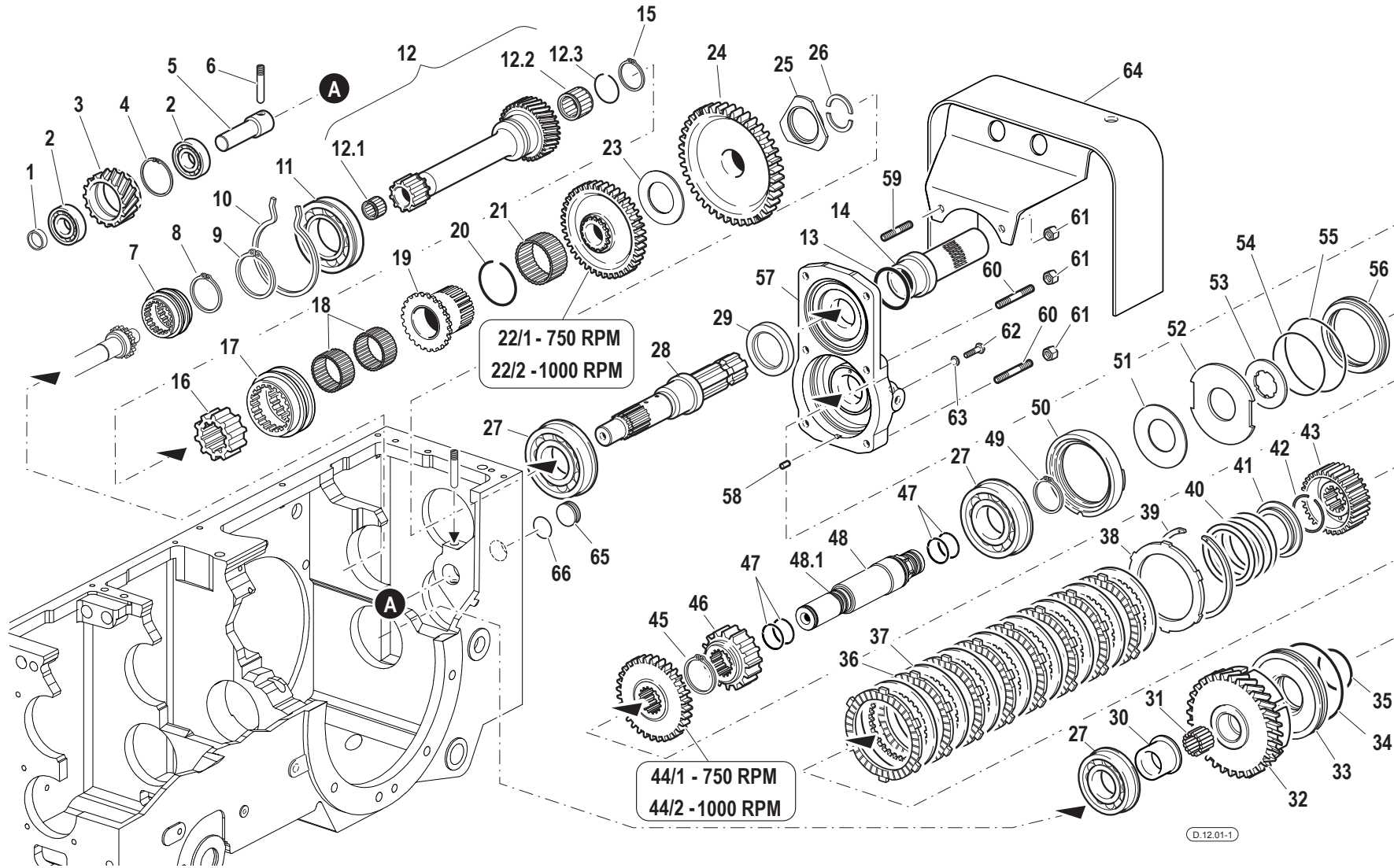

Pos.	Code	Q.ty	Description	Notes
62	F0862448100	1	SCREW M8X10 UNI 5740	
63	F0843641000	1	COPPER WASHER 8x14/1,5	
64	59074993	1	P.T.O. PROTECTION	
65	56074313	1	PLUG	
66	F0803199010	1	O-RING 132 (23,81X2,62)	
7	52470298	1	SLEEVE	
8	35121040	1	SEEGER RING E 40 DIN 471	
9	F0801353000	1	SEEGER RING E 50 UNI 7435	

SERIAL

911149

POWER TAKE-OFF

CODE REV

D.12.01_1_40279

POWER TAKE-OFF CONTROLS

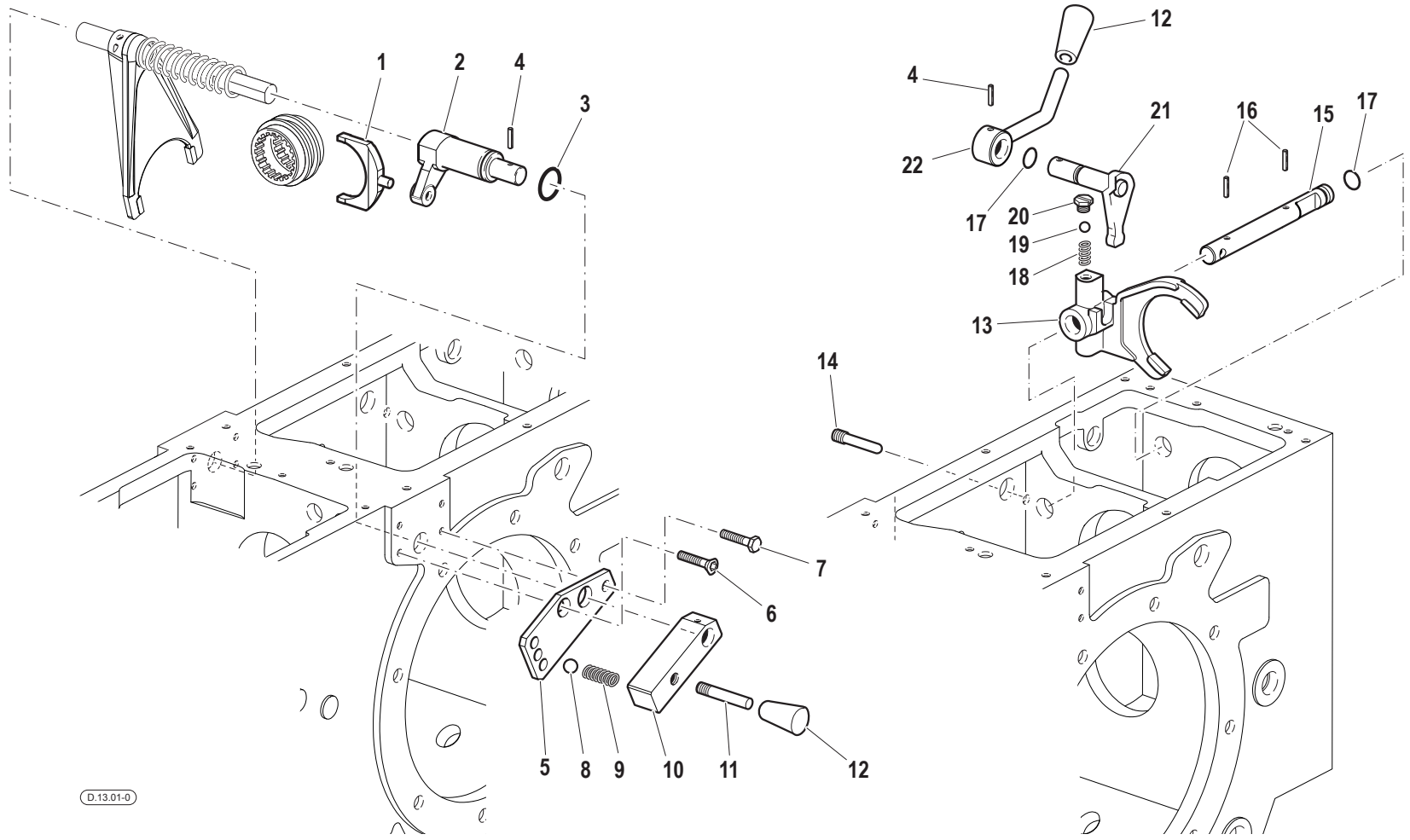

D.13.01-0

Pos.	Code	Q.ty	Description	Notes
1	56470299	1	SELECTOR FORK	
10	56174431	1	LEVER	
11	56170447	1	TIP	
12	F0828468050	2	GRIP	
13	51275570	1	SELECTOR FORK	
14	56370178	1	SCREW	
15	56375571	1	ROD	
16	F0851180000	2	PIN 5X26 DIN 1481 CL:C72	
17	38111078	2	O-RING 3043 (10,78X2,62)	
18	58070741	2	SPRING	
19	F0847434000	2	BALL	
2	52370152	1	LEVER	
20	56076055	1	PLUG	
21	59075572	1	LEVER	
22	59078865	1	LEVER	
3	38112200	1	O-RING 3087 (22,00X2,62)	
4	34211054	1	ROLL PIN	
5	56374430	1	PLATE	
6	31132566	1	SCREW TSVEI M8X20 UNI 5933	
7	31112150	1	SCREW TE M8X20 UNI 5739 8G	
8	F0847462000	1	BALL RB-11.112	
9	F0831047000	1	SPRING	

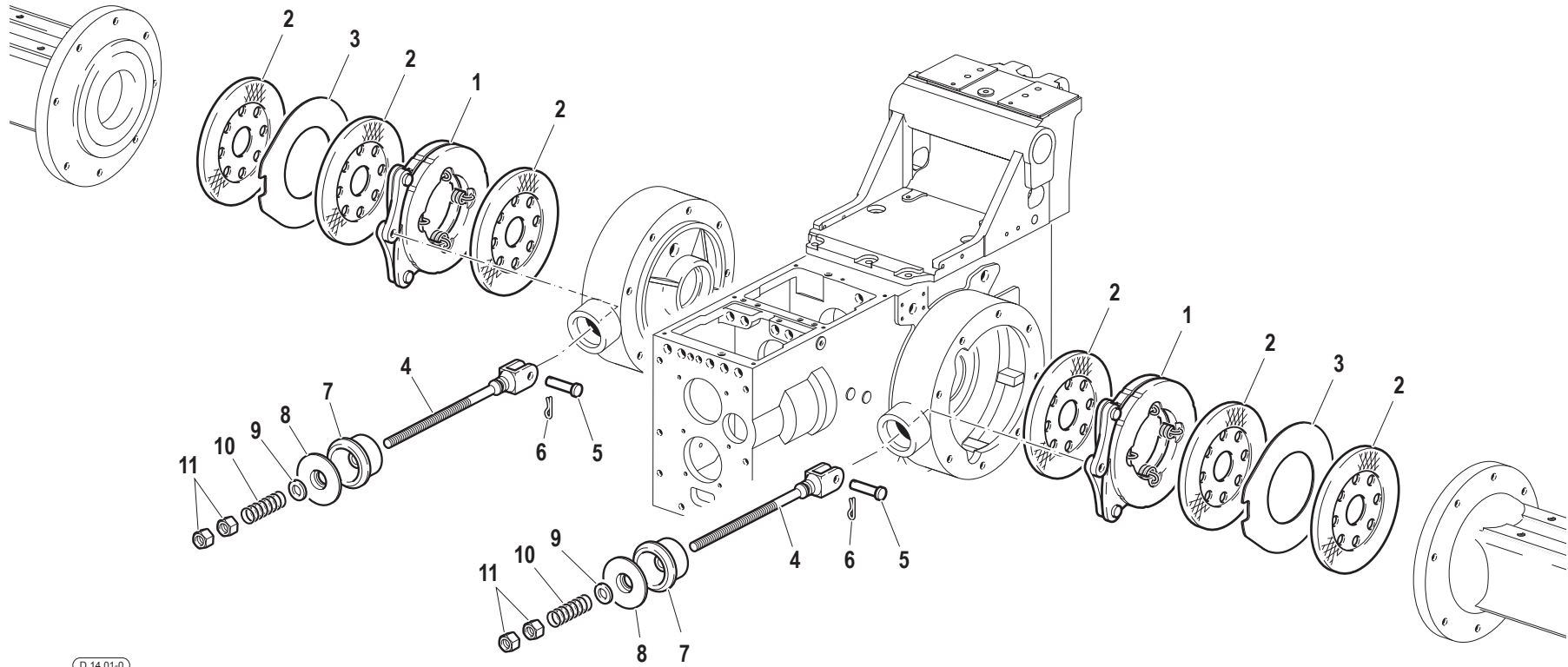

Pos.	Code	Q.ty	Description	Notes
1	58170045	2	BRAKE	
10	58070366	2	RETAINING SPRING	
11	31231120	4	NUT M12	
2	58170703	6	BRAKE DISC	
3	58171019	2	SHIM	
4	56370038	2	ROD	
5	56470231	2	PIN	
6	F0810510000	2	SPLIT PIN A2,0X20 UNI 1336	
7	55170047	2	BOOT	
8	56170043	2	COVER	
9	31411130	2	WASHER 13x24	

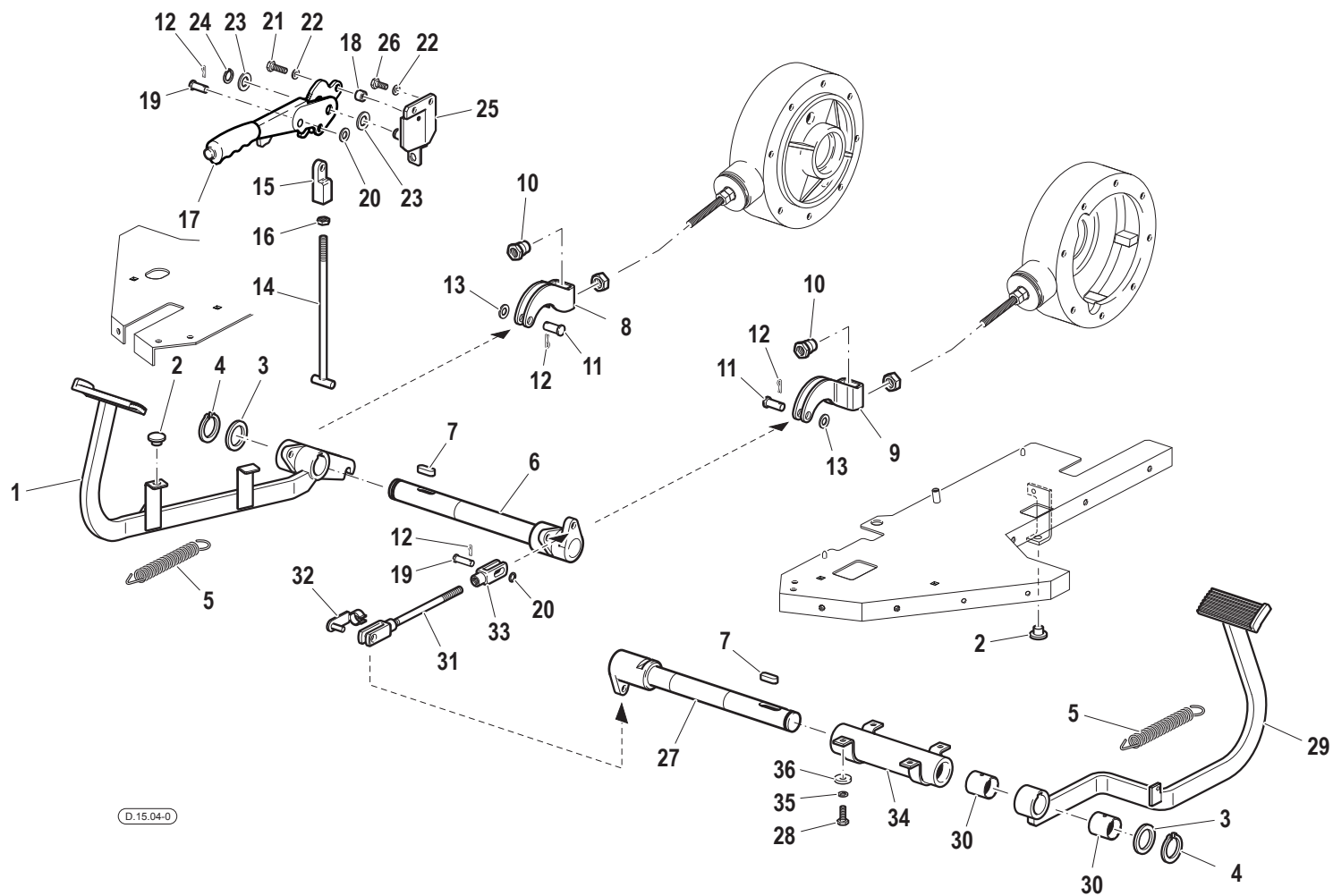

D.15.04-0

Pos.	Code	Q.ty	Description	Notes
1	59077228	1	BRAKE PEDAL	
10	52373177	2	NUT	
11	56470797	2	PIN	
12	F0810510000	4	SPLIT PIN A2,0X20 UNI 1336	
13	31411130	2	WASHER 13x24	
14	52375215	1	HANDBRAKE TIE-ROD	
15	56371721	1	SMALL BLOCK	
16	F0814627000	1	NUT M10	
17	58178960	1	HANDBRAKE LEVER	
18	56171936	1	SPACER	
19	56470365	2	PIN	
2	F0822537050	2	BUFFER	
20	31411105	2	WASHER 10,5x21	
21	31112151	1	SCREW TE M8X25 UNI 5739 8G	
22	F0843643060	7	WASHER 8	
23	31411150	2	WASHER 15x28	
24	F0801095000	1	SEEGER RING E 14 7435	
25	59074459	1	RETAINER	
26	31112147	2	SCREW TE M8X18 UNI 5739 8G	
27	59077234	1	SHAFT	
28	31112146	4	SCREW TE M8X22 UNI 5739 8G	
29	59077233	1	BRAKE PEDAL	
3	56170367	2	SHIM	
30	58170026	2	BUSHING	
31	59073242	1	ROD	
32	F0860091020	1	PIN	
33	50970418	1	FORK	
34	59070051	1	PIPE	
35	F0843711000	4	WASHER D.24x8,5/4	
36	56077235	1	SPACER	
4	F0801241010	2	SEEGER RING E 30 UNI 7436	
5	58070790	2	RESTORING SPRING	
6	59070333	1	SHAFT	
7	34321066	2	KEY A10X8X30 UNI 6604	

SERIAL

BRAKES CONTROLS

CODE REV

D.15.04_0_40488

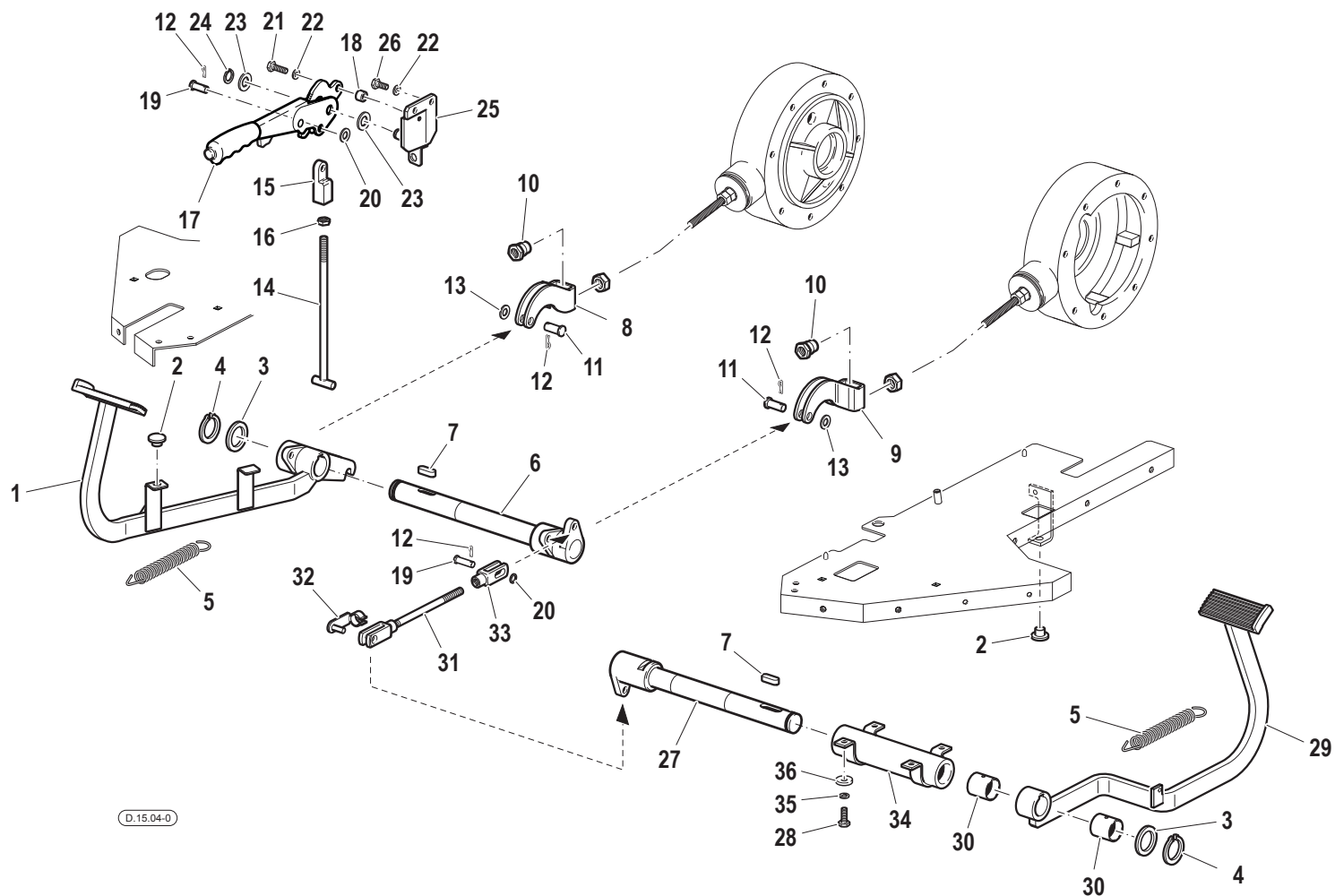

D.15.04-0

Pos.	Code	Q.ty	Description	Notes
8	56170795	1	RIGHT YOKE	
9	56170796	1	LEFT BRACKET	

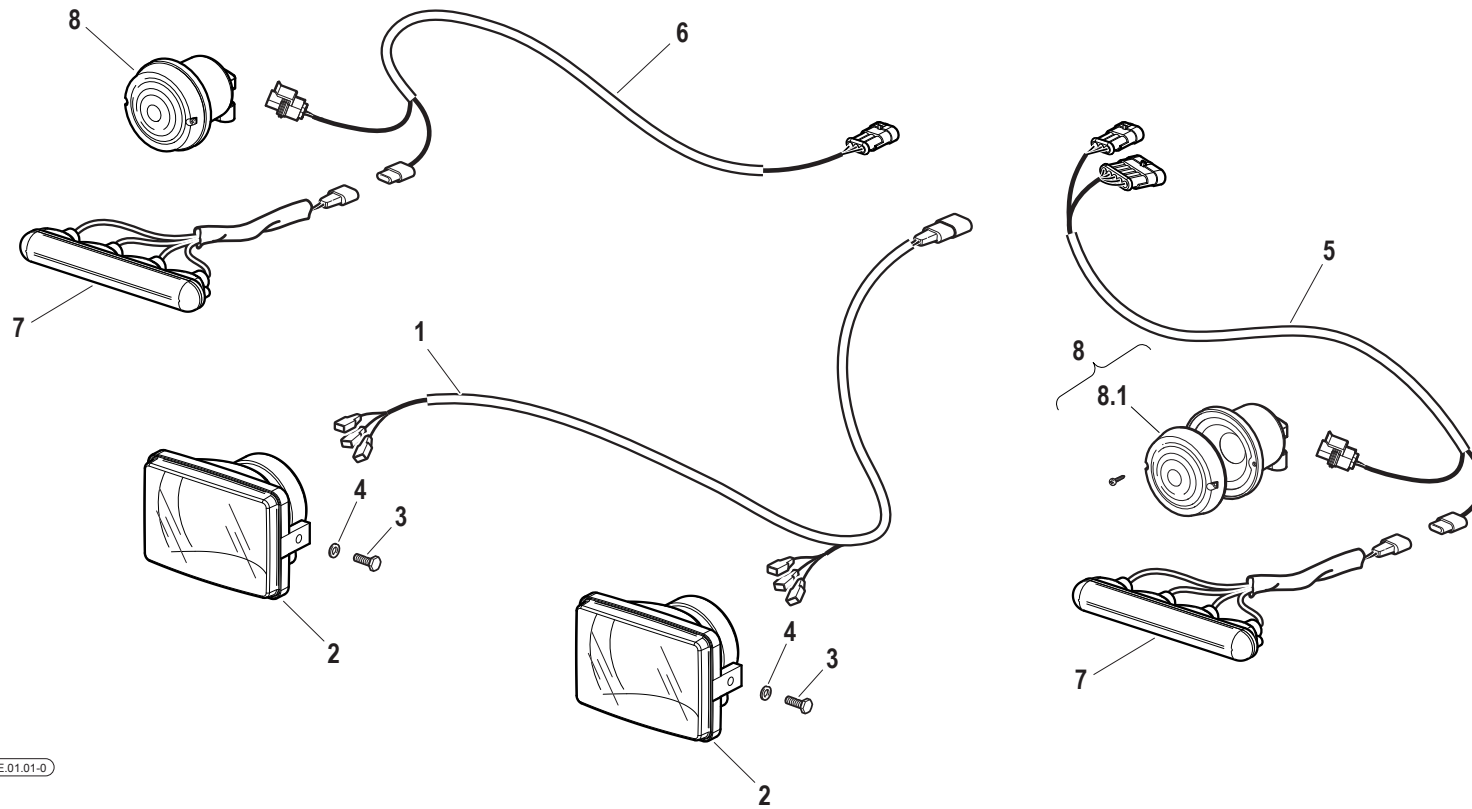

E.01.01-0

Pos.	Code	Q.ty	Description	Notes
1	58074904	1	CABLE	
2	58179010	2	OPTICAL GROUP	
3	31112082	4	SCREW TE M6X12 UNI 5739 8G	
4	31411064	4	WASHER 6,4x12,5	
5	58079395	1	CABLE	
6	58079394	1	CABLE	
7	58176406	2	INDICATOR	
8	58179413	2	POSITION LIGHT	
8.1	59901086	2	VETRO BIANCO FARO ANT.03438001	

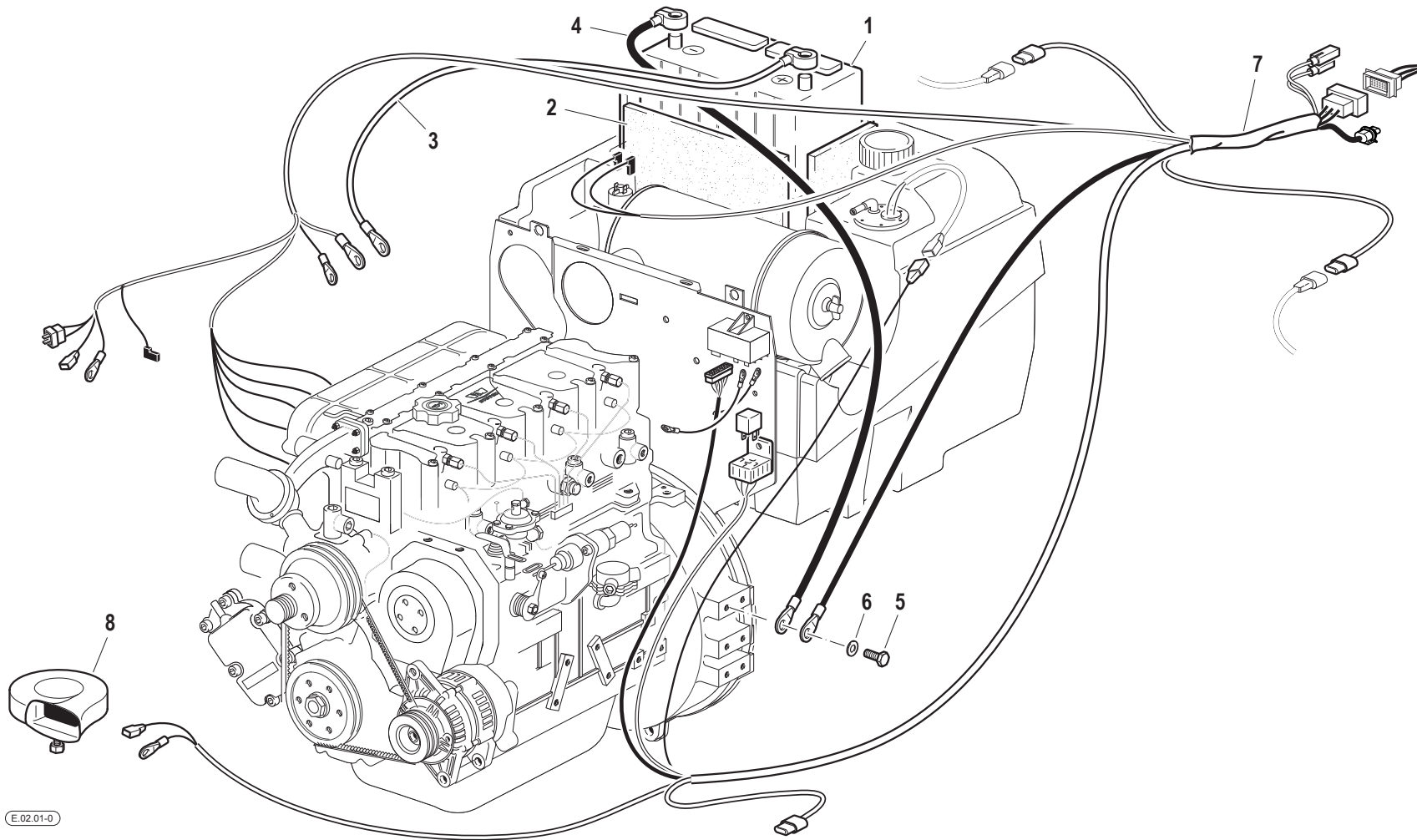

Pos.	Code	Q.ty	Description	Notes
1	F0825480100	1	BATTERY	
2	F0190018909	1	LINING	
3	58071313	1	CABLE	
4	58072081	1	CABLE	
5	31112210	1	SCREW TE M10X20 UNI 5739	
6	F0843755000	1	WASHER 10	
7	58079755	1	CABLE	
8	F0825417000	1	HORN	

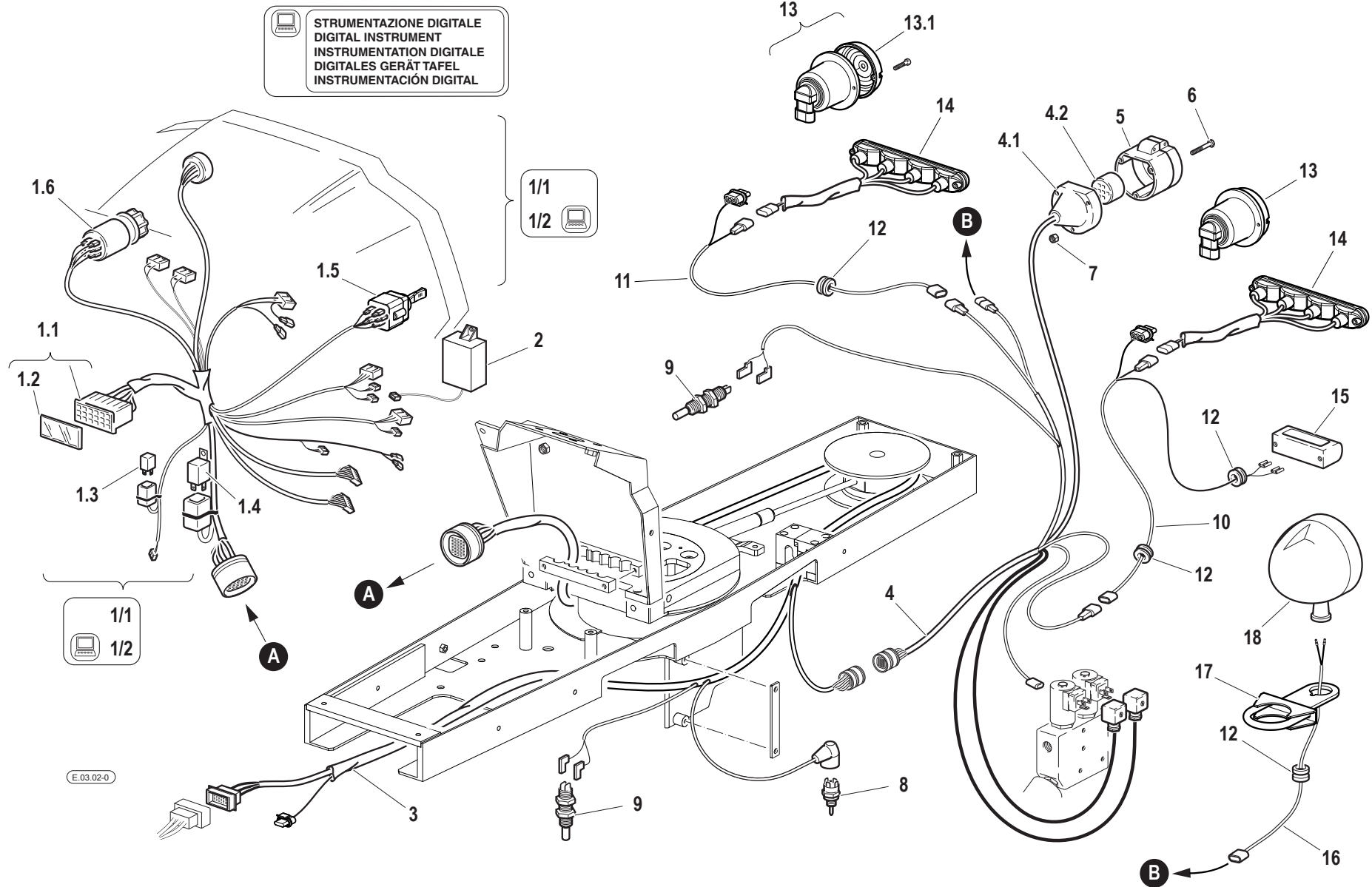

Pos.	Code	Q.ty	Description	Notes
1.1	58170453	1	FUSE BOX	
1.2	58172267	1	COVER	
1.3	59900242	1	RELAY	
1.4	F0825139000	1	FLASHER	
1.5	F0825436000	1	SWITCH	
1.6	F0825436003	1	SWITCH	
1/1	58077601	1	CABLE	
1/2	58077602	1	CABLE	
10	58077061	1	CABLE	
11	58077062	1	CABLE	
12	58171901	4	CABLE GLAND 15,5-24-32-2	
13	58176396	2	LAMP	
13.1	59901087	2	REAR LIGHT GLASS	
14	58176406	2	INDICATOR	
15	30000506	1	LAMP	
16	58077305	1	CABLE	
17	59077242	1	SUPPORT	
18	F0825493000	1	HEADLIGHT	
2	58175700	1	SWITCHING DEVICE	
3	58079392	1	CABLE	
4	58079393	1	CABLE	
4.1	58170572	1	CAP	
4.2	58170571	1	ATTACHMENT PLUG	
5	F0825438000	1	SOCKET	
6	F0861941000	3	SCREW M5X35 UNI 6107	
7	31211050	3	NUT M5	
8	30000638	1	SWITCH	
9	F0825488000	2	SWITCH	

HYDR. SYSTEM DOUBLE OIL SUCTION

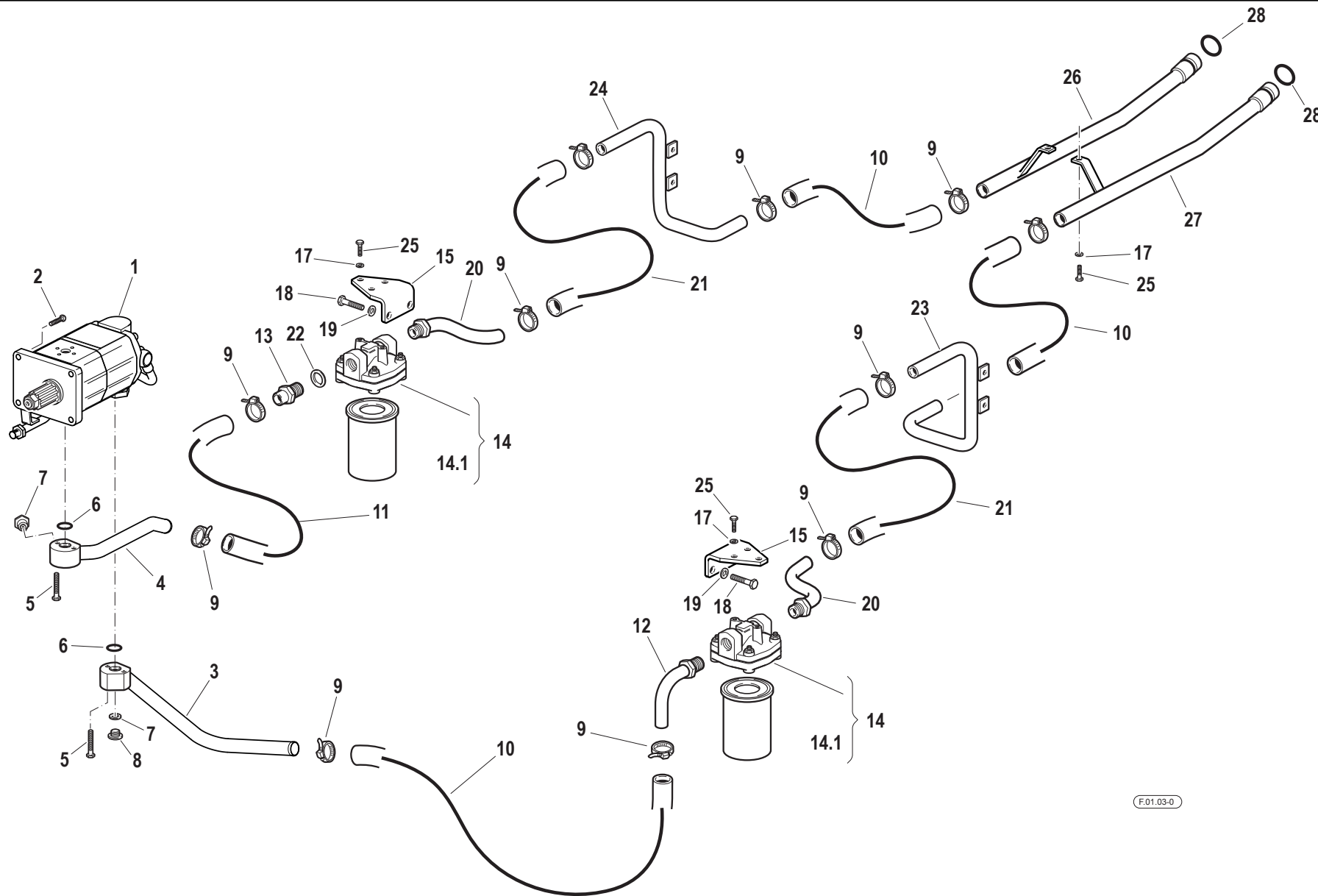

Pos.	Code	Q.ty	Description	Notes
1	58179463	1	LIFT PUMP	
10	58173505	1	FLEXIBLE HOSE	
11	58176337	1	SUCTION PIPE	
12	59076213	1	PIPE	
13	56170350	1	PIPE FITTING	
14	58175014	2	FILTER	
14.1	F0825718020	2	FILTER INSERT	
15	56174725	2	OIL FILTER BRACKET	
16	31111151	4	SCREW TE M8X16 UNI 5739 8G	
17	F0843643060	14	WASHER 8	
18	31112210	4	SCREW TE M10X20 UNI 5739	
19	F0843755000	4	WASHER 10	
2	31152083	4	SCREW TCEI M8X30 UNI 5931	
20	59076212	2	PIPE	
21	58176336	1	SUCTION PIPE	
22	F0824185000	1	COPPER WASHER 26X34X1,5	
23	59076226	1	PIPE	
24	59078595	1	PIPE	
25	31112150	4	SCREW TE M8X20 UNI 5739 8G	
26	59076225	1	SUCTION PIPE	
27	59076224	1	SUCTION PIPE	
28	38113142	2	O-RING	
3	59079479	1	SUCTION PIPE	
4	59076211	1	SUCTION PIPE	
5	F0862796000	4	SCREW M8X40 UNI 5931	
6	38112200	2	O-RING 3087 (22,00X2,62)	
7	F0852538050	1	PLUG	
8	F0843907000	1	COPPER WASHER 13,66x19/1,5	
9	F0817503000	12	CLAMP 037,6-906R	

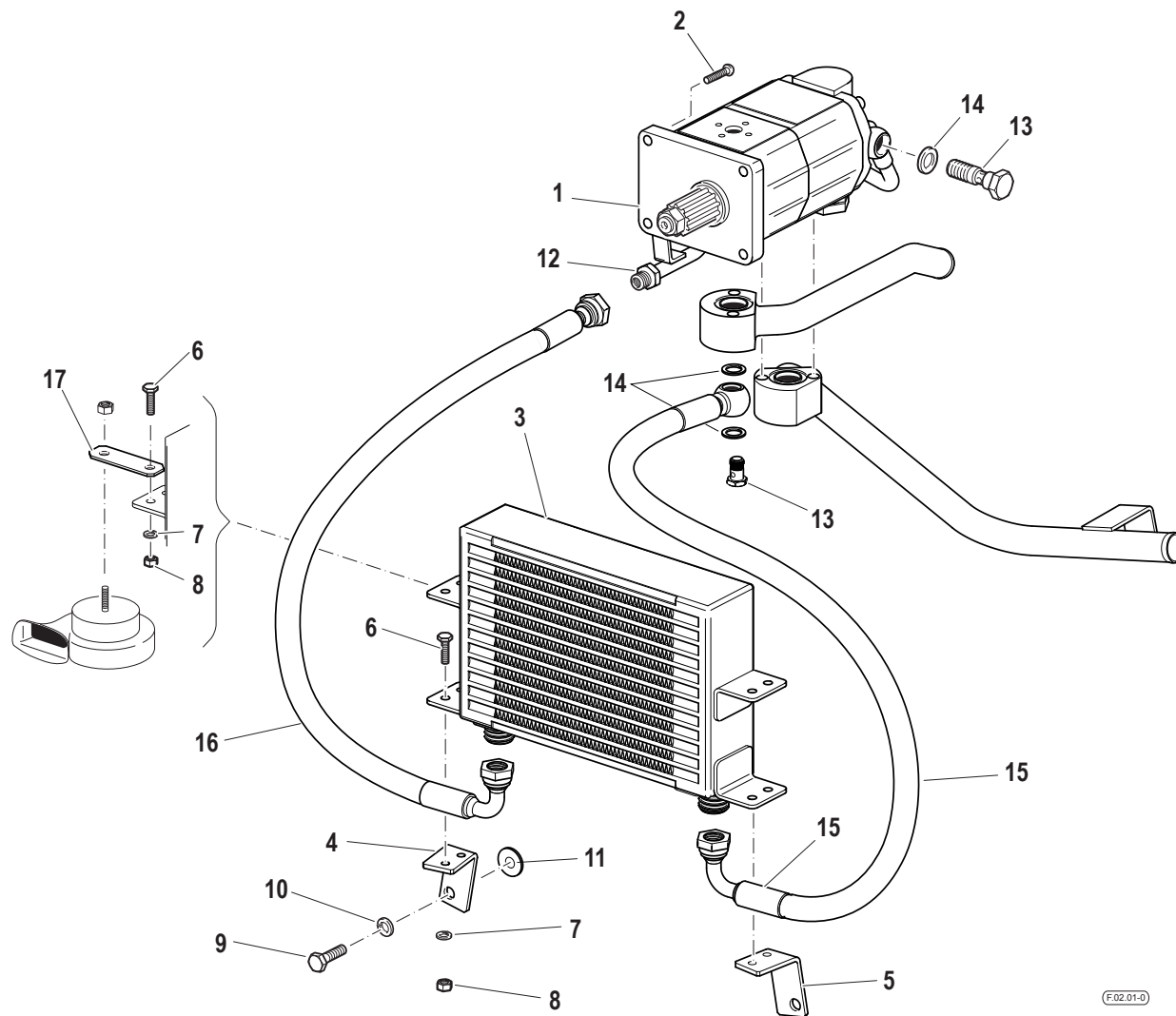

Pos.	Code	Q.ty	Description	Notes
1	58179463	1	LIFT PUMP	
10	F0843755000	2	WASHER 10	
11	F0843815000	2	WASHER D.24x10,5/4	
12	59079478	1	PRESSURE PIPE	
13	56172547	1	THREADED TERMINAL END	
14	F0824113000	2	COPPER WASHER 18X24/1,5	
15	58076333	1	FLEXIBLE HOSE	
16	58076334	1	FLEXIBLE HOSE	
17	56175294	1	BRACKET	
2	31152083	4	SCREW TCEI M8X30 UNI 5931	
3	58177182	1	OIL EXCHANGER	
4	56174987	1	RIGHT YOKE	
5	56174988	1	LEFT BRACKET	
6	31112090	4	SCREW TE M6X16 UNI 5739 8G	
7	F0843570000	4	WASHER 6	
8	31211060	4	NUT M6	
9	31112210	2	SCREW TE M10X20 UNI 5739	

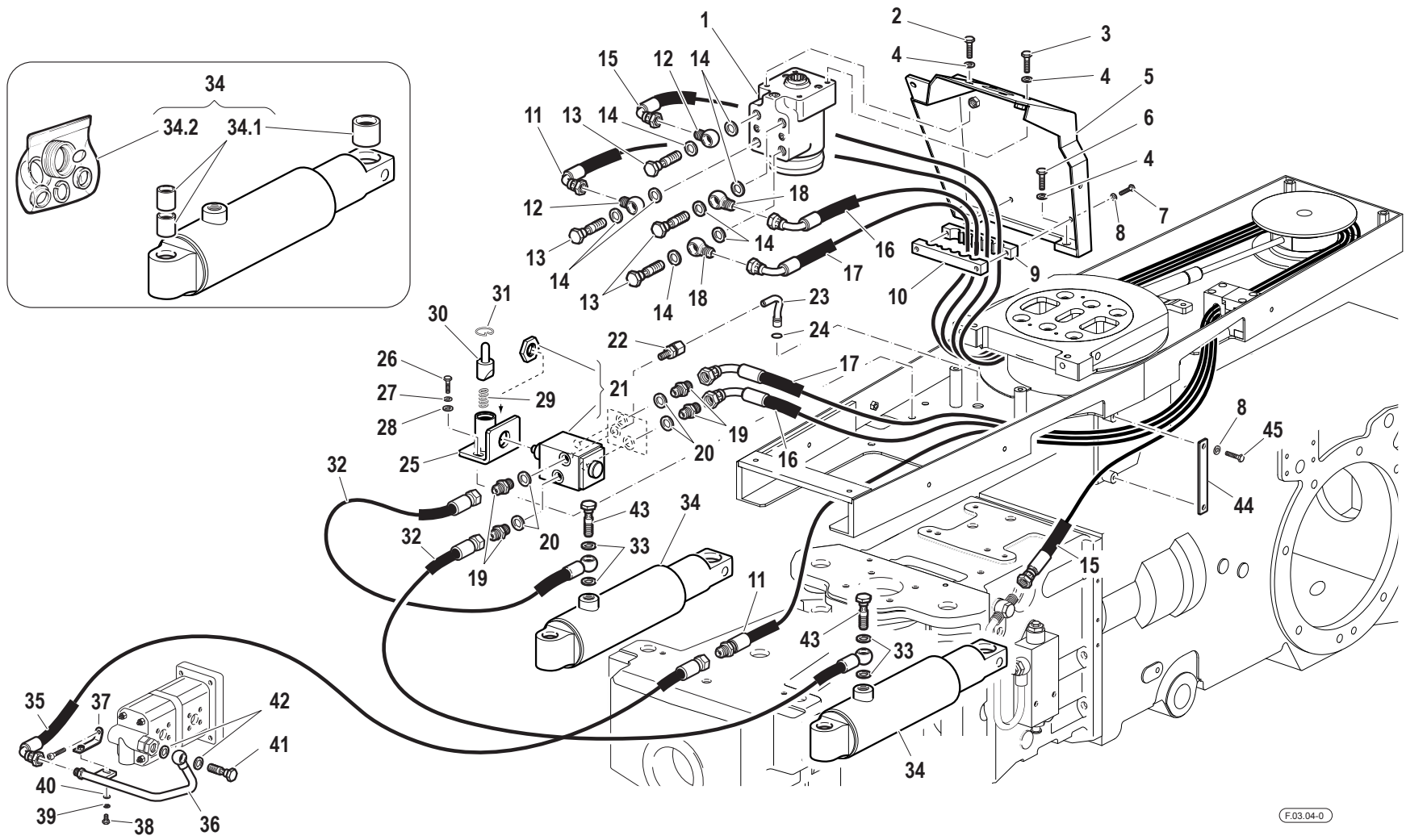

Pos.	Code	Q.ty	Description	Notes
1	58178954	1	HYDROSTEERING	
10	56174480	1	COMB	
11	58074836	1	FLEXIBLE HOSE	
12	F0842512000	2	PIPE FITTING	
13	F0843116000	4	PIPE FITTING 1/2	
14	F0824141000	8	COPPER WASHER 21x27/1,5	
15	58074738	1	RETURN PIPE	
16	58074891	1	FLEXIBLE HOSE	
17	58074740	1	FLEXIBLE HOSE	
18	F0835040030	2	PIPE FITTING	
19	F0835031010	4	NIPPLE	
2	31112210	1	SCREW TE M10X20 UNI 5739	
20	F0843907000	4	COPPER WASHER 13,66x19/1,5	
21	P22733200000	1	D.A. VALVE	
22	58174547	1	NIPPLE	
23	59074546	1	EXHAUST	
24	F0803050000	1	O-RING 2025	
25	59074482	1	PLATE	
26	31112150	2	SCREW TE M8X20 UNI 5739 8G	
27	F0843643060	2	WASHER 8	
28	31411084	2	WASHER 8,4x17	
29	58077413	1	SPRING	
3	31112219	3	SCREW TE M10X25 UNI 5739	
30	56174485	1	CURSOR	
31	F0801163000	1	SEEGER RING I 22 UNI 7437	
32	58074734	2	FLEXIBLE HOSE	
33	F0843948000	4	COPPER WASHER 14,0x20/1,5	
34	58174305	2	CYLINDER	
34.1	59900340	1	BUSHINGS KIT	
34.2	58171737	1	GASKET SET	
35	58075248	1	FLEXIBLE HOSE	
36	59075224	1	PRESSURE PIPE	
37	59075225	1	FIXING BRACKET	
38	31112090	1	SCREW TE M6X16 UNI 5739 8G	

SERIAL

STEERING HYDR. SYSTEM

CODE REV

F.03.04_0_40779

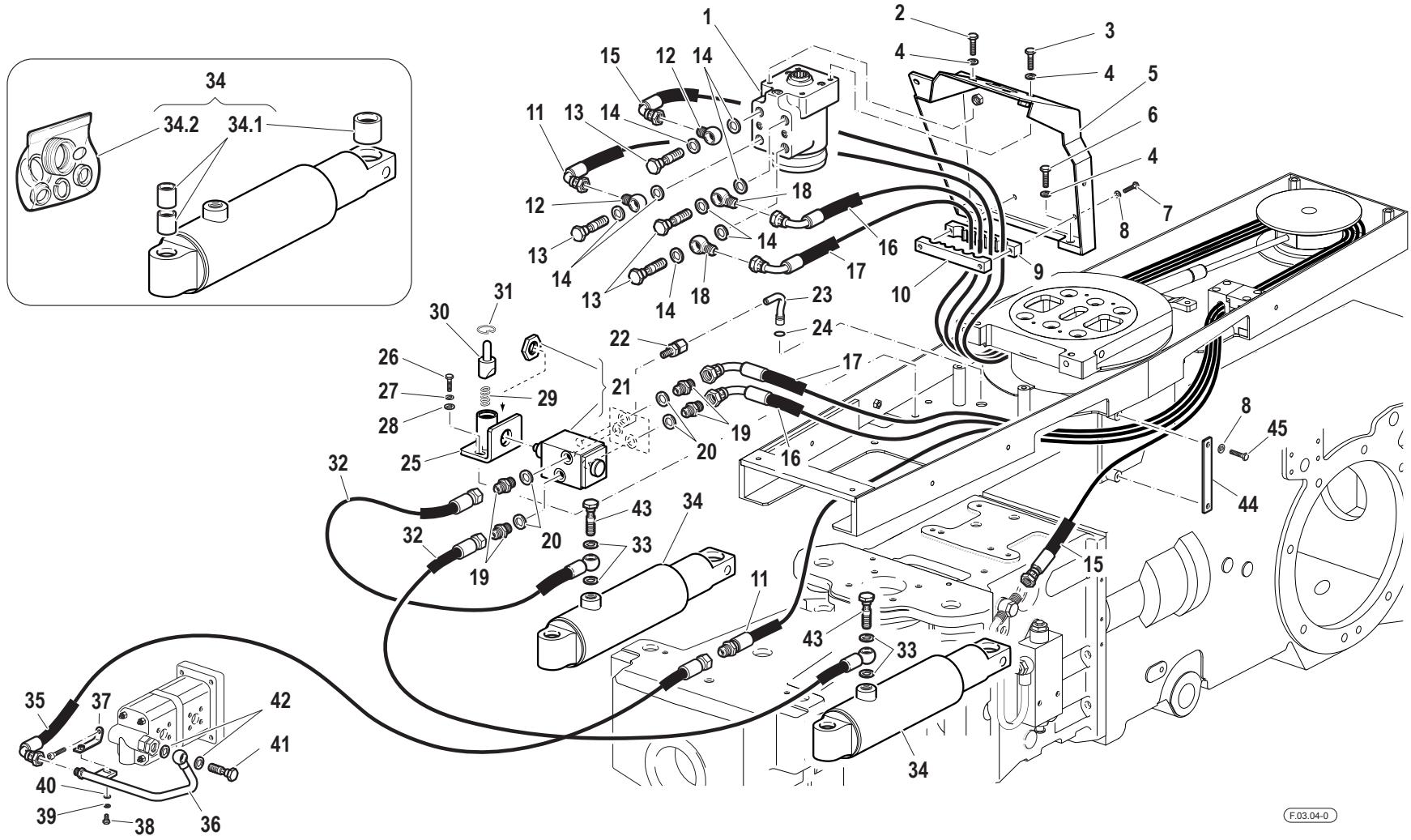

Pos.	Code	Q.ty	Description	Notes
39	F0843570000	1	WASHER 6	
4	F0843755000	6	WASHER 10	
40	31411064	1	WASHER 6,4x12,5	
41	F0843110010	1	THREADED TERMINAL END M18x1,5	
42	F0824113000	2	COPPER WASHER 18X24/1,5	
43	F0843109000	2	PIPE FITTING 14x1,5	
44	56174494	1	SMALL PLATE	
45	F0862129000	2	SCREW M6X18 UNI 5739 8.8	
5	59074332	1	SUPPORT	
6	31112211	2	SCREW TE M10X30 UNI 5739	
7	31112092	2	SCREW TE M6X35 UNI 5739 8G	
8	F0843570000	4	WASHER 6	
9	56174481	1	COMB	

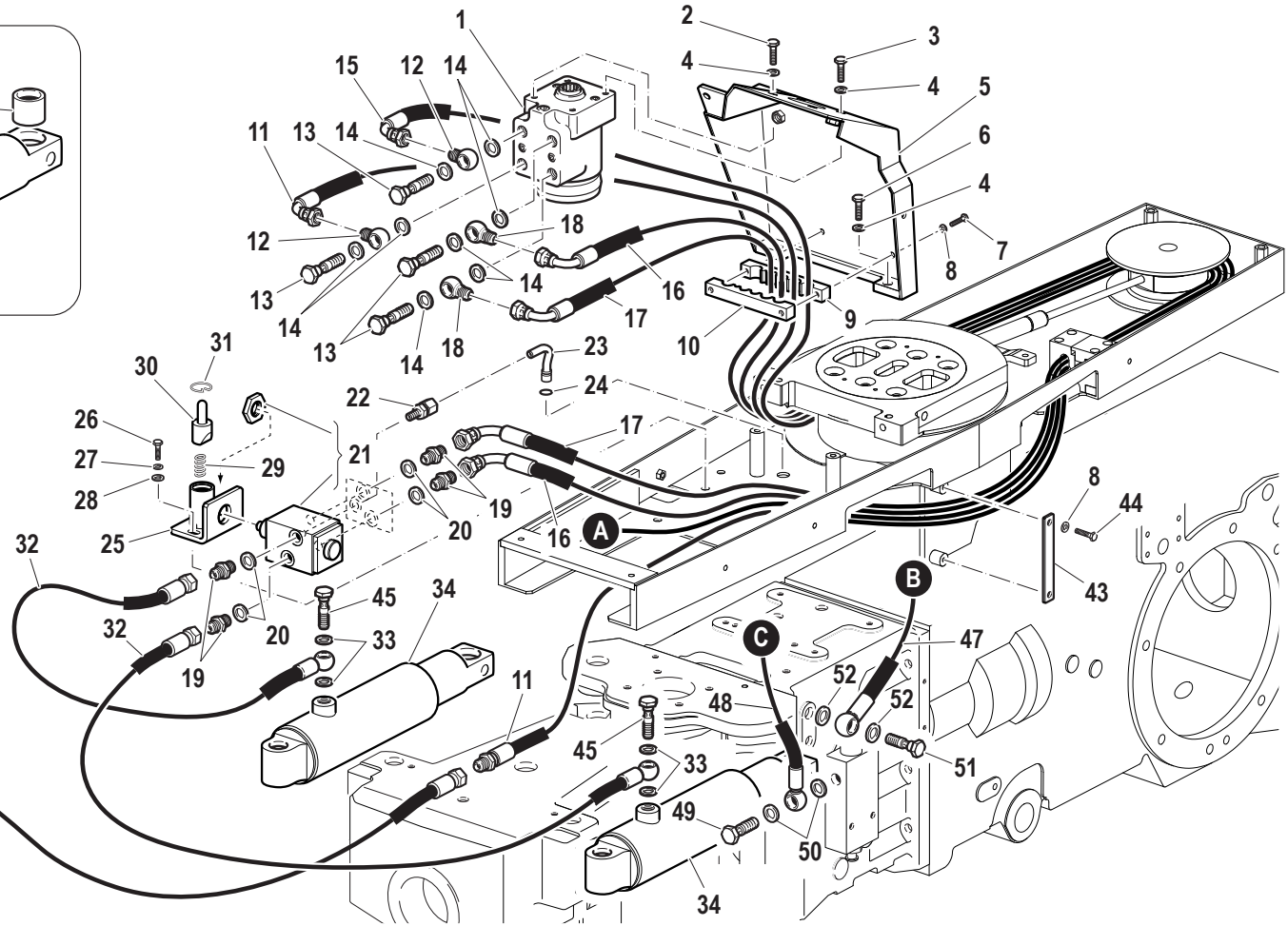
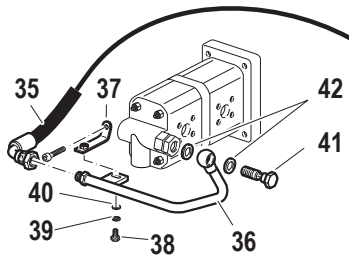
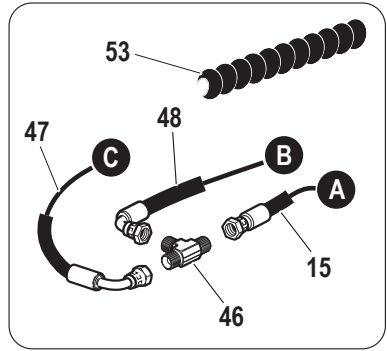
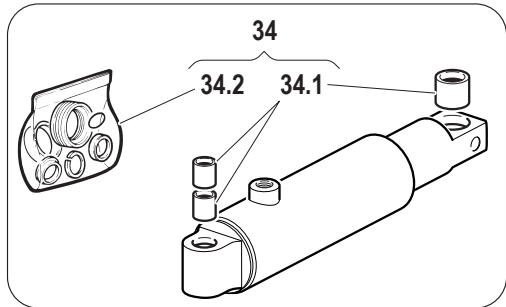

Pos.	Code	Q.ty	Description	Notes
1	58178954	1	HYDROSTEERING	
10	56174480	1	COMB	
11	58074836	1	FLEXIBLE HOSE	
12	F0842512000	2	PIPE FITTING	
13	F0843116000	4	PIPE FITTING 1/2	
14	F0824141000	8	COPPER WASHER 21x27/1,5	
15	58079433	1	FLEXIBLE HOSE	
16	58074891	1	FLEXIBLE HOSE	
17	58074740	1	FLEXIBLE HOSE	
18	F0835040030	2	PIPE FITTING	
19	F0835031010	4	NIPPLE	
2	31112210	1	SCREW TE M10X20 UNI 5739	
20	F0843907000	4	COPPER WASHER 13,66x19/1,5	
21	P22733200000	1	D.A. VALVE	
22	58174547	1	NIPPLE	
23	59074546	1	EXHAUST	
24	F0803050000	1	O-RING 2025	
25	59074482	1	PLATE	
26	31112150	2	SCREW TE M8X20 UNI 5739 8G	
27	F0843643060	2	WASHER 8	
28	31411084	2	WASHER 8,4x17	
29	58077413	1	SPRING	
3	31112219	3	SCREW TE M10X25 UNI 5739	
30	56174485	1	CURSOR	
31	F0801163000	1	SEEGER RING I 22 UNI 7437	
32	58074734	2	FLEXIBLE HOSE	
33	F0843948000	4	COPPER WASHER 14,0x20/1,5	
34	58174305	2	CYLINDER	
34.1	59900340	1	BUSHINGS KIT	
34.2	58171737	1	GASKET SET	
35	58075248	1	FLEXIBLE HOSE	
36	59075224	1	PRESSURE PIPE	
37	59075225	1	FIXING BRACKET	
38	31112090	1	SCREW TE M6X16 UNI 5739 8G	

SERIAL

913641

STEERING HYDR. SYSTEM

CODE REV

F.03.04_1_40827

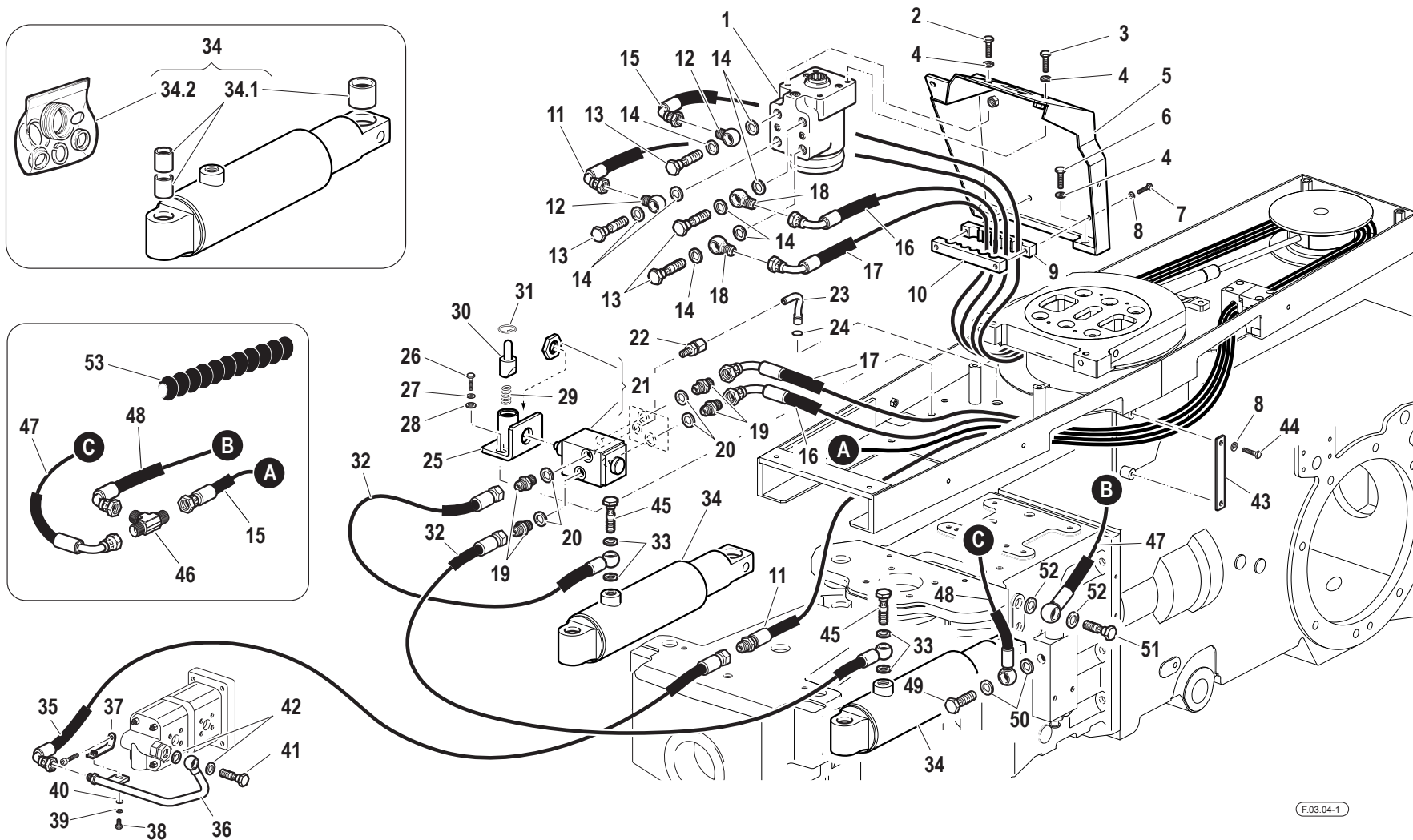

Pos.	Code	Q.ty	Description	Notes
39	F0843570000	1	WASHER 6	
4	F0843755000	6	WASHER 10	
40	31411064	1	WASHER 6,4x12,5	
41	F0843110010	1	THREADED TERMINAL END M18x1,5	
42	F0824113000	2	COPPER WASHER 18X24/1,5	
43	56174494	1	SMALL PLATE	
44	F0862129000	2	SCREW M6X18 UNI 5739 8.8	
45	F0843109000	2	PIPE FITTING 14x1,5	
46	30000795	1	ADATT.3 VIE 3/8 OR:TI05060606	
47	58079435	1	PRESSURE HOSE	
48	58079434	1	PRESSURE HOSE	
49	F0843107000	1	PIPE FITTING GAS 1/4	
5	59074332	1	SUPPORT	
50	F0843907000	2	COPPER WASHER 13,66x19/1,5	
51	F0843109020	1	PIPE FITTING	
52	F0824110000	2	COPPER WASHER 3/8 GAS	
53	F0256909000	1	GUARD	
6	31112211	2	SCREW TE M10X30 UNI 5739	
7	31112092	2	SCREW TE M6X35 UNI 5739 8G	
8	F0843570000	2	WASHER 6	
9	56174481	1	COMB	

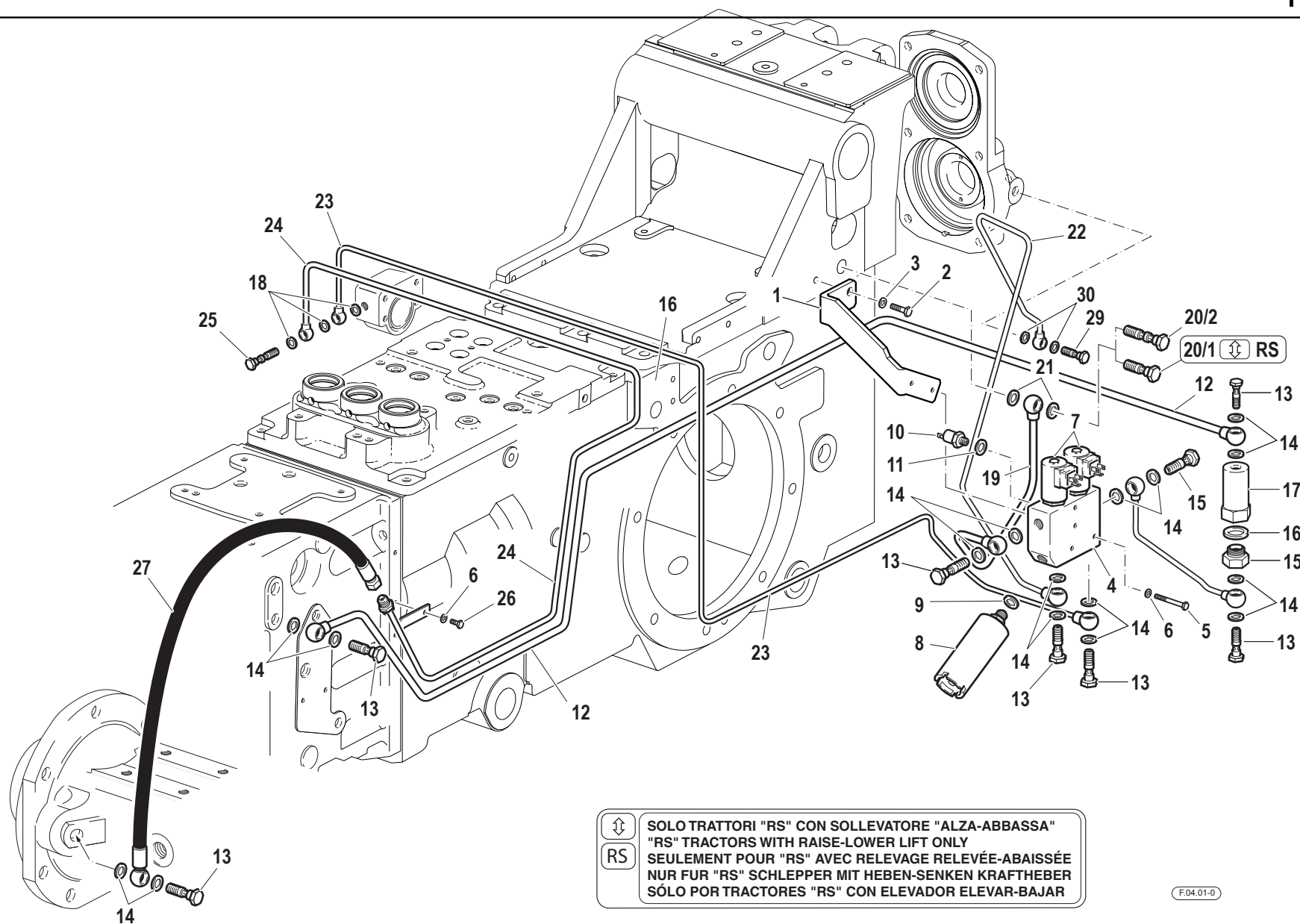

Pos.	Code	Q.ty	Description	Notes
1	56174665	1	SUPPORT	
10	58173399	1	PRESSURE SWITCH	
11	F0843841000	1	COPPER WASHER 12,0x18/1,5	
12	59075678	1	PRESSURE PIPE	
13	F0843107000	8	PIPE FITTING GAS 1/4	
14	F0843907000	16	COPPER WASHER 13,66x19/1,5	
15	58175677	1	HEAD	
16	F0824185000	1	COPPER WASHER 26X34X1,5	
17	58175676	1	BODY	
18	F0843771000	3	COPPER WASHER 10,0x16/1	
19	59074744	1	EXHAUST	
2	31112150	2	SCREW TE M8X20 UNI 5739 8G	
20/1	F0843109020	1	PIPE FITTING	
20/2	58170693	1	PIPE FITTING	
21	F0824110000	2	COPPER WASHER 3/8 GAS	
22	59075917	1	PRESSURE PIPE	
23	59074748	1	PRESSURE PIPE	
24	59074749	1	PRESSURE PIPE	
25	58174732	1	HOLLOW SCREW	
26	31111090	1	SCREW TE M5X10 UNI 5739 8G	
27	58074736	1	FLEXIBLE HOSE	
28	59075679	1	PIPE	
29	56178695	1	THREADED TERMINAL END	
3	F0843643060	2	WASHER 8	
30	P25412400000	2	WASHER	
4	56172749	1	SMALL BLOCK	
5	F0862345000	2	SCREW M6X40 UNI 5737	
6	F0843570000	3	WASHER 6	
7	58172463	2	ELECTRO VALVE	
8	59271011	1	UNIT	
9	F0843948000	1	COPPER WASHER 14,0x20/1,5	

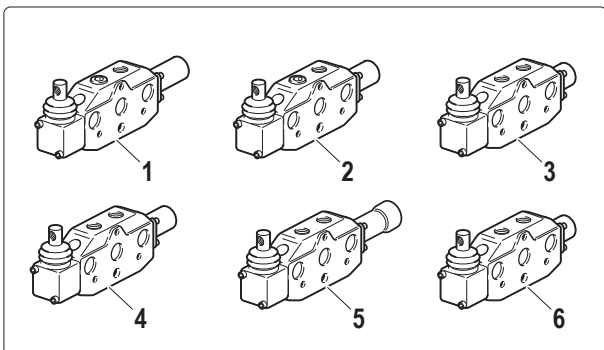

- VEDI TAVOLE GRUPPI...
- SEE TABLES OF GROUPS...
- VOIR TABLES GROUPES...
- SIEHE GRUPPETAFFEL...
- MIRAR TABLAS GRUPOS...

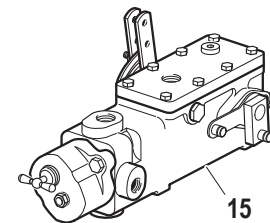
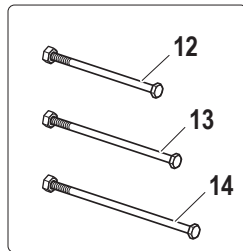
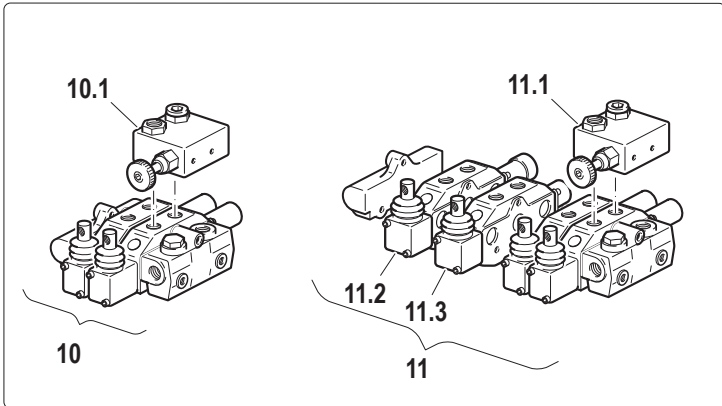
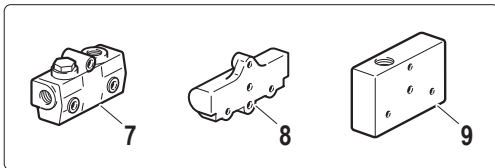

VEDI TAVOLE GRUPPO...
SEE TABLES OF GROUP...
VOIR TABLES GROUPE...
SIEHE GRUPPETAFFEL...
MIRAR TABLAS GRUPO...



Pos.	Code	Q.ty	Description	Notes
1	58172011	1	S.A. VALVE	
10	58171925	1	FLOATING DEVICE GROUP	
10.1	59900230	1	VALVE	
11	58174974	1	FLOATING DEVICE GROUP	
11.1	59900230	1	VALVE	
11.2	58172014	1	D.A. VALVE	
11.3	58172240	1	D.A. VALVE	
12	58172016	1	ROD	
13	58172017	1	ROD	
14	58172018	1	ROD	
15	58175191	1	DISTRIBUTOR	
2	58172707	1	S.A. VALVE	
3	58172012	1	D.A. VALVE	
4	58172013	1	D.A. VALVE	
5	58172014	1	D.A. VALVE	
6	58172240	1	D.A. VALVE	
7	58172304	1	HEAD	
8	58172489	1	COVER	
9	58173361	1	COVER	

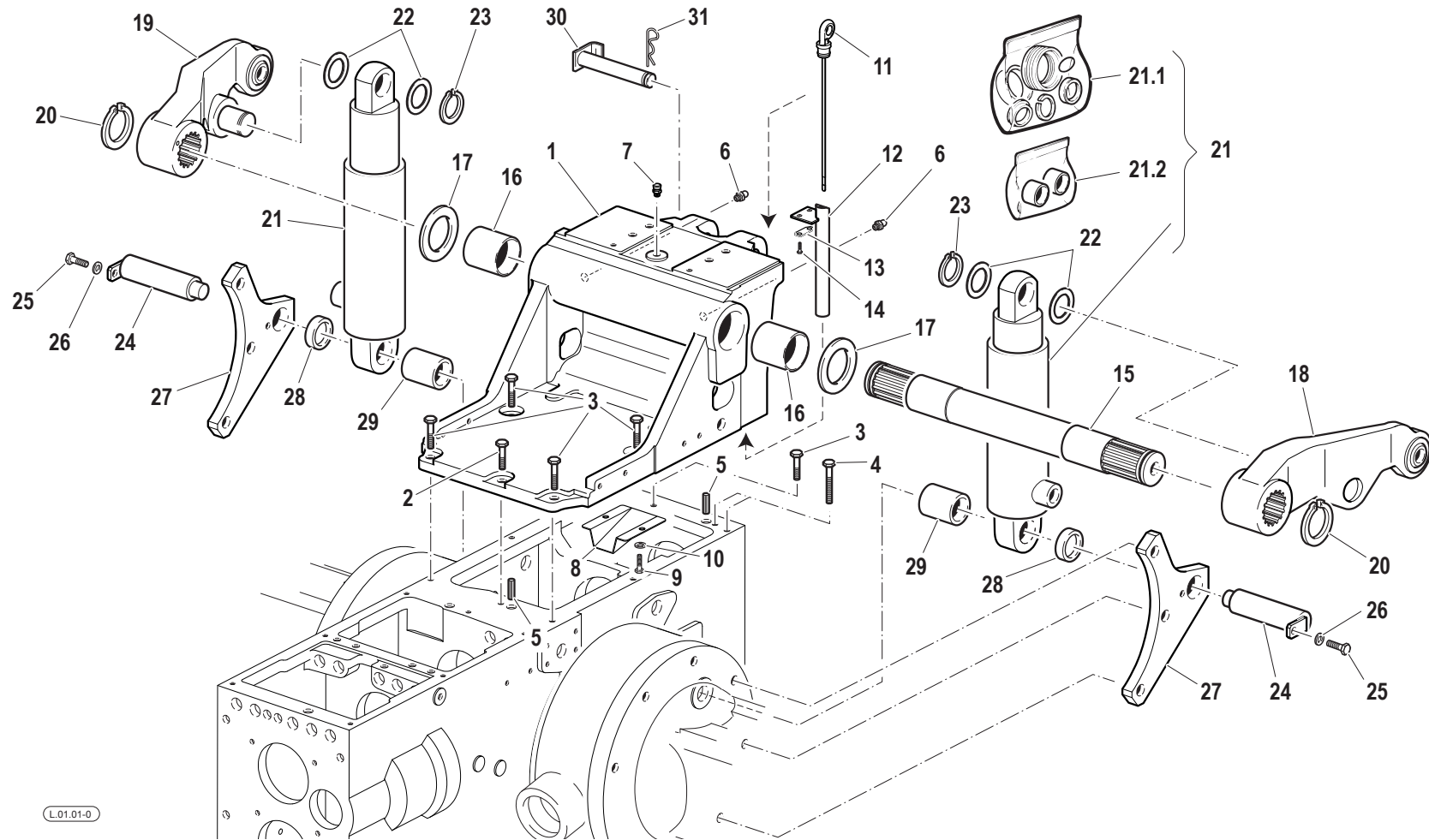

Pos.	Code	Q.ty	Description	Notes
1	51174315	1	SUPPORT	
10	F0843643060	2	WASHER 8	
11	58174581	1	OIL LEVEL ROD	
12	59076085	1	OIL PIPE	
13	52071702	1	CLAMPING PLATE	
14	31112082	2	SCREW TE M6X12 UNI 5739 8G	
15	56570284	1	SHAFT	
16	58170291	2	BUSHING	
17	56370288	2	SHIM	
18	59070289	1	LIFTING ARM	
19	59070290	1	RIGHT ARM	
2	31112219	1	SCREW TE M10X25 UNI 5739	
20	F0801331050	2	SEEGER RING E 45 UNI 7436	
21	58170245	2	LIFTING CYLINDER	
21.1	58171537	1	GASKET SET	
21.2	58171536	1	BUSHINGS KIT	
22	56370282	4	SHIM	
23	F0801241010	2	SEEGER RING E 30 UNI 7436	
24	56370287	2	HINGE PIN	
25	31112150	2	SCREW TE M8X20 UNI 5739 8G	
26	F0843643060	2	WASHER 8	
27	56170283	2	BRACKET	
28	56170286	2	SPACER	
29	56170285	2	SPACER	
3	31112211	5	SCREW TE M10X30 UNI 5739	
30	59078588	1	CONNECTING BOLT	
31	F0851486000	1	SPLIT PIN	
4	F0863429000	4	SCREW M10X45 UNI 5737	
5	56570016	2	CYLINDRICAL PLUG	
6	F0826056000	1	LUBRICATOR M10 UNI 7663A	
7	58075603	1	PLUG	
8	56173638	1	GUARD	
9	31112149	2	SCREW TE M8X12 UNI 5739 8G	

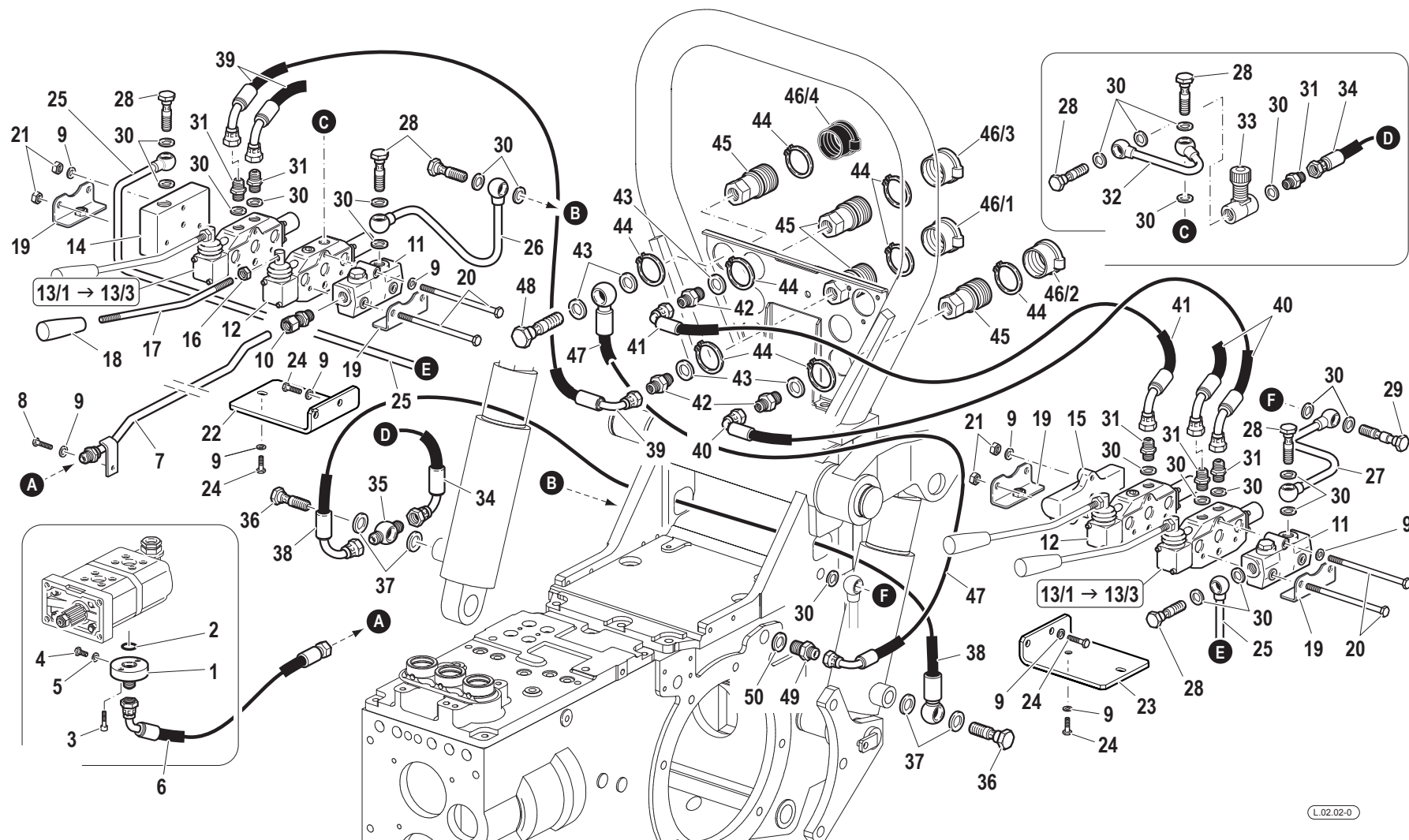

Pos.	Code	Q.ty	Description	Notes
1	F0825809000	1	PRESSURE PIPE CONNECTOR	
10	58172015	1	PIPE FITTING	
11	58172304	2	HEAD	
12	58172011	2	S.A. VALVE	
13/1	58172012	2	D.A. VALVE	
13/2	58172013	2	D.A. VALVE	
13/3	58172014	2	D.A. VALVE	
14	58173361	1	COVER	
15	58172489	1	COVER	
16	31211100	4	NUT M10	
17	56170964	4	COMMAND LEVER	
18	F0837534010	4	GRIP	
19	59072057	4	FIXING BRACKET	
2	F0803185000	1	O-RING 3068 (17,12x2,62)	
20	58172016	6	ROD	
21	31211080	12	NUT M8	
22	56174227	1	RIGHT YOKE	
23	56174201	1	LEFT BRACKET	
24	31112150	8	SCREW TE M8X20 UNI 5739 8G	
25	59075037	1	PIPE	
26	59074759	1	OIL PIPE	
27	59075039	1	EXHAUST	
28	F0843109020	7	PIPE FITTING	
29	58170693	1	PIPE FITTING	
3	31152057	2	SCREW TCEI M6X16 UNI 5931	
30	F0824110000	23	COPPER WASHER 3/8 GAS	
31	30000197	6	NIPPLE	
32	59075360	1	PRESSURE PIPE	
33	P24117100000	1	VALVE	
34	58075358	1	FLEXIBLE HOSE	
35	58170512	1	EYELET	
36	F0843110010	2	THREADED TERMINAL END M18x1,5	
37	F0824113000	4	COPPER WASHER 18X24/1,5	
38	58070513	1	FLEXIBLE HOSE	

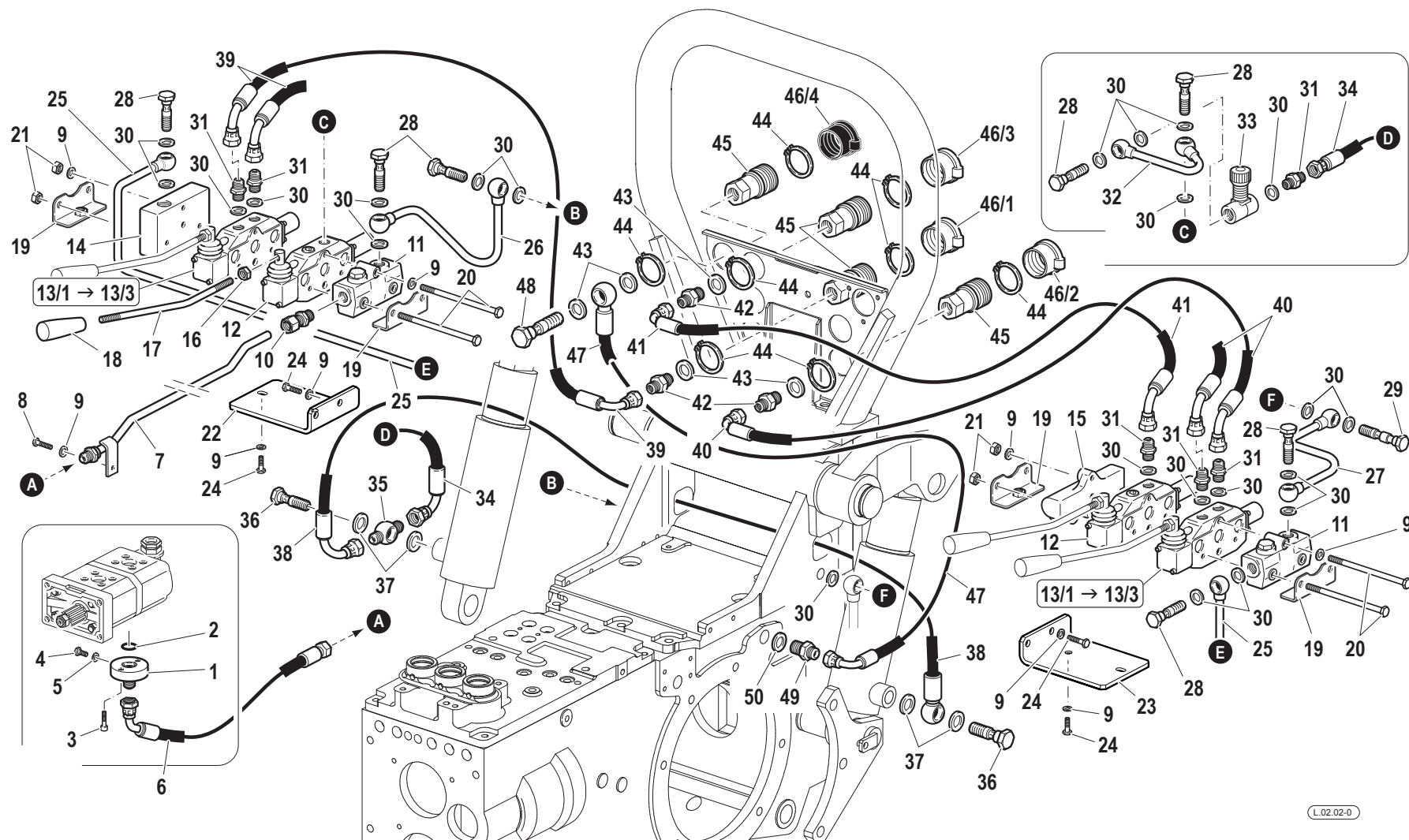

Pos.	Code	Q.ty	Description	Notes
39	58075080	2	FLEXIBLE HOSE	
4	F0862462010	1	SCREW M8X1/12 UNI5740	
40	58074958	2	FLEXIBLE HOSE	
41	58075226	1	FLEXIBLE HOSE	
42	F0835037000	5	NIPPLE	
43	F0824141000	5	COPPER WASHER 21x27/1,5	
44	F0801282000	12	SEEGER RING E 38 UNI 7435	
45	F0825980030	6	COUPLING	
46/1	F0852550010	2	GUARD	
46/2	F0852550020	2	GUARD	
46/3	F0852550030	1	GUARD	
46/4	F0852550040	1	GUARD	
47	58075082	1	FLEXIBLE HOSE	
48	F0843116000	1	PIPE FITTING 1/2	
49	58175083	1	NIPPLE	
5	F0824022000	1	SPECIAL GASKET D.8,4X12/1	
50	F0844273090	1	GASKET 22X28X1,5 CU 99,5	
6	58075247	1	FLEXIBLE HOSE	
7	59074754	1	PRESSURE PIPE	
8	31111151	1	SCREW TE M8X16 UNI 5739 8G	
9	F0843643060	13	WASHER 8	

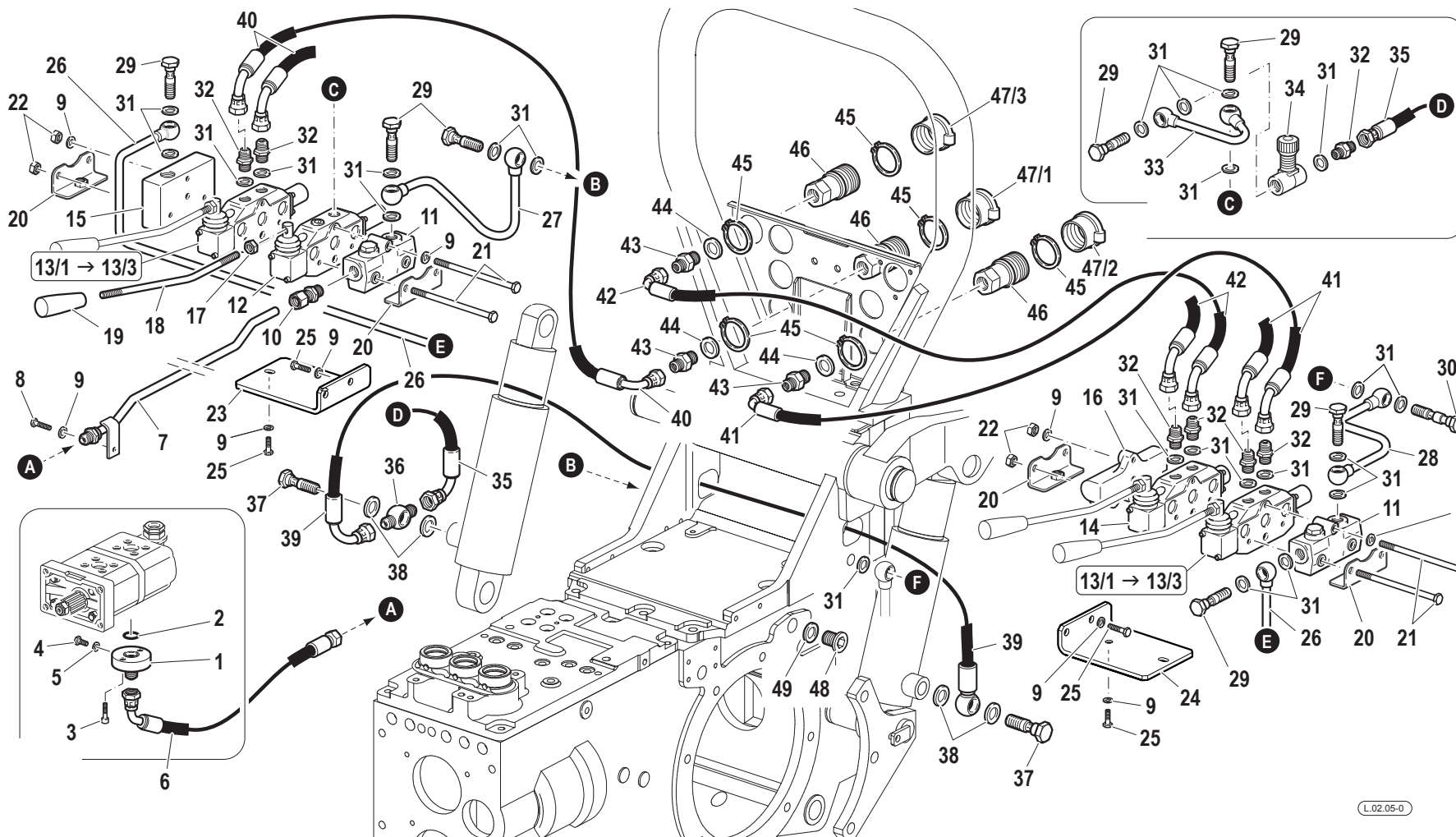

Pos.	Code	Q.ty	Description	Notes
1	F0825809000	1	PRESSURE PIPE CONNECTOR	
10	58172015	1	PIPE FITTING	
11	58172304	2	HEAD	
12	58172011	1	S.A. VALVE	
13/1	58172012	2	D.A. VALVE	
13/2	58172013	2	D.A. VALVE	
13/3	58172014	2	D.A. VALVE	
14	58172012	1	D.A. VALVE	
15	58173361	1	COVER	
16	58172489	1	COVER	
17	31211100	4	NUT M10	
18	56170964	4	COMMAND LEVER	
19	F0837534010	4	GRIP	
2	F0803185000	1	O-RING 3068 (17,12x2,62)	
20	59072057	4	FIXING BRACKET	
21	58172016	6	ROD	
22	31211080	6	NUT M8	
23	56174227	1	RIGHT YOKE	
24	56174201	1	LEFT BRACKET	
25	31112150	8	SCREW TE M8X20 UNI 5739 8G	
26	59075037	1	PIPE	
27	59074759	1	OIL PIPE	
28	59075039	1	EXHAUST	
29	F0843109020	7	PIPE FITTING	
3	31152057	2	SCREW TCEI M6X16 UNI 5931	
30	58170693	1	PIPE FITTING	
31	F0824110000	24	COPPER WASHER 3/8 GAS	
32	30000197	7	NIPPLE	
33	59075360	1	PRESSURE PIPE	
34	P24117100000	1	VALVE	
35	58075358	1	FLEXIBLE HOSE	
36	58170512	1	EYELET	
37	F0843110010	2	THREADED TERMINAL END M18x1,5	
38	F0824113000	4	COPPER WASHER 18X24/1,5	

SERIAL

CONTROL VALVES WITHOUT FREE DISCHARGE VERSION

CODE REV

L.02.05_0_41145

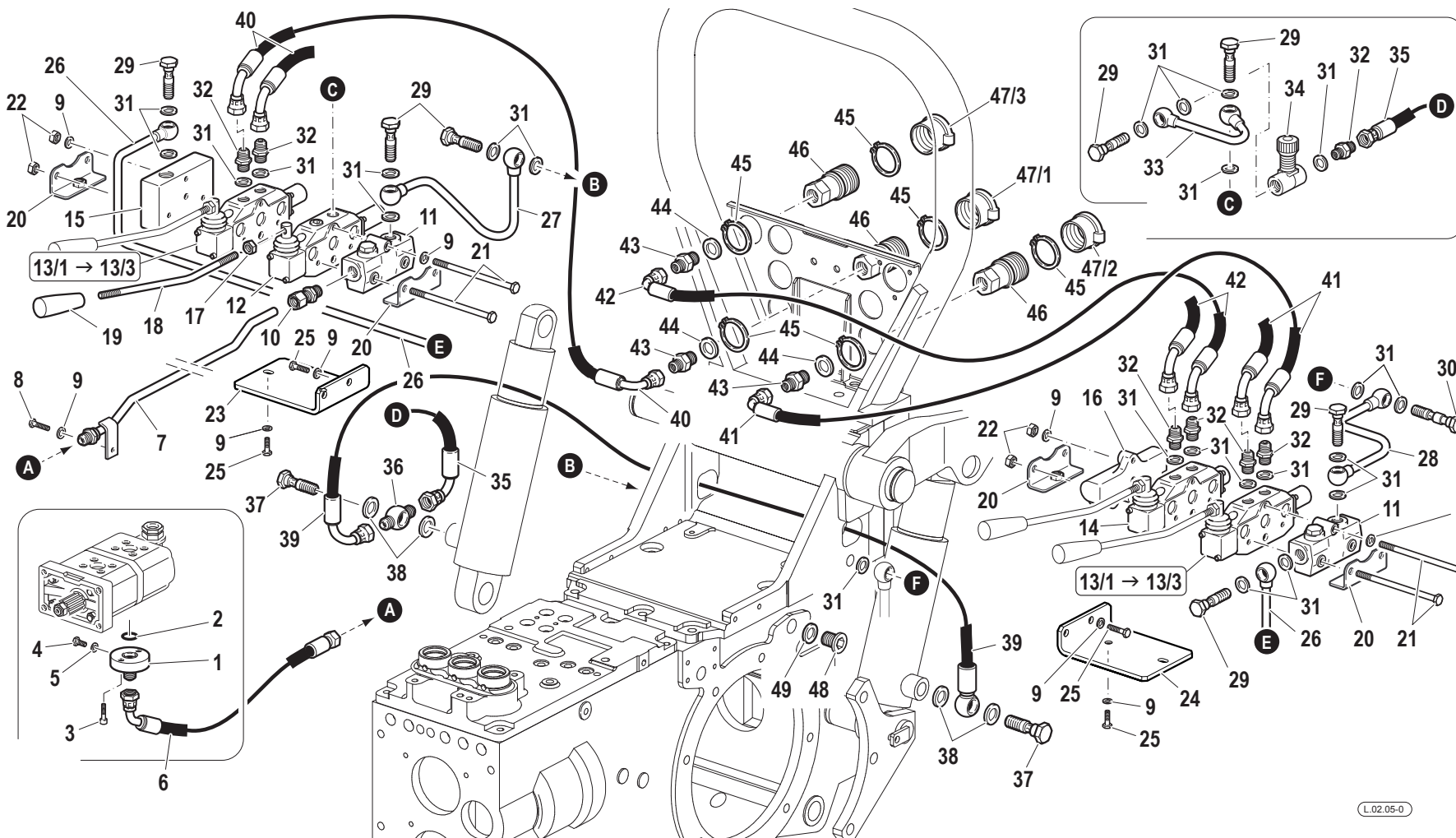

Pos.	Code	Q.ty	Description	Notes
39	58070513	1	FLEXIBLE HOSE	
4	F0862462010	1	SCREW M8X1/12 UNI5740	
40	58075080	2	FLEXIBLE HOSE	
41	58074958	2	FLEXIBLE HOSE	
42	58075226	2	FLEXIBLE HOSE	
43	F0835037000	6	NIPPLE	
44	F0824141000	6	COPPER WASHER 21x27/1,5	
45	F0801282000	12	SEEGER RING E 38 UNI 7435	
46	F0825980030	6	COUPLING	
47/1	F0852550010	2	GUARD	
47/2	F0852550020	2	GUARD	
47/3	F0852550030	2	GUARD	
48	56370081	1	PLUG	
49	F0844273090	1	GASKET 22X28X1,5 CU 99,5	
5	F0824022000	1	SPECIAL GASKET D.8,4X12/1	
6	58075247	1	FLEXIBLE HOSE	
7	59074754	1	PRESSURE PIPE	
8	31111151	1	SCREW TE M8X16 UNI 5739 8G	
9	F0843643060	13	WASHER 8	

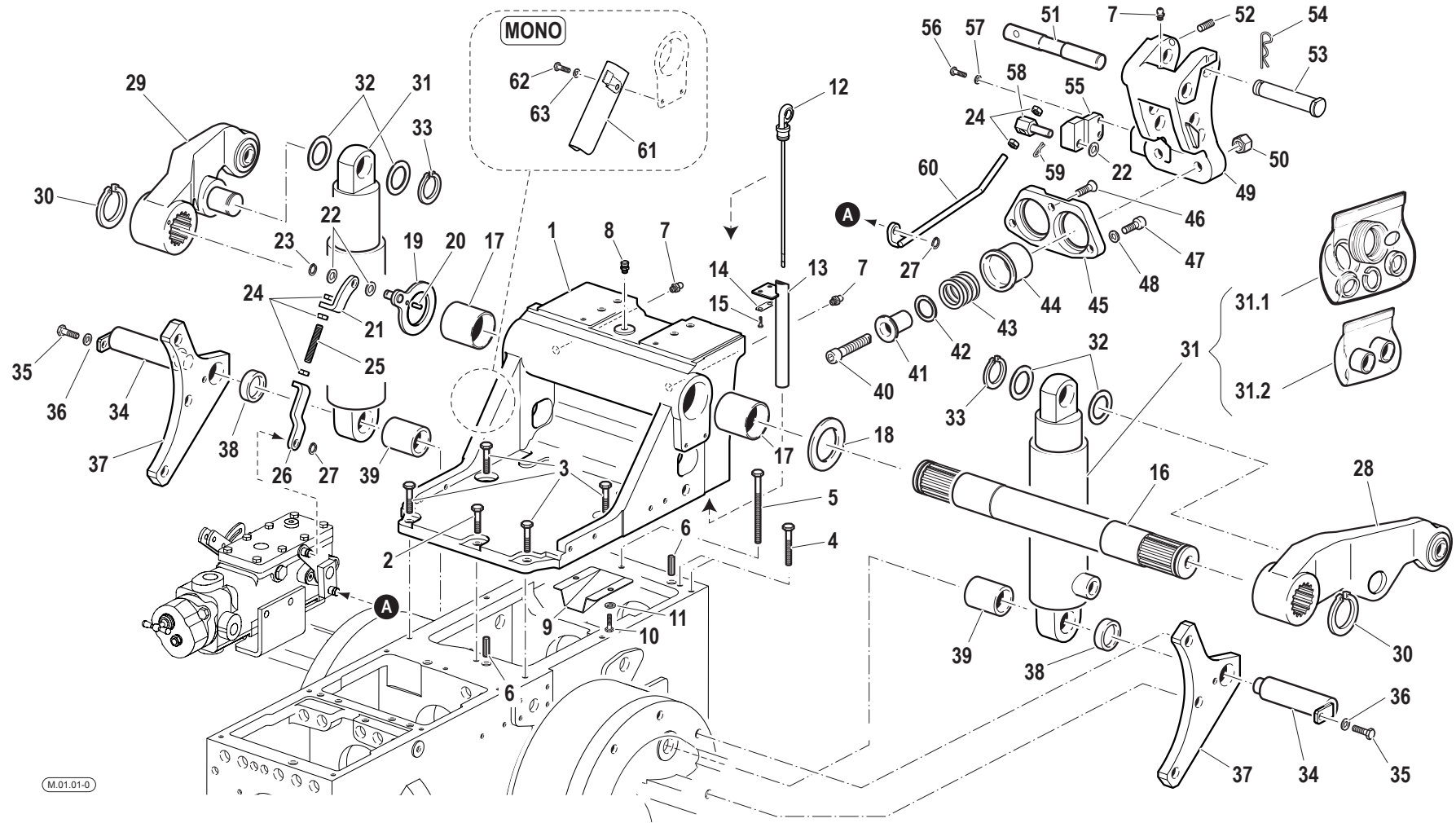

Pos.	Code	Q.ty	Description	Notes
1	51174047	1	SUPPORT	
10	31112149	2	SCREW TE M8X12 UNI 5739 8G	
11	F0843643060	2	WASHER 8	
12	58174581	1	OIL LEVEL ROD	
13	59076085	1	OIL PIPE	
14	52071702	1	CLAMPING PLATE	
15	31112082	2	SCREW TE M6X12 UNI 5739 8G	
16	56570284	1	SHAFT	
17	58170291	2	BUSHING	
18	56370288	1	SHIM	
19	59075148	1	SHIM	
2	31112219	1	SCREW TE M10X25 UNI 5739	
20	56570506	1	PIN	
21	56375147	1	BRACKET	
22	31411104	3	WASHER 10,5x18	
23	F0801050000	1	SEEGER RING E 10 UNI 7435	
24	F0814569000	5	NUT M8 UNI 5589 CL:8	
25	56375146	1	GRAIN	
26	56075145	1	BRACKET	
27	35211070	2	SEEGER RING E 7 UNI 7434	
28	59070289	1	LIFTING ARM	
29	59070290	1	RIGHT ARM	
3	31112211	4	SCREW TE M10X30 UNI 5739	
30	F0801331050	2	SEEGER RING E 45 UNI 7436	
31	58170245	2	LIFTING CYLINDER	
31.1	58171537	1	GASKET SET	
31.2	58171536	1	BUSHINGS KIT	
32	56370282	4	SHIM	
33	F0801241010	2	SEEGER RING E 30 UNI 7436	
34	56370287	2	HINGE PIN	
35	31112150	2	SCREW TE M8X20 UNI 5739 8G	
36	F0843643060	2	WASHER 8	
37	56170283	2	BRACKET	
38	56170286	2	SPACER	

SERIAL

POSITION AND DRAFT CONTROL LIFT

CODE REV

M.01.01_0_41199

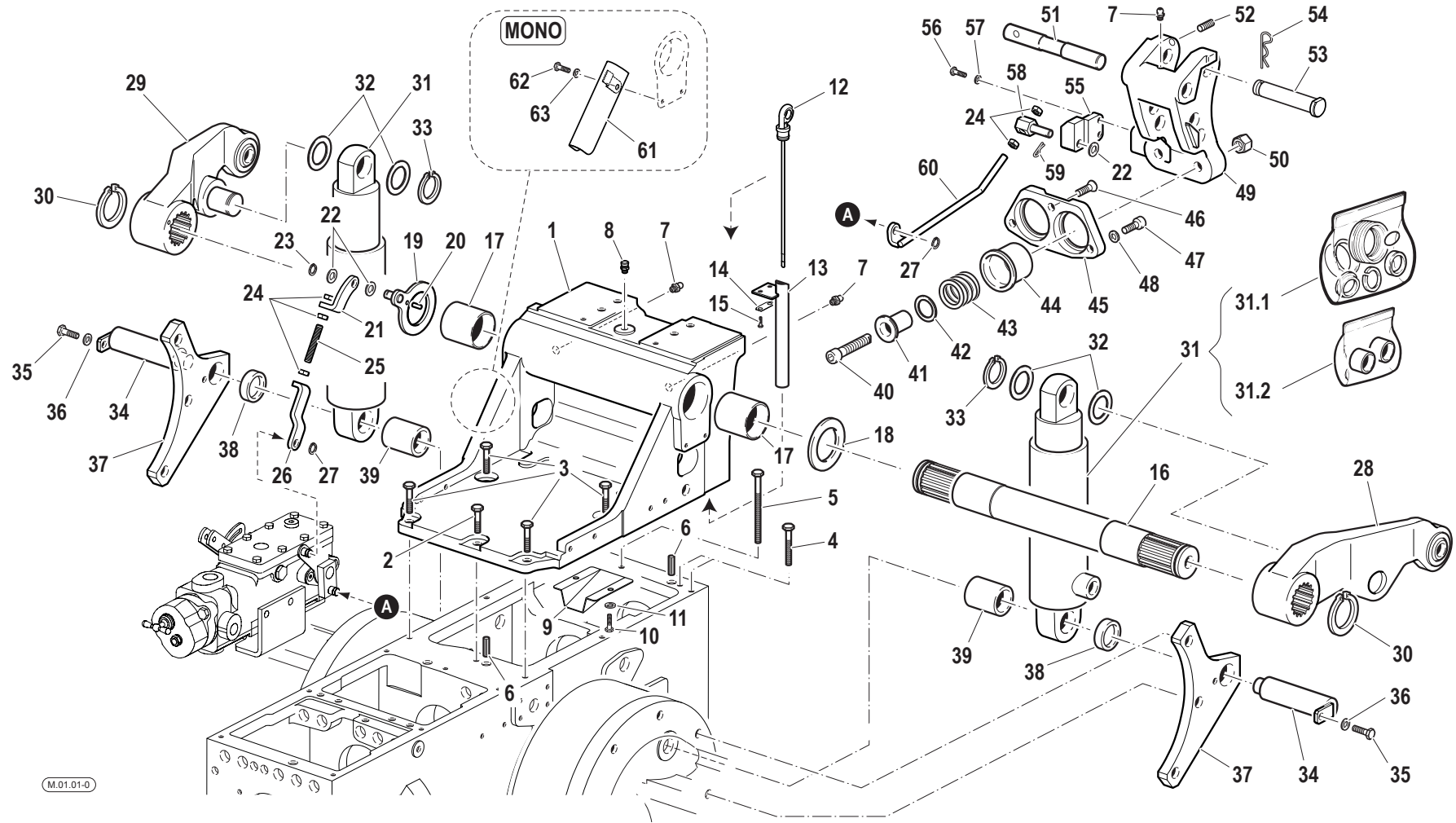

Pos.	Code	Q.ty	Description	Notes
39	56170285	2	SPACER	
4	F0863429000	4	SCREW M10X45 UNI 5737	
40	50973415	2	SCREW	
41	56073414	2	GUIDE	
42	56373426	1	SHIM	
42	56373427	1	SHIM	
42	56373428	1	SHIM	
42	58025869	1	SHIM	
43	58073411	2	SPRING	
44	56073413	2	SLEEVE	
45	56073416	1	FLANGE	
46	F0863208050	1	SCREW M10X20 UNI 5933	
47	31152097	2	SCREW TCEI M10X30 UNI 5931	
48	F0843755000	2	WASHER 10	
49	51173371	1	THREE-POINT LINKAGE	
5	31112217	1	SCREW TE M10X80 UNI 5737	
50	31241121	2	SELFLOCK NUT M12	
51	56374574	1	CONNECTING BOLT	
52	F0862593050	1	SCREW M8X20 UNI 5927	
53	56373436	1	PIN	
54	F0851486000	1	SPLIT PIN	
55	59075140	1	SMALL BLOCK	
56	31112093	2	SCREW TE M6X20 UNI 5739 8G	
57	F0843570000	2	WASHER 6	
58	56075143	1	HINGE PIN	
59	34110030	1	SPLIT PIN	
6	56570016	2	CYLINDRICAL PLUG	
60	59075137	1	ROD	
61	59075178	1	CABLE BARRIER RAIL	
62	31111091	1	SCREW E M6X14 UNI 5739 8G	
63	F0843570000	1	WASHER 6	
7	F0826056000	3	LUBRICATOR M10 UNI 7663A	
8	58075603	1	PLUG	
9	56173638	1	GUARD	

SERIAL

POSITION AND DRAFT CONTROL LIFT

CODE REV

M.01.01_0_41199

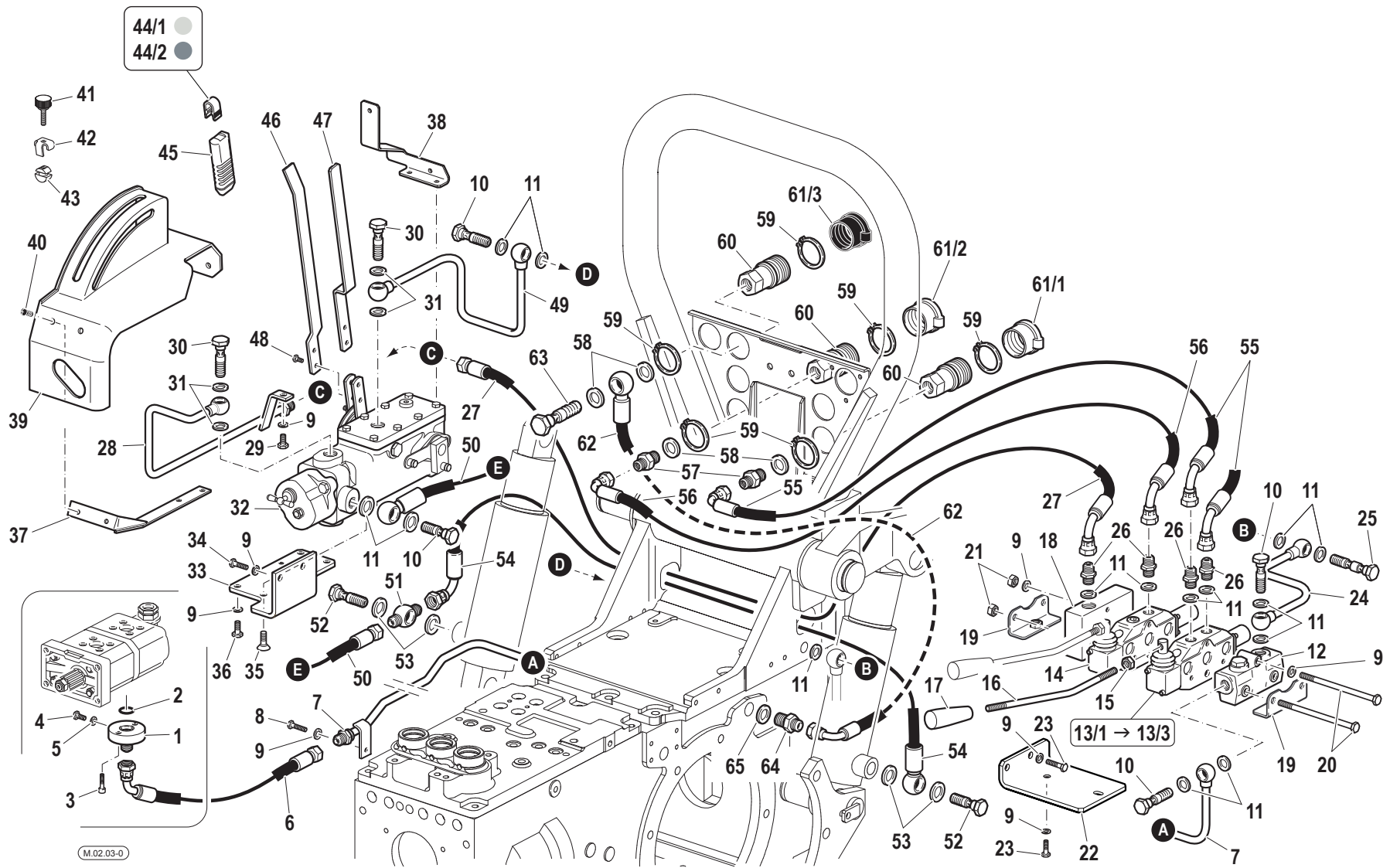

Pos.	Code	Q.ty	Description	Notes
1	F0825809000	1	PRESSURE PIPE CONNECTOR	
10	F0843109020	4	PIPE FITTING	
11	F0824110000	15	COPPER WASHER 3/8 GAS	
12	58172304	1	HEAD	
13/1	58172012	1	D.A. VALVE	
13/2	58172013	1	D.A. VALVE	
13/3	58172014	1	D.A. VALVE	
14	58172011	1	S.A. VALVE	
15	31211100	2	NUT M10	
16	56170964	2	COMMAND LEVER	
17	F0837534010	2	GRIP	
18	58173361	1	COVER	
19	59072057	2	FIXING BRACKET	
2	F0803185000	1	O-RING 3068 (17,12x2,62)	
20	58172016	3	ROD	
21	31211080	3	NUT M8	
22	56174201	1	LEFT BRACKET	
23	31112150	4	SCREW TE M8X20 UNI 5739 8G	
24	59075039	1	EXHAUST	
25	F0843110010	1	THREADED TERMINAL END M18x1,5	
26	30000197	4	NIPPLE	
27	58075159	1	FLEXIBLE HOSE	
28	59075979	1	PRESSURE PIPE	
29	31112149	1	SCREW TE M8X12 UNI 5739 8G	
3	31152057	2	SCREW TCEI M6X16 UNI 5931	
30	F0843116000	2	PIPE FITTING 1/2	
31	F0824141000	4	COPPER WASHER 21x27/1,5	
32	58175191	1	DISTRIBUTOR	
33	56075161	1	FIXING BRACKET	
34	31112150	2	SCREW TE M8X20 UNI 5739 8G	
35	F0862481000	1	SCREW M8x16 UNI 5933	
36	31111151	3	SCREW TE M8X16 UNI 5739 8G	
37	59075254	1	FIXING BRACKET	
38	56075252	1	FIXING BRACKET	

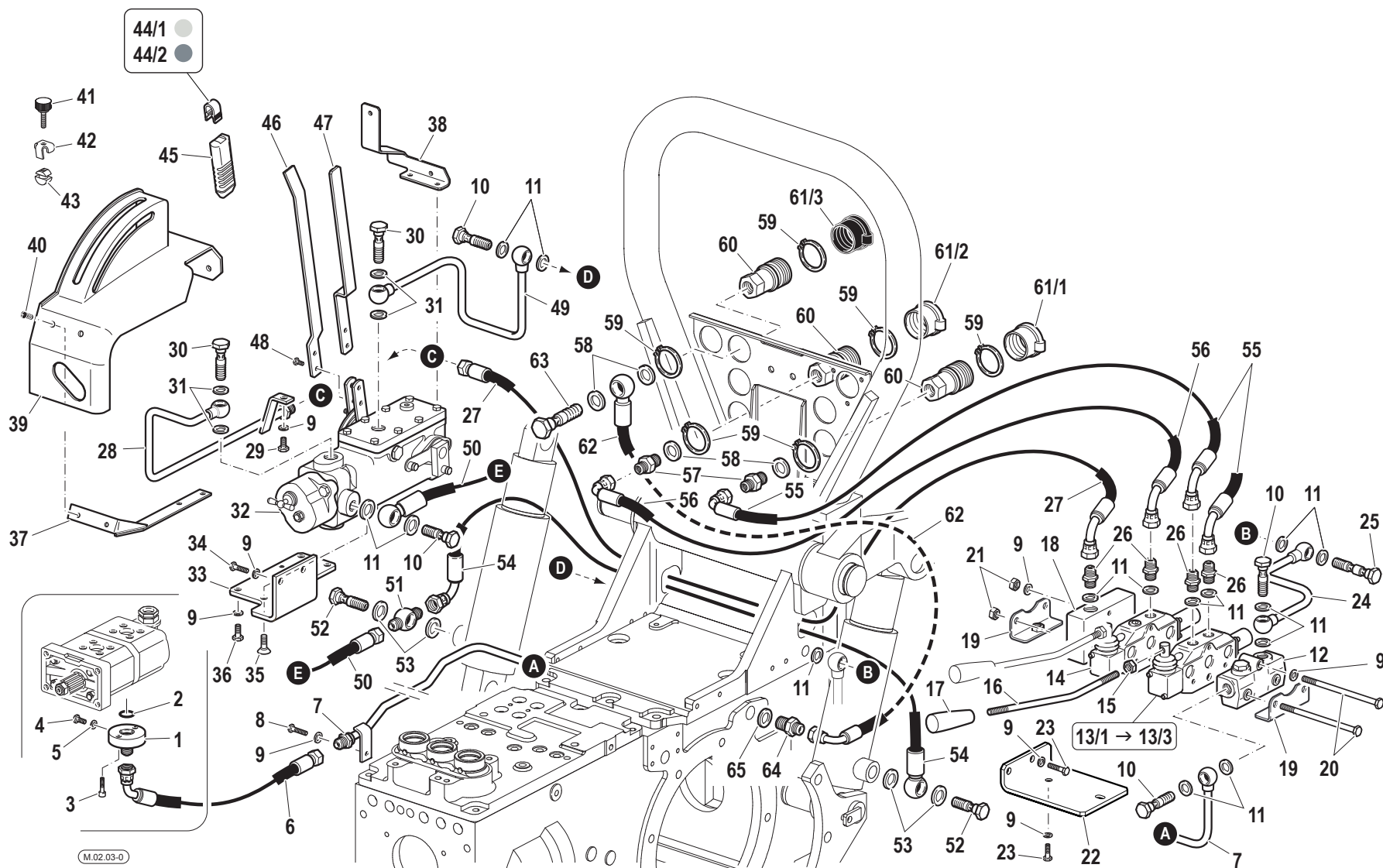

M.02.03-0

Pos.	Code	Q.ty	Description	Notes
39	57375195	1	COVER	
4	F0862462010	1	SCREW M8X1/12 UNI5740	
40	F0861973000	4	SCREW M6X10 COMBI	
41	58177761	1	KNOB	
42	56075197	1	CLIP	
43	56077760	1	SMALL BLOCK	
44/1	58175211	1	INSERT	
44/2	58175188	1	INSERT	
45	58175187	2	KNOB	
46	56075185	1	COMMAND LEVER	
47	56075186	1	COMMAND LEVER	
48	31112090	4	SCREW TE M6X16 UNI 5739 8G	
49	59075171	1	EXHAUST	
5	F0824022000	1	SPECIAL GASKET D.8,4X12/1	
50	58075160	1	FLEXIBLE HOSE	
51	58170512	1	EYELET	
52	F0843110010	2	THREADED TERMINAL END M18x1,5	
53	F0824113000	4	COPPER WASHER 18X24/1,5	
54	58070513	1	FLEXIBLE HOSE	
55	58074958	2	FLEXIBLE HOSE	
56	58075226	1	FLEXIBLE HOSE	
57	F0835037000	3	NIPPLE	
58	F0824141000	5	COPPER WASHER 21x27/1,5	
59	F0801282000	8	SEEGER RING E 38 UNI 7435	
6	58075247	1	FLEXIBLE HOSE	
60	F0825980030	4	COUPLING	
61/1	F0852550020	2	GUARD	
61/2	F0852550030	1	GUARD	
61/3	F0852550040	1	GUARD	
62	58075082	1	FLEXIBLE HOSE	
63	F0843116000	1	PIPE FITTING 1/2	
64	58175083	1	NIPPLE	
65	F0844273090	1	GASKET 22X28X1,5 CU 99,5	
7	59075169	1	PRESSURE PIPE	

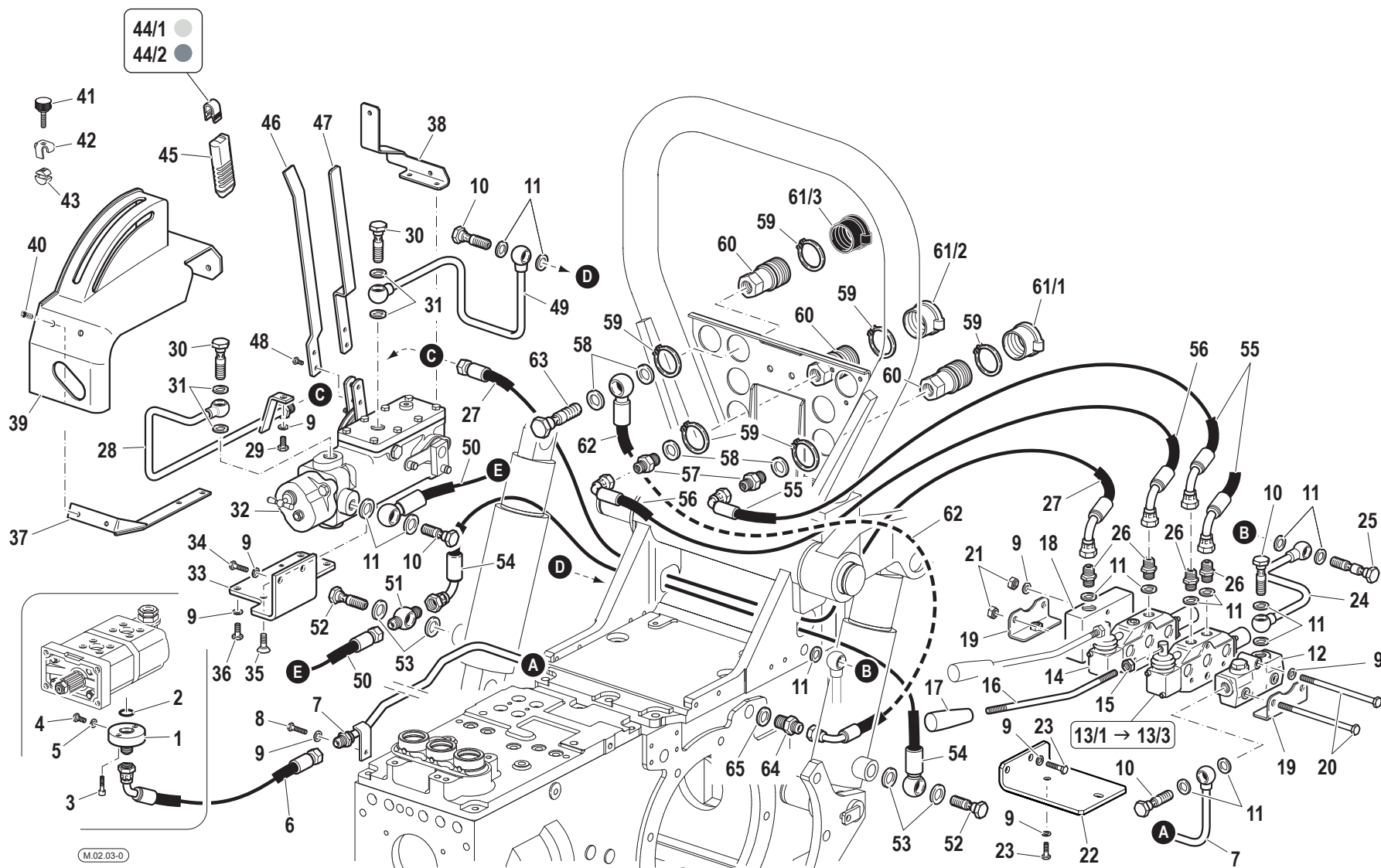

Pos.	Code	Q.ty	Description	Notes
8	31111151	1	SCREW TE M8X16 UNI 5739 8G	
9	F0843643060	14	WASHER 8	

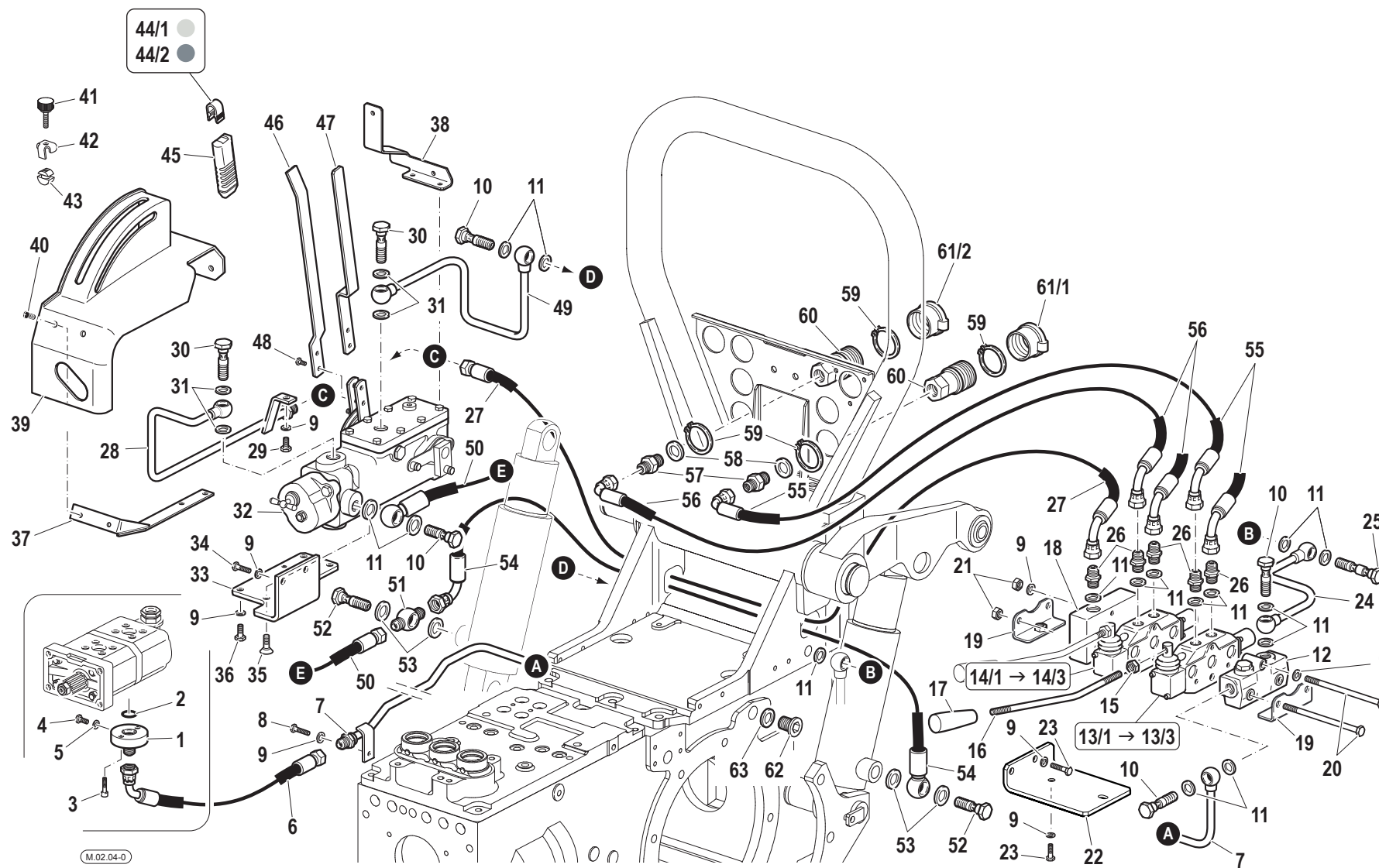

Pos.	Code	Q.ty	Description	Notes
1	F0825809000	1	PRESSURE PIPE CONNECTOR	
10	F0843109020	4	PIPE FITTING	
11	F0824110000	15	COPPER WASHER 3/8 GAS	
12	58172304	1	HEAD	
13/1	58172012	1	D.A. VALVE	
13/2	58172013	1	D.A. VALVE	
13/3	58172014	1	D.A. VALVE	
14/1	58172012	1	D.A. VALVE	
14/2	58172013	1	D.A. VALVE	
14/3	58172014	1	D.A. VALVE	
15	31211100	2	NUT M10	
16	56170964	2	COMMAND LEVER	
17	F0837534010	2	GRIP	
18	58173361	1	COVER	
19	59072057	2	FIXING BRACKET	
2	F0803185000	1	O-RING 3068 (17,12x2,62)	
20	58172016	3	ROD	
21	31211080	3	NUT M8	
22	56174201	1	LEFT BRACKET	
23	31112150	4	SCREW TE M8X20 UNI 5739 8G	
24	59075039	1	EXHAUST	
25	F0843110010	1	THREADED TERMINAL END M18x1,5	
26	30000197	4	NIPPLE	
27	58075159	1	FLEXIBLE HOSE	
28	59075979	1	PRESSURE PIPE	
29	31112149	1	SCREW TE M8X12 UNI 5739 8G	
3	31152057	2	SCREW TCEI M6X16 UNI 5931	
30	F0843116000	2	PIPE FITTING 1/2	
31	F0824141000	4	COPPER WASHER 21x27/1,5	
32	58175191	1	DISTRIBUTOR	
33	56075161	1	FIXING BRACKET	
34	31112150	2	SCREW TE M8X20 UNI 5739 8G	
35	F0862481000	1	SCREW M8x16 UNI 5933	
36	31111151	3	SCREW TE M8X16 UNI 5739 8G	

SERIAL

CONTROL VALVES WITHOUT FREE DISCHARGE VERSION

CODE REV

M.02.04_0_41480

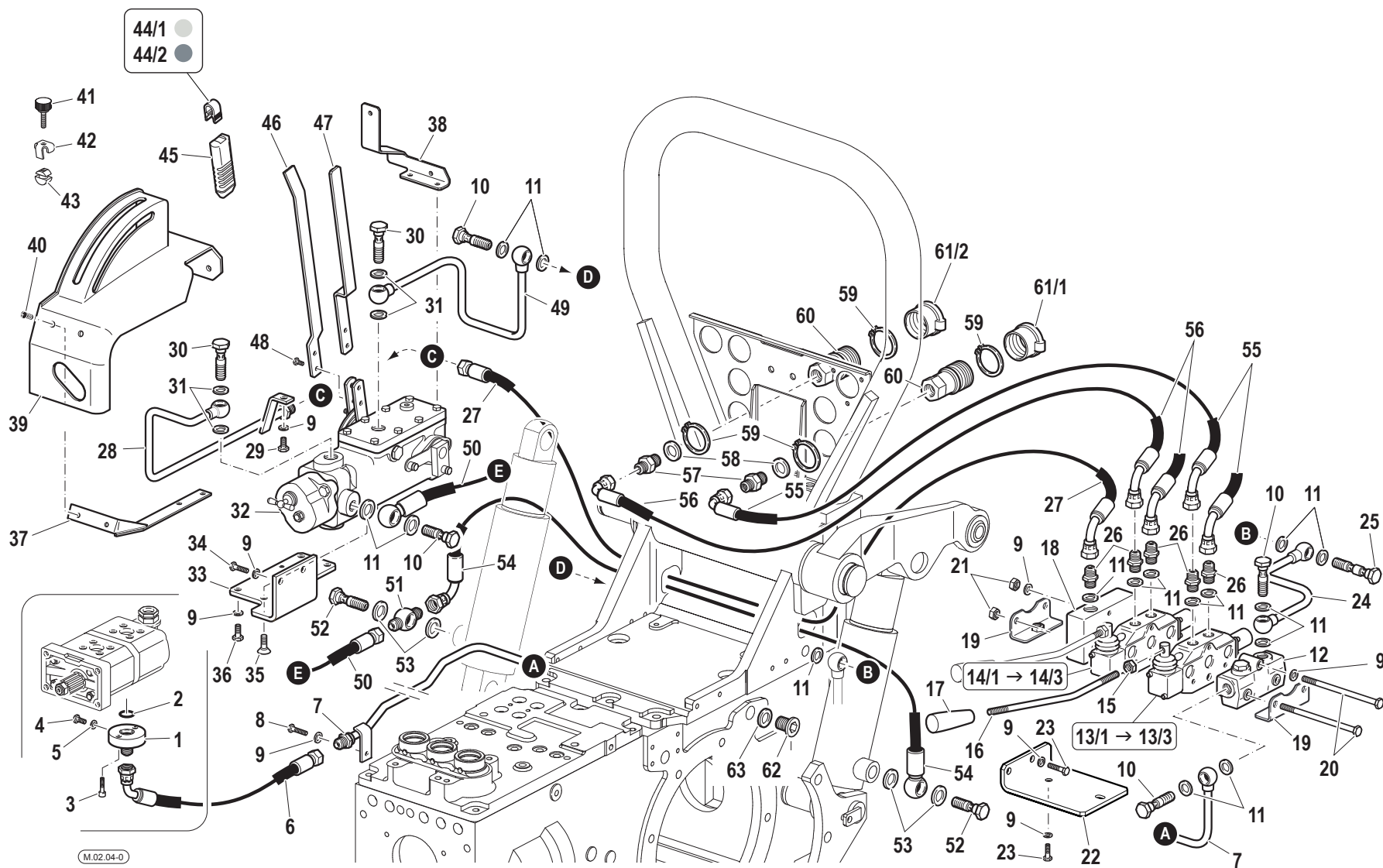

Pos.	Code	Q.ty	Description	Notes
37	59075254	1	FIXING BRACKET	
38	56075252	1	FIXING BRACKET	
39	57375195	1	COVER	
4	F0862462010	1	SCREW M8X1/12 UNI5740	
40	F0861973000	4	SCREW M6X10 COMBI	
41	58177761	1	KNOB	
42	56075197	1	CLIP	
43	56077760	1	SMALL BLOCK	
44/1	58175211	1	INSERT	
44/2	58175188	1	INSERT	
45	58175187	2	KNOB	
46	56075185	1	COMMAND LEVER	
47	56075186	1	COMMAND LEVER	
48	31112090	4	SCREW TE M6X16 UNI 5739 8G	
49	59075171	1	EXHAUST	
5	F0824022000	1	SPECIAL GASKET D.8,4X12/1	
50	58075160	1	FLEXIBLE HOSE	
51	58170512	1	EYELET	
52	F0843110010	2	THREADED TERMINAL END M18x1,5	
53	F0824113000	4	COPPER WASHER 18X24/1,5	
54	58070513	1	FLEXIBLE HOSE	
55	58074958	2	FLEXIBLE HOSE	
56	58075226	1	FLEXIBLE HOSE	
57	F0835037000	3	NIPPLE	
58	F0824141000	3	COPPER WASHER 21x27/1,5	
59	F0801282000	6	SEEGER RING E 38 UNI 7435	
6	58075247	1	FLEXIBLE HOSE	
60	F0825980030	3	COUPLING	
61/1	F0852550020	2	GUARD	
61/2	F0852550030	1	GUARD	
62	56370081	1	PLUG	
63	F0844273090	1	GASKET 22X28X1,5 CU 99,5	
7	59075169	1	PRESSURE PIPE	
8	31111151	1	SCREW TE M8X16 UNI 5739 8G	

SERIAL

CONTROL VALVES WITHOUT FREE DISCHARGE VERSION

CODE REV

M.02.04_0_41480

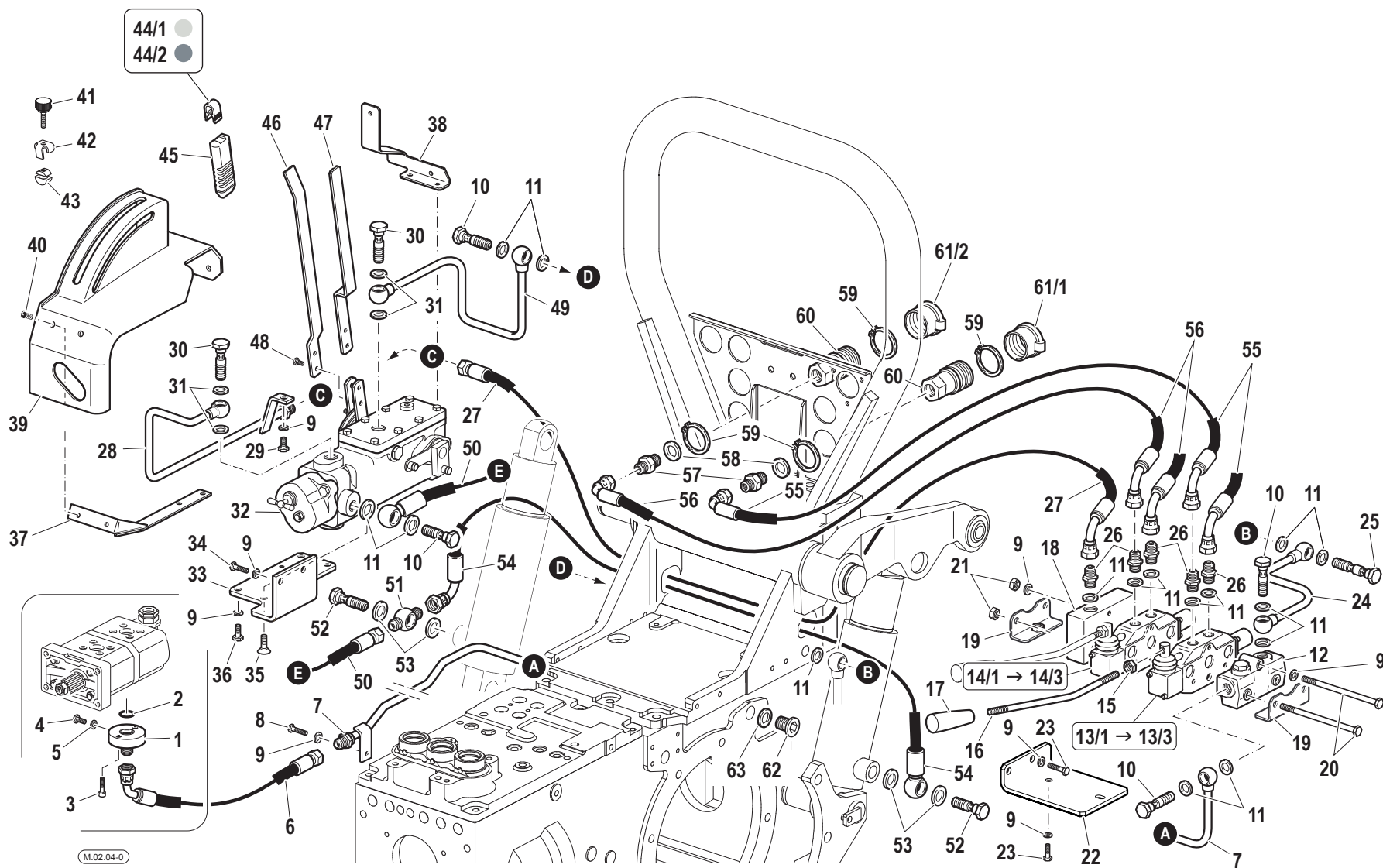

Pos.	Code	Q.ty	Description	Notes
9	F0843643060	14	WASHER 8	

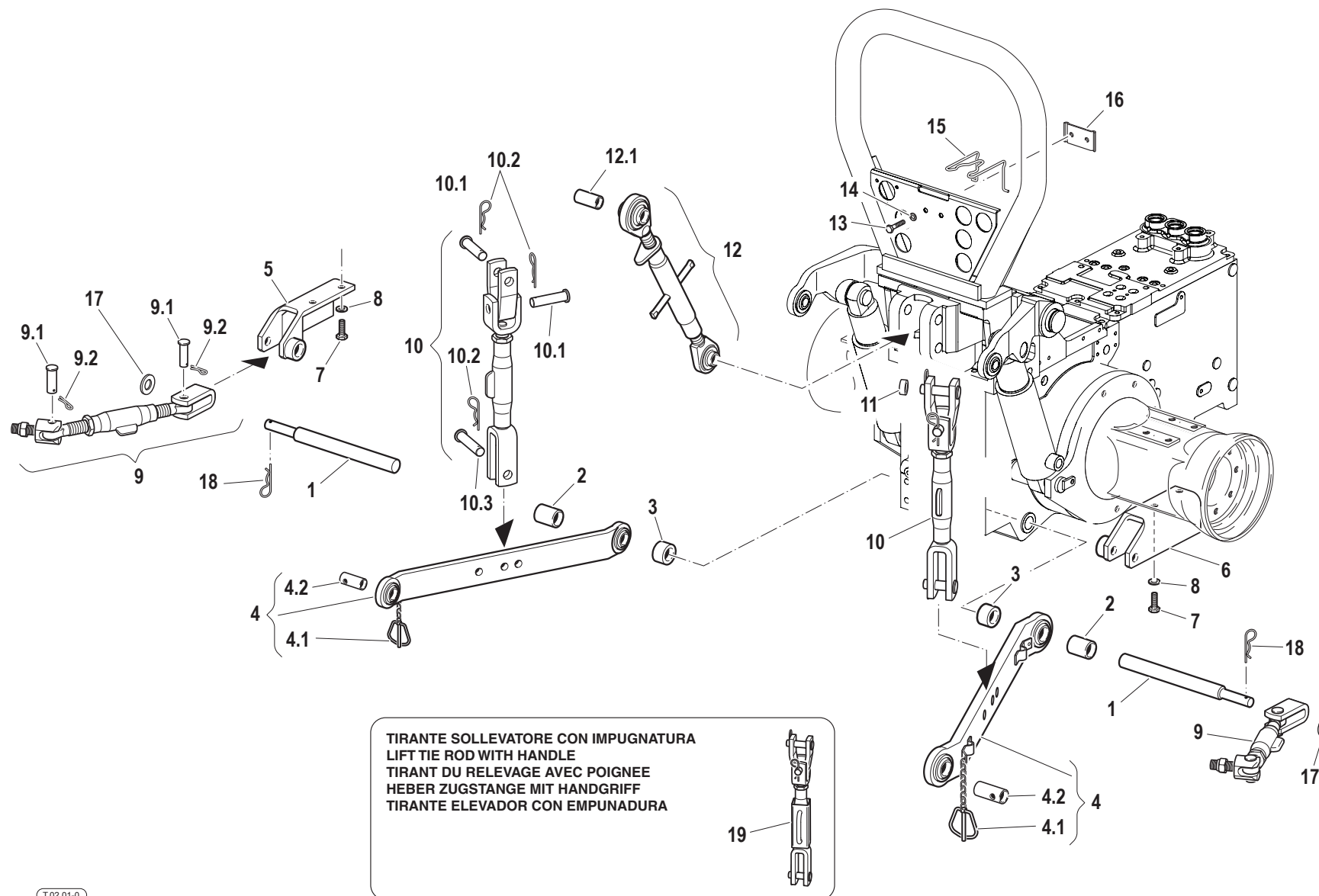

Pos.	Code	Q.ty	Description	Notes
1	56577772	2	PIN	
10	58077205	2	ROD	
10.1	58071755	2	PIN	
10.2	F0851486000	3	SPLIT PIN	
10.3	58070482	1	PIN	
11	58071757	2	WASHER D.33x19,5/8	
12	58075983	1	3-POINT HITCH	
12.1	56073059	1	REDUCING BUSH	
13	31112150	2	SCREW TE M8X20 UNI 5739 8G	
14	F0843643060	2	WASHER 8	
15	58170449	1	RETAINING SPRING	
16	59070448	1	FIXING BRACKET	
17	31411170	2	WASHER 17x30	
18	34130010	2	SPLIT PIN	
19	58077202	2	ROD	
2	56077774	2	SPACER	
3	56170392	2	SPACER	
4	58071322	2	BOTTOM LINK	
4.1	F0852107050	1	PISTON PIN	
4.2	58171021	1	REDUCING BUSH	
5	59075791	1	SUPPORT	
6	59075840	1	SUPPORT	
7	31112272	4	SCREW TE M12X30 UNI 5739	
8	F0843843060	4	WASHER 12	
9	58076355	2	ROD	
9.1	58070480	2	PIN	
9.2	34110029	2	SPLIT PIN	

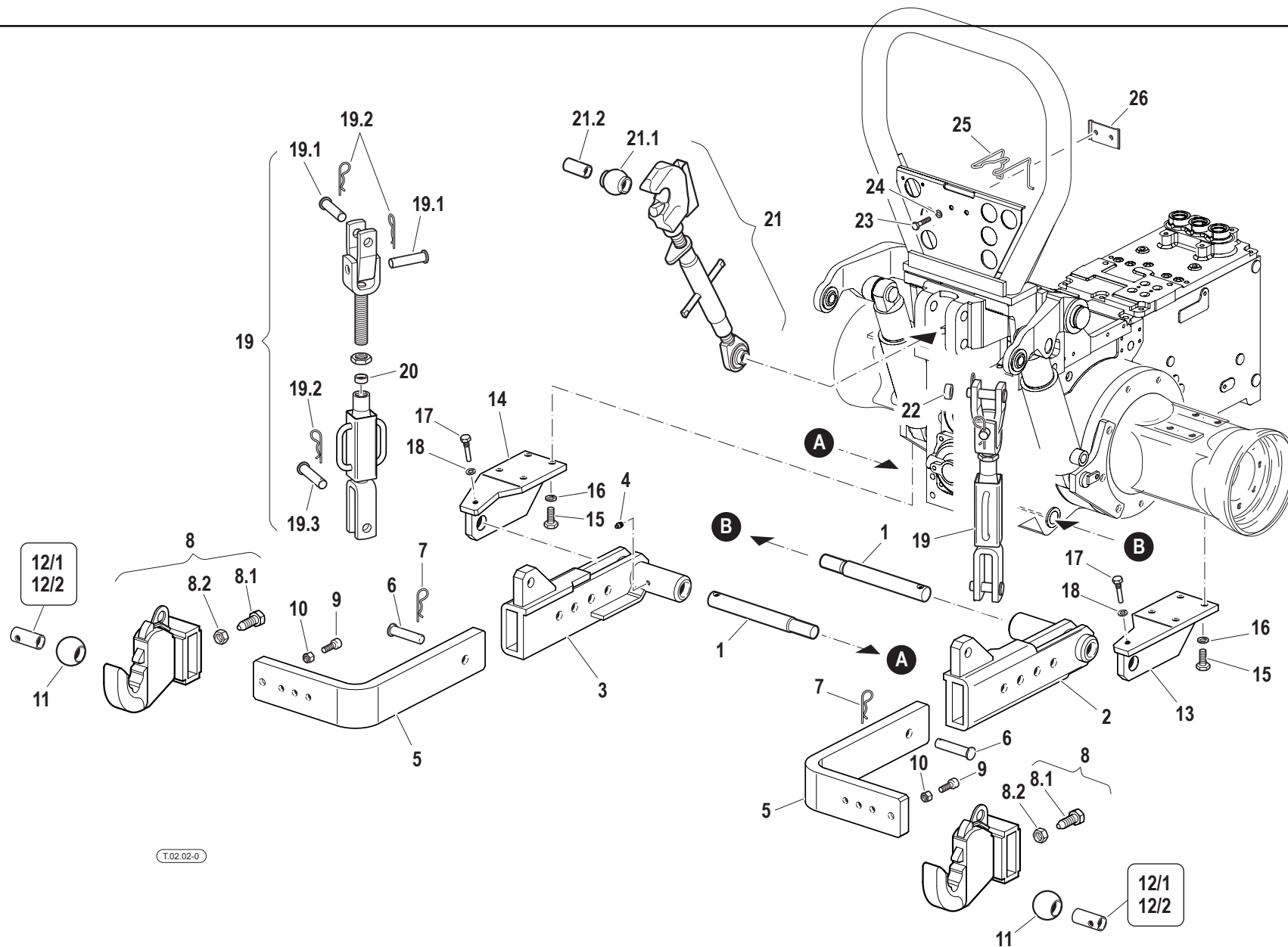

Pos.	Code	Q.ty	Description	Notes
1	56575035	2	PIN	
10	31211100	2	NUT M10	
11	58171000	2	JOINT	
12/1	58171021	2	REDUCING BUSH	
12/2	58177978	2	BUSHING	
13	59075850	1	SUPPORT	
14	59075885	1	SUPPORT	
15	31112272	4	SCREW TE M12X30 UNI 5739	
16	F0843843060	4	WASHER 12	
17	56075036	2	SCREW	
18	F0843755000	2	WASHER 10	
19	58077325	2	ROD	
19.1	58071755	2	PIN	
19.2	F0851486000	4	SPLIT PIN	
19.3	58070482	2	PIN	
2	59079186	1	HOLDER	
20	56177671	2	SPACER	
21	58075987	1	3-POINT HITCH	
21.1	58173072	1	JOINT	
21.2	56073059	1	REDUCING BUSH	
22	58071757	2	WASHER D.33x19,5/8	
23	31112150	2	SCREW TE M8X20 UNI 5739 8G	
24	F0843643060	2	WASHER 8	
25	58170449	1	RETAINING SPRING	
26	59070448	1	FIXING BRACKET	
3	59079187	1	HOLDER	
4	F0826056000	2	LUBRICATOR M10 UNI 7663A	
5	56175848	2	ARM	
6	56375954	4	PIN	
7	F0851486000	4	SPLIT PIN	
8	59076100	2	DEVICE COUPLING	
8.1	56275953	1	SCREW	
8.2	31211200	1	NUT M20	
9	F0863302000	2	SCREW M10X30 UNI 5931	

SERIAL

IMPLEMENTS ATTACHMENT - ADJUSTABLE ARMS WITH QUICK HITCHES

CODE REV

T.02.02_0_41675

PULL HOOK - STANDARD

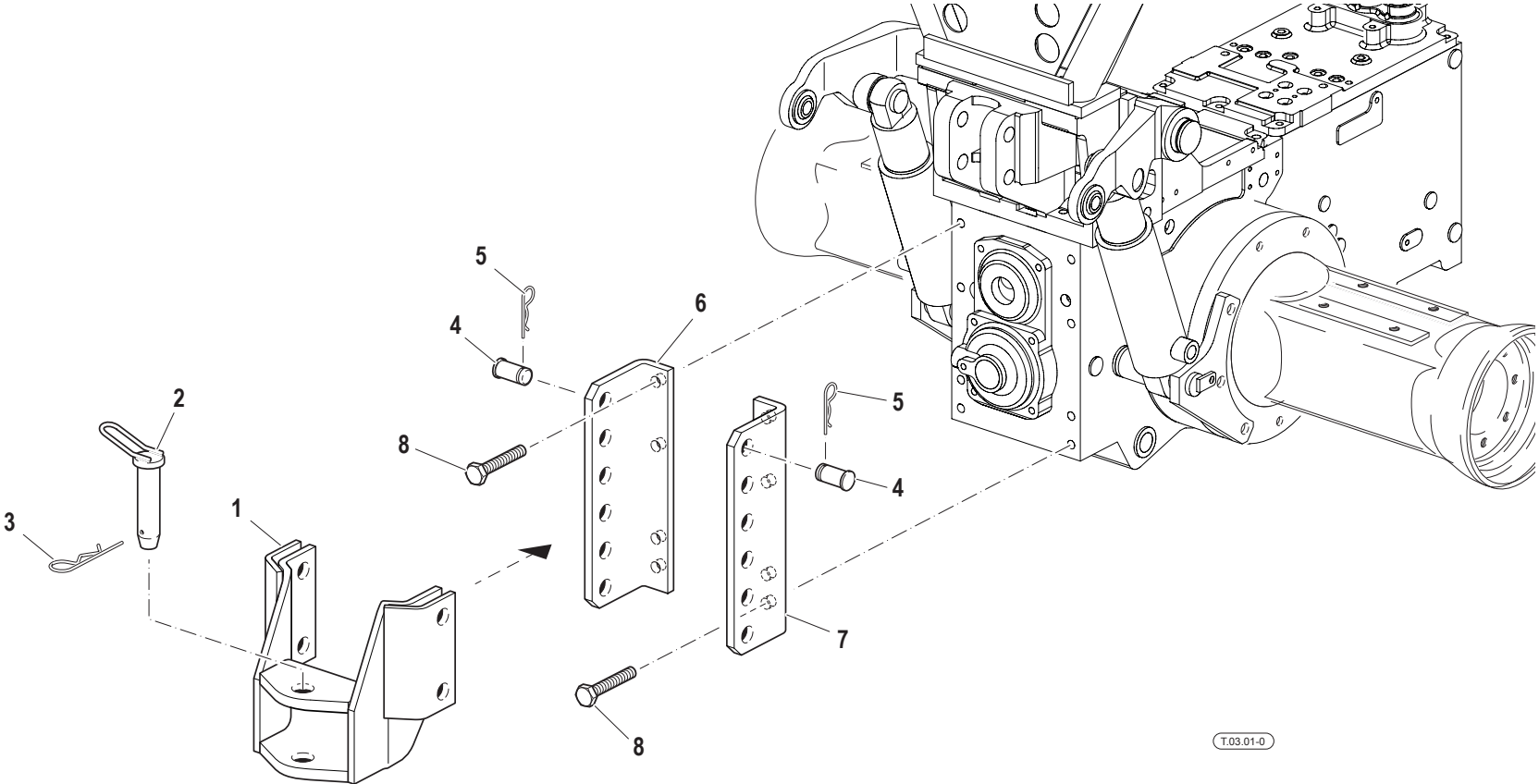

T.03.01-0

Pos.	Code	Q.ty	Description	Notes
1	59070702	1	TOW HOOK	
2	F0808060100	1	LATCH D.28X117	
3	F0851497000	1	SPLIT PIN	
4	56370696	4	PIN	
5	F0851486000	4	SPLIT PIN	
6	56170704	1	SUPPORT	
7	56170705	1	SUPPORT	
8	F0864180000	8	SCREW M14X30 UNI 5740	

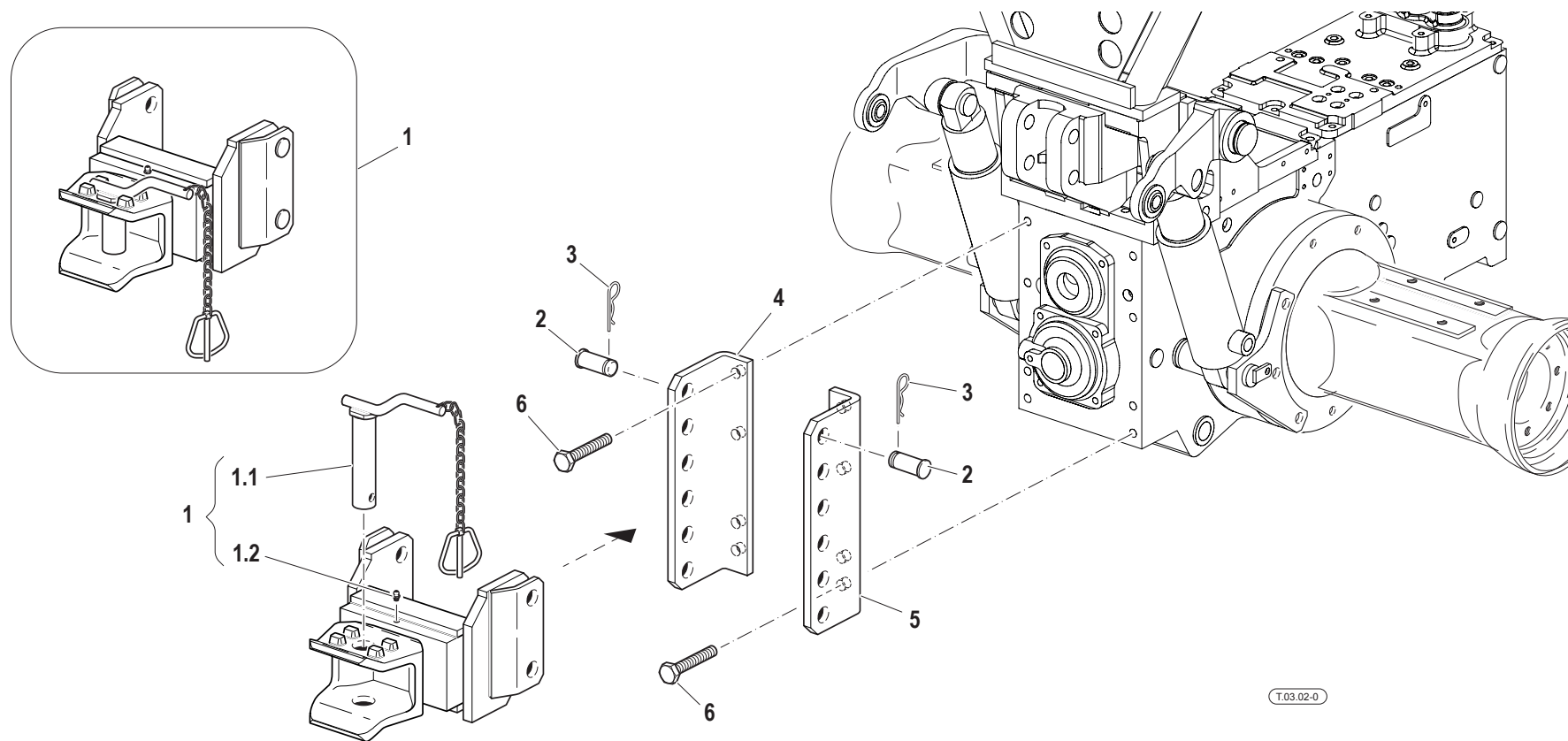

Pos.	Code	Q.ty	Description	Notes
1	59375009	1	TOW HOOK	
1.1	59075012	1	PIN	
1.2	F0826056000	1	LUBRICATOR M10 UNI 7663A	
2	56375008	4	PIN	
3	F0851486000	4	SPLIT PIN	
4	56170704	1	SUPPORT	
5	56170705	1	SUPPORT	
6	F0864180000	8	SCREW M14X30 UNI 5740	

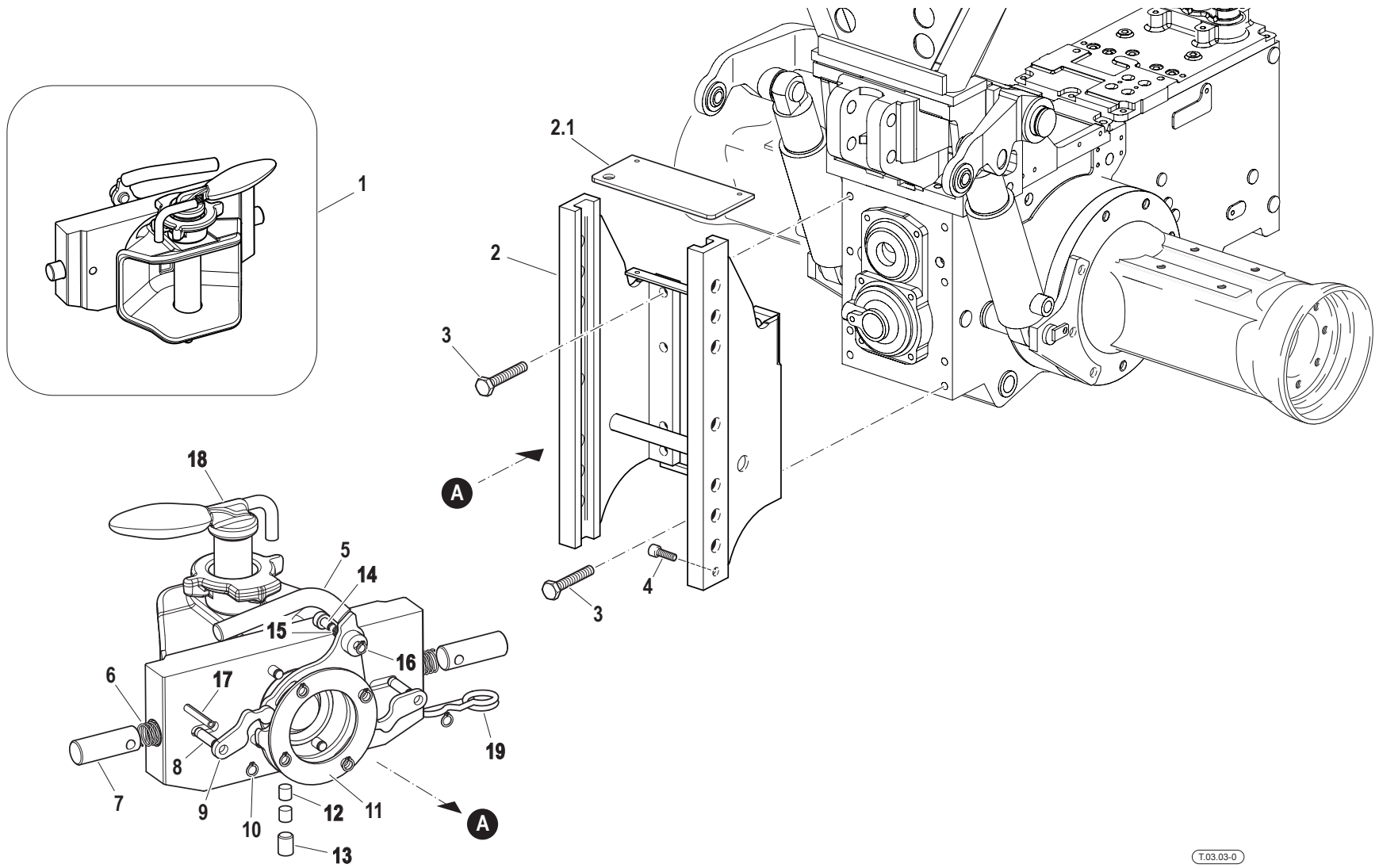

Pos.	Code	Q.ty	Description	Notes
1	59377734	1	CLEVIS	
10	F0801028000	6	SEEGER RING E 8 UNI 7435	
11	58177741	1	DISC	
12	58177742	2	PAD	
13	F0863672010	1	SCREW	
14	58177743	1	PIN	
15	58177744	1	SPRING	
16	F0801022000	1	SEEGER RING E 7 UNI 7435	
17	34211064	1	ROLL PIN	
18	58177745	1	PIN	
19	58177746	1	SPLIT PIN	
2	59377730	1	CHASSIS FRAME	
2.1	58177732	1	GUARD	
3	F0864222010	8	SCREW M14X1,5/40 5738	
4	31152103	2	SCREW TCEI M10X25 UNI 5931	
5	58177736	1	LEVA SBLO.COMP.(81.0121.01.03)	
6	58177737	2	SPRING	
7	58177738	2	PIN	
8	58177739	6	PIN	
9	58177740	2	CONNECTING ROD	

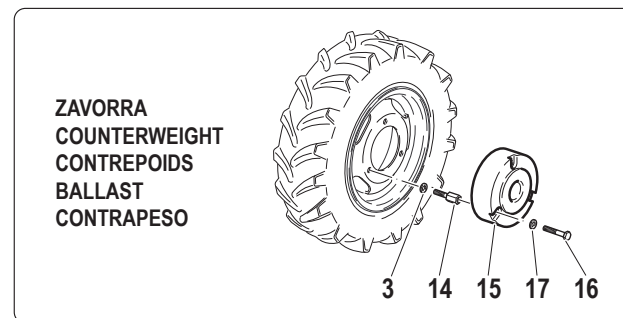
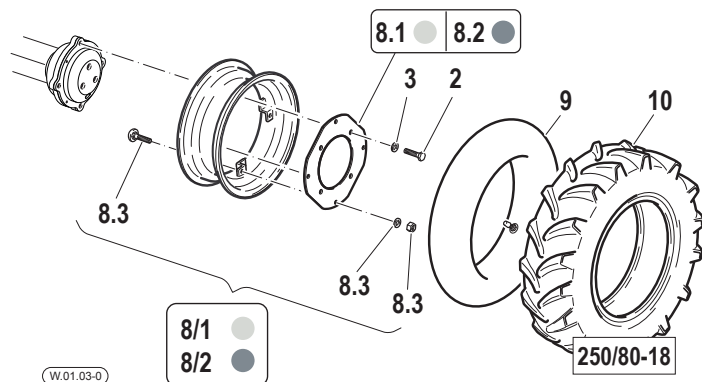
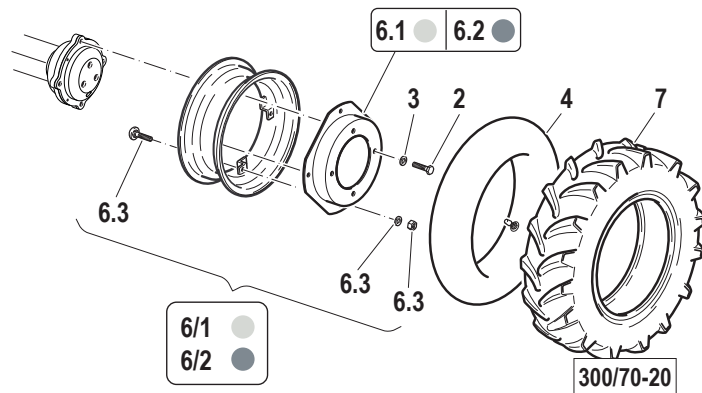
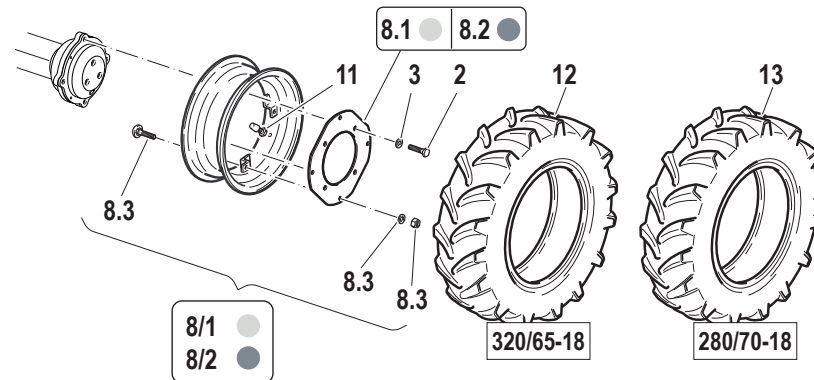
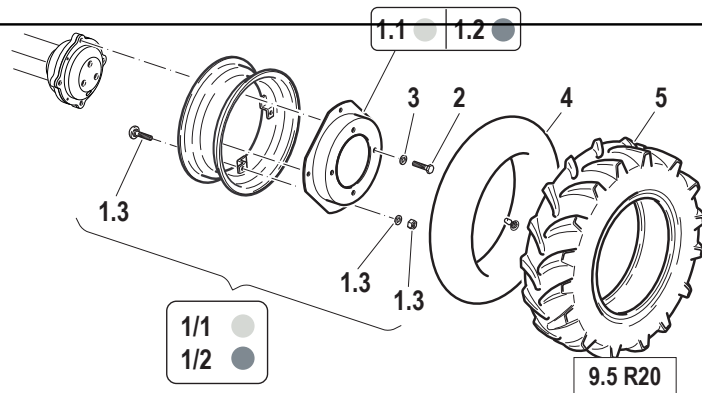

Pos.	Code	Q.ty	Description	Notes
1.1	58170181	1	DISC	
1.2	58175965	1	DISC	
1.3	59900361	1	KIT	
1/1	59270304	1	RIM	
1/2	59273925	1	RIM	
10	F0848655000	1	TYRE 250/80-18 8PR	
11	F0150010905	1	VALVE	
12	F0848679600	1	TYRE 320/65R18	
13	F0848655100	1	TYRE 280/70R18	
14	56370539	4	SPECIAL SCREW	
15	51177257	1	BALLAST	
16	F0864314000	4	SCREW M14X65 UNI 5737	
17	F0843993060	4	WASHER 28x15/4	
2	F0864410500	4	SCREW M18X1,5/45 U/5740	
3	F0844150000	4	WASHER D.30x18,5/5	
4	F0848920000	1	INNER TUBE	
5	F0848664000	1	TYRE 9.5-R20	
6.1	58176323	1	FLANGIA CERCHIO W10X20 RAL1003	
6.2	58176324	1	FLANGIA CERCHIO W10X20 RAL9006	
6.3	59900361	1	KIT	
6/1	59276320	1	RIM	
6/2	59276321	1	RIM	
7	F0848676050	1	TYRE 300/70 R20	
8.1	58175630	1	RIM	
8.2	58175966	1	RIM	
8.3	59900361	1	KIT	
8/1	59275632	1	RIM	
8/2	59275633	1	RIM	
9	F0848855000	1	INNER TUBE	

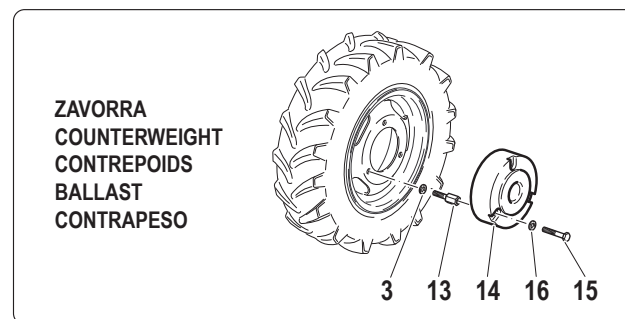
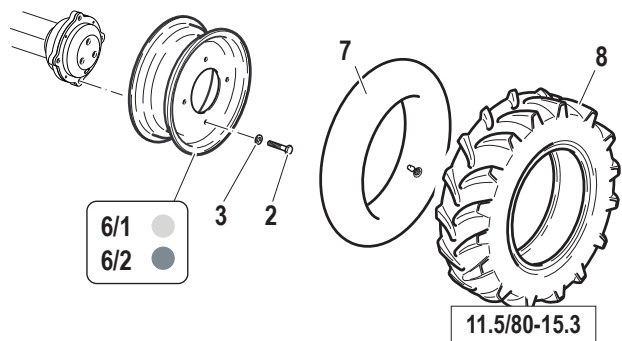
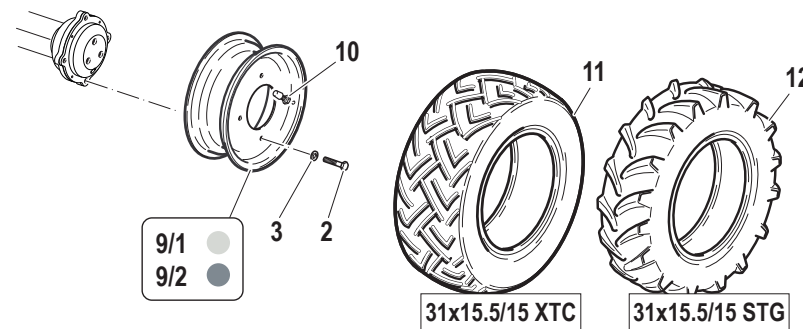
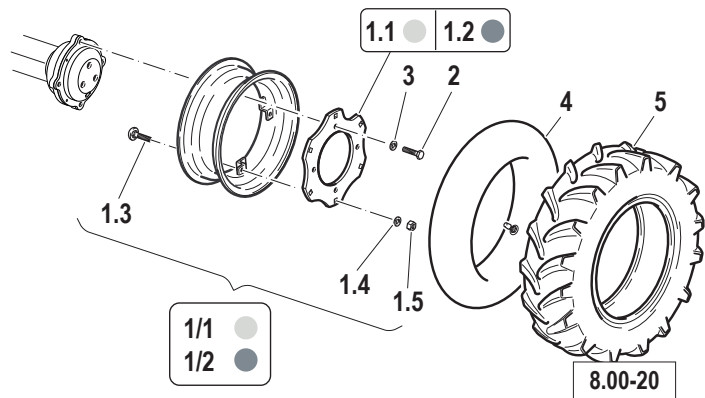

Pos.	Code	Q.ty	Description	Notes
1.1	56177416	1	DISCO CERCHIO 5,50X20 RAL 1003	
1.2	56177417	1	DISCO CERCHIO 5,50X20 RAL 9006	
1.3	F0864357100	5	SCREW M16x1,5x120 UNI5731	
1.4	F0844084000	5	WASHER D.35x17/4	
1.5	31221161	5	NUT M16X1,5	
1/1	59277415	1	RIM	
1/2	59277414	1	RIM	
10	F0150010905	1	VALVE	
11	F0848681600	1	TYRE 31X15.5-15 8PR	
12	F0848681605	1	TYRE 31X15.5-15	
13	56370539	4	SPECIAL SCREW	
14	51177257	1	BALLAST	
15	F0864314000	4	SCREW M14X65 UNI 5737	
16	F0843993060	4	WASHER 28x15/4	
2	F0864410500	4	SCREW M18X1,5/45 U/5740	
3	F0844150000	4	WASHER D.30x18,5/5	
4	F0848920000	1	INNER TUBE	
5	39118528	1	TYRE 8.00X20/8	
6/1	58176271	1	RIM	
6/2	58176272	1	RIM	
7	F0848844000	1	INNER TUBE	
8	F0848672100	1	TYRE 11.5/80-15.3 8PR	
9/1	58178571	1	RIM	
9/2	58178572	1	RIM	

SPARE PARTS INSTANCE INDEX



SPARE PARTS INSTANCE INDEX

Code	Parts Table	Pos.	Q.ty	Code	Parts Table	Pos.	Q.ty	Code	Parts Table	Pos.	Q.ty
28174882	A.03.01_0_45689	5	1	31111151	B.11.01_0_38871	41	4	31112090	C.01.02_0_39031	3	4
	A.03.02_0_45727	5	1		B.12.04_0_51054	10	5		F.02.01_0_51232	6	4
30000005	C.02.04_1_39212	8	1		C.02.04_0_39172	17	2		F.03.04_0_40779	38	1
30000007	C.02.04_1_39212	9	1		C.02.04_1_39212	17	2		F.03.04_1_40827	38	1
	D.03.02_0_39758	24	1		F.01.03_0_51164	16	4		M.02.03_0_41409	48	4
	D.03.02_1_39804	21	1		L.02.02_0_40987	8	1		M.02.04_0_41480	48	4
30000197	L.02.02_0_40987	31	6		L.02.05_0_41145	8	1	31112092	F.03.04_0_40779	7	2
	L.02.05_0_41145	32	7		M.02.03_0_41409	36	3		F.03.04_1_40827	7	2
	M.02.03_0_41409	26	4		M.02.03_0_41409	8	1	31112093	B.02.01_1_47161	24	8
	M.02.04_0_41480	26	4		M.02.04_0_41480	36	3		C.02.04_0_39172	30	4
30000506	E.03.02_0_42668	15	1		M.02.04_0_41480	8	1		C.02.04_1_39212	30	4
30000514	B.03.03_0_50588	26	1	31111156	D.01.02_0_40152	2/2	1		M.01.01_0_41199	56	2
30000614	B.08.02_0_38771	8	1	31111218	A.05.02_0_45864	14	2	31112096	A.05.02_0_45864	27	2
30000638	E.03.02_0_42668	8	1	31111331	B.01.01_0_47067	2	4	31112146	B.11.01_0_38871	14	2
30000795	F.03.04_1_40827	46	1	31112051	A.02.02_0_42523	22	1		C.02.04_0_39172	22	2
30040035	C.03.02_0_39268	14	1	31112082	A.01.01_0_45556	13	2		C.02.04_1_39212	22	2
30040095	B.05.04_0_50716	16	8		A.01.01_1_48842	13	2		D.07.02_0_39660	10	4
31111090	F.04.01_0_46735	26	1		A.01.02_0_48885	13	2		D.07.02_1_39700	11	4
31111091	A.03.01_0_45689	35	4		A.01.02_1_45599	13	2		D.15.04_0_40488	28	4
	A.03.02_0_45727	35	4		A.01.03_0_48930	13	2	31112147	B.11.01_0_38871	17	2
	B.02.01_0_47127	14	2		A.01.03_1_45644	13	2		D.15.04_0_40488	26	2
	B.02.01_1_47161	14	2		A.03.01_0_45689	2	4	31112148	A.02.02_0_42523	13	2
	M.01.01_0_41199	62	1		A.03.02_0_45727	2	4	31112149	B.08.02_0_38771	23	2
31111151	A.01.01_0_45556	7	4		B.01.01_0_47067	22	12		L.01.01_0_40903	9	2
	A.01.01_1_48842	7	4		C.01.02_0_39031	25	8		M.01.01_0_41199	10	2
	A.01.02_0_48885	7	4		E.01.01_0_42630	3	4		M.02.03_0_41409	29	1
	A.01.02_1_45599	7	4		L.01.01_0_40903	14	2		M.02.04_0_41480	29	1
	A.01.03_0_48930	7	4		M.01.01_0_41199	15	2	31112150	A.01.01_0_45556	3	3
	A.01.03_1_45644	7	4	31112090	A.01.01_0_45556	23	2		A.01.01_1_48842	3	3
	A.03.01_0_45689	27	2		A.01.01_1_48842	23	2		A.02.02_0_42523	6	1
	A.03.02_0_45727	27	2		A.01.02_0_48885	23	2		B.01.01_0_47067	5	2
	A.05.02_0_45864	29	1		A.01.02_1_45599	23	2		B.02.01_0_47127	8	2
	B.01.01_0_47067	18	1		A.01.03_0_48930	23	2		B.02.01_1_47161	8	2
	B.04.07_0_40076	24	8		A.01.03_1_45644	23	2		B.04.07_0_40076	35	4

SPARE PARTS INSTANCE INDEX

Code	Parts Table	Pos.	Q.ty	Code	Parts Table	Pos.	Q.ty	Code	Parts Table	Pos.	Q.ty
31112150	D.02.02_0_39318	3	6	31112174	A.01.03_0_48930	15	1	31112219	F.03.04_1_40827	3	3
	D.13.01_0_40355	7	1		A.01.03_1_45644	15	1		L.01.01_0_40903	2	1
	F.01.03_0_51164	25	4	31112178	B.04.07_0_40076	37	2		M.01.01_0_41199	2	1
	F.03.04_0_40779	26	2	31112210	A.01.01_0_45556	31	1	31112264	B.03.03_0_50588	17	8
	F.03.04_1_40827	26	2		A.01.01_1_48842	31	1		B.03.04_0_50621	17	8
	F.04.01_0_46735	2	2		A.01.02_0_48885	31	1	31112272	T.02.01_0_41647	7	4
	L.01.01_0_40903	25	2		A.01.02_1_45599	31	1		T.02.02_0_41675	15	4
	L.02.02_0_40987	24	8		A.01.03_0_48930	31	1	31112328	B.01.01_0_47067	25	2
	L.02.05_0_41145	25	8		A.01.03_1_45644	31	1	31112801	B.05.03_0_50689	19	4
	M.01.01_0_41199	35	2		B.04.07_0_40076	36	1	31122804	B.04.07_0_40076	10	4
	M.02.03_0_41409	23	4		E.02.01_0_46767	5	1	31132440	B.11.01_0_38871	24	4
	M.02.03_0_41409	34	2		F.01.03_0_51164	18	4	31132562	A.02.02_0_42523	2	2
	M.02.04_0_41480	23	4		F.02.01_0_51232	9	2		C.02.04_0_39172	29	4
	M.02.04_0_41480	34	2		F.03.04_0_40779	2	1		C.02.04_1_39212	29	4
	T.02.01_0_41647	13	2		F.03.04_1_40827	2	1	31132566	D.13.01_0_40355	6	1
	T.02.02_0_41675	23	2	31112211	B.04.07_0_40076	8	3	31152057	L.02.02_0_40987	3	2
31112151	A.03.01_0_45689	16	1		C.01.02_0_39031	6	2		L.02.05_0_41145	3	2
	A.03.02_0_45727	16	1		F.03.04_0_40779	6	2		M.02.03_0_41409	3	2
	B.01.01_0_47067	8	1		F.03.04_1_40827	6	2		M.02.04_0_41480	3	2
	C.03.02_0_39268	3	6		L.01.01_0_40903	3	5	31152060	A.02.02_0_42523	17	1
	D.15.04_0_40488	21	1		M.01.01_0_41199	3	4	31152066	B.11.01_0_38871	12	4
31112152	D.07.02_0_39660	11	3	31112212	A.03.01_0_45689	11	2	31152068	A.02.02_0_42523	18	1
	D.07.02_1_39700	12	3		A.03.02_0_45727	11	2	31152083	F.01.03_0_51164	2	4
31112153	A.01.01_0_45556	17	1		C.01.02_0_39031	7	7		F.02.01_0_51232	2	4
	A.01.01_1_48842	17	1	31112213	C.01.02_0_39031	8	1	31152085	D.11.01_0_40184	2	2
	A.01.02_0_48885	17	1	31112217	M.01.01_0_41199	5	1	31152088	B.02.01_0_47127	11	2
	A.01.02_1_45599	17	1	31112219	A.01.01_0_45556	10	5		B.02.01_1_47161	11	2
	A.01.03_0_48930	17	1		A.01.01_1_48842	10	5	31152097	M.01.01_0_41199	47	2
	A.01.03_1_45644	17	1		A.01.02_0_48885	10	5	31152103	A.03.01_0_45689	14	1
31112161	D.11.01_0_40184	3	2		A.01.02_1_45599	10	5		A.03.02_0_45727	14	1
31112174	A.01.01_0_45556	15	1		A.01.03_0_48930	10	5		T.03.03_0_42459	4	2
	A.01.01_1_48842	15	1		A.01.03_1_45644	10	5	31200501	A.04.01_0_45765	3	1
	A.01.02_0_48885	15	1		B.04.07_0_40076	7	3		A.04.02_0_45780	3	1
	A.01.02_1_45599	15	1		F.03.04_0_40779	3	3		A.04.03_0_45796	3	1

SPARE PARTS INSTANCE INDEX

Code	Parts Table	Pos.	Q.ty	Code	Parts Table	Pos.	Q.ty	Code	Parts Table	Pos.	Q.ty
31200501	A.04.04_0_45812	3	1	31211080	D.12.01_1_40279	61	6	31411064	F.03.04_0_40779	40	1
31211050	A.02.02_0_42523	25	1		L.02.02_0_40987	21	12		F.03.04_1_40827	40	1
	E.03.02_0_42668	7	3		L.02.05_0_41145	22	6	31411066	A.03.01_0_45689	37	6
31211060	A.01.01_0_45556	25	2		M.02.03_0_41409	21	3		A.03.02_0_45727	37	6
	A.01.01_1_48842	25	2		M.02.04_0_41480	21	3		B.02.01_1_47161	25	16
	A.01.02_0_48885	25	2	31211100	L.02.02_0_40987	16	4		B.04.07_0_40076	32	4
	A.01.02_1_45599	25	2		L.02.05_0_41145	17	4	31411084	B.01.01_0_47067	6	3
	A.01.03_0_48930	25	2		M.02.03_0_41409	15	2		B.02.01_0_47127	4	6
	A.01.03_1_45644	25	2		M.02.04_0_41480	15	2		B.02.01_1_47161	4	6
	A.03.01_0_45689	36	2		T.02.02_0_41675	10	2		B.04.07_0_40076	25	4
	A.03.02_0_45727	36	2	31211200	T.02.02_0_41675	8.2	1		B.08.02_0_38771	17	4
	B.02.01_0_47127	16	2	31215100	A.01.01_0_45556	37	1		B.08.02_0_38771	24	2
	B.02.01_1_47161	16	2		A.01.02_0_48885	39	1		B.11.01_0_38871	7	4
	B.04.07_0_40076	21	4		A.01.03_0_48930	39	1		D.03.02_0_39758	30	1
	F.02.01_0_51232	8	4	31221161	W.01.04_0_45316	1.5	5		D.03.02_1_39804	27	1
31211080	A.01.01_0_45556	9	2	31231080	A.02.02_0_42523	20	3		F.03.04_0_40779	28	2
	A.01.01_1_48842	9	2		B.01.01_0_47067	15	1		F.03.04_1_40827	28	2
	A.01.02_0_48885	9	2	31231120	D.14.01_0_40378	11	4	31411090	B.01.01_0_47067	10	1
	A.01.02_1_45599	9	2	31241080	B.01.01_0_47067	11	1		B.04.07_0_40076	14	4
	A.01.03_0_48930	9	2	31241121	M.01.01_0_41199	50	2	31411104	M.01.01_0_41199	22	3
	A.01.03_1_45644	9	2	31312089	D.12.01_0_40202	59	4	31411105	D.03.02_0_39758	26	1
	A.03.01_0_45689	18	1		D.12.01_1_40279	60	4		D.03.02_1_39804	23	2
	A.03.02_0_45727	18	1	31313300	C.03.02_0_39268	7	10		D.15.04_0_40488	20	2
	A.04.01_0_45765	4	3	31313320	C.03.02_0_39268	8	6	31411130	D.14.01_0_40378	9	2
	A.04.02_0_45780	4	3	31411053	A.02.02_0_42523	23	1		D.15.04_0_40488	13	2
	A.04.03_0_45796	4	3	31411064	A.01.01_0_45556	14	2	31411150	B.01.01_0_47067	27	2
	A.04.04_0_45812	4	3		A.01.01_1_48842	14	2		D.15.04_0_40488	23	2
	A.05.02_0_45864	10	6		A.01.02_0_48885	14	2	31411170	T.02.01_0_41647	17	2
	B.02.01_0_47127	10	6		A.01.02_1_45599	14	2	31421083	A.01.01_0_45556	18	1
	B.02.01_1_47161	10	6		A.01.03_0_48930	14	2		A.01.01_1_48842	18	1
	B.04.07_0_40076	15	8		A.01.03_1_45644	14	2		A.01.02_0_48885	18	1
	B.11.01_0_38871	40	2		A.03.01_0_45689	4	4		A.01.02_1_45599	18	1
	D.02.02_0_39318	11	1		A.03.02_0_45727	4	4		A.01.03_0_48930	18	1
	D.12.01_0_40202	60	6		E.01.01_0_42630	4	4		A.01.03_1_45644	18	1

SPARE PARTS INSTANCE INDEX

Code	Parts Table	Pos.	Q.ty	Code	Parts Table	Pos.	Q.ty	Code	Parts Table	Pos.	Q.ty
31421083	D.02.02_0_39318	4	6	35211060	B.02.01_1_47161	19	1	51172005	D.10.01_0_39887	3	1
31421251	A.01.01_0_45556	20	1	35211070	M.01.01_0_41199	27	2	51173371	M.01.01_0_41199	49	1
	A.01.01_1_48842	20	1	37111254	D.09.02_0_39867	3	1	51173650	C.03.02_0_39268	2	1
	A.01.02_0_48885	20	1	37111255	D.05.01_0_42870	9	1	51173805	C.01.02_0_39031	16	1
	A.01.02_1_45599	20	1		D.05.01_1_42883	9	1	51173806	C.01.02_0_39031	15	1
	A.01.03_0_48930	20	1	37111354	D.02.02_0_39318	16	1	51174047	M.01.01_0_41199	1	1
	A.01.03_1_45644	20	1	37112302	D.02.02_0_39318	8	1	51174315	L.01.01_0_40903	1	1
31510053	B.08.02_0_38771	6	6	37112501	D.04.01_0_42820	13	1	51174394	D.07.02_0_39660	8	1
34110029	T.02.01_0_41647	9.2	2		D.04.01_1_42845	13	1	51174524V	B.11.01_0_38871	26	1
34110030	M.01.01_0_41199	59	1	37221320	D.06.01_0_42896	25	2	51176033	C.03.02_0_39268	10	1
34130010	T.02.01_0_41647	18	2		D.06.01_1_42932	26	2	51176034	C.03.02_0_39268	11	1
34211054	D.13.01_0_40355	4	1	37931413	D.12.01_1_40279	20	1	51176123	C.03.02_0_39268	1	1
34211064	T.03.03_0_42459	17	1	38104412	D.02.02_0_39318	25	1	51176125	C.01.02_0_39031	2	1
34213018	B.11.01_0_38871	47	1	38110992	D.03.02_0_39758	14	1	51176126	C.01.02_0_39031	1	1
34213054	D.11.01_0_40184	8	1		D.03.02_1_39804	13	1	51176714	B.01.01_0_47067	1	1
34321066	D.15.04_0_40488	7	2	38111078	D.13.01_0_40355	17	2	51177257	W.01.03_0_44163	15	1
35111047	D.12.01_0_40202	4	1	38112200	D.13.01_0_40355	3	1		W.01.04_0_45316	14	1
	D.12.01_1_40279	4	1		F.01.03_0_51164	6	2	51179545	D.07.02_1_39700	9	1
35111052	D.05.01_0_42870	10	1	38113142	F.01.03_0_51164	28	2	51270203	D.11.01_0_40184	15	1
	D.05.01_1_42883	10	1	38114070	D.08.01_0_42969	8	1	51270771	D.07.02_0_39660	31	1
35111062	D.02.02_0_39318	7	2	38116317	D.12.01_0_40202	53	1		D.07.02_1_39700	32	1
	D.09.02_0_39867	2	2		D.12.01_1_40279	54	1	51273893	D.07.02_0_39660	30	1
35111080	D.02.02_0_39318	15	4	38118720	D.12.01_0_40202	54	1	51274388	B.11.01_0_38871	27	1
	D.06.01_0_42896	26	1		D.12.01_1_40279	55	1	51274498	B.11.01_0_38871	28	1
	D.06.01_1_42932	27	1	39118528	W.01.04_0_45316	5	1	51275570	D.13.01_0_40355	13	1
35121014	D.08.01_0_42969	1	2	41U50000	A.01.01_0_45556	1	1	51278573	D.11.01_0_40184	10	1
35121030	D.02.02_0_39318	6	2		A.01.01_1_48842	1	1	51278623	D.07.02_1_39700	31	1
35121035	D.06.01_0_42896	16	1	41U60000	A.01.02_0_48885	1	1	51371035	D.01.02_0_40152	21	1
	D.06.01_1_42932	17	1		A.01.02_1_45599	1	1		D.09.02_0_39867	11	1
35121040	D.04.01_0_42820	11	1	41U70000	A.01.03_0_48930	1	1	52071702	L.01.01_0_40903	13	1
	D.04.01_1_42845	11	1		A.01.03_1_45644	1	1		M.01.01_0_41199	14	1
	D.12.01_0_40202	8	1	50970418	D.15.04_0_40488	33	1	52074435	D.08.01_0_42969	15	2
	D.12.01_1_40279	8	1	50973415	M.01.01_0_41199	40	2	52173669	C.02.04_0_39172	10	1
35211060	B.02.01_0_47127	19	1	51170020	C.03.02_0_39268	6	2		C.02.04_1_39212	10	1

SPARE PARTS INSTANCE INDEX

Code	Parts Table	Pos.	Q.ty	Code	Parts Table	Pos.	Q.ty	Code	Parts Table	Pos.	Q.ty
52173670	C.02.04_0_39172	10	1	52470061	D.01.02_0_40152	17	1	52473837	D.06.01_1_42932	13	1
	C.02.04_1_39212	10	1		D.09.02_0_39867	7	1	52473838	D.04.01_0_42820	5	1
52173671	C.02.04_0_39172	10	1	52470062	D.01.02_0_40152	16	1		D.04.01_1_42845	5	1
	C.02.04_1_39212	10	1		D.09.02_0_39867	6	1	52473839	D.04.01_0_42820	9	1
52173672	C.02.04_0_39172	10	1	52470067	D.01.02_0_40152	20	2		D.04.01_1_42845	9	1
	C.02.04_1_39212	10	1		D.09.02_0_39867	8	2	52474251	D.06.01_0_42896	14	1
52173673	C.02.04_0_39172	10	1	52470087	D.10.01_0_39887	11	3		D.06.01_1_42932	15	1
	C.02.04_1_39212	10	1	52470117	D.06.01_0_42896	18	1	52474252	D.06.01_0_42896	24	1
52272112	D.07.02_0_39660	27	1		D.06.01_1_42932	19	1	52474253	D.06.01_0_42896	21	1
	D.07.02_1_39700	28	1	52470118	D.06.01_0_42896	17	1	52474254	D.04.01_0_42820	17	1
52273364	D.07.02_0_39660	28	1		D.06.01_1_42932	18	1	52475073	D.04.01_0_42820	20	1
	D.07.02_1_39700	29	1	52470298	D.12.01_0_40202	7	1	52475560	D.12.01_0_40202	27	1
52274299	D.07.02_0_39660	25	1		D.12.01_1_40279	7	1	52475562	D.12.01_1_40279	32	1
	D.07.02_1_39700	26	1	52470762	D.04.01_0_42820	18	1	52475565	D.12.01_0_40202	42	1
52370072	D.10.01_0_39887	6	1	52473655	D.02.02_0_39318	35	1		D.12.01_1_40279	43	1
52370075	D.10.01_0_39887	5	1	52473656	D.04.01_0_42820	24	1	52475991	D.12.01_0_40202	23	1
52370152	D.13.01_0_40355	2	1		D.04.01_1_42845	24	1		D.12.01_1_40279	24	1
52372292	D.12.01_0_40202	37	1	52473660	D.02.02_0_39318	12	1	52475992	D.12.01_0_40202	45	1
	D.12.01_1_40279	38	1	52473827	D.05.01_0_42870	8	1		D.12.01_1_40279	46	1
52373177	D.15.04_0_40488	10	2		D.05.01_1_42883	8	1	52475994	D.12.01_0_40202	43/1	1
52373668	C.02.04_0_39172	5	2	52473828	D.05.01_0_42870	3	1		D.12.01_1_40279	44/1	1
52374189	D.07.02_0_39660	2	2	52473829	D.05.01_0_42870	5	1	52475996	D.12.01_0_40202	43/2	1
	D.07.02_1_39700	2	1		D.05.01_1_42883	5	1		D.12.01_1_40279	44/2	1
52374386	D.07.02_0_39660	3	1	52473830	D.05.01_0_42870	6	1	52476062	D.12.01_0_40202	16	1
	D.07.02_1_39700	3	1		D.05.01_1_42883	6	1		D.12.01_1_40279	17	1
52374641	D.11.01_0_40184	1	1	52473831	D.05.01_0_42870	7	1	52476065	D.12.01_0_40202	21/1	1
52375215	D.15.04_0_40488	14	1		D.05.01_1_42883	7	1		D.12.01_1_40279	22/1	1
52375896	D.07.02_0_39660	26	2	52473833	D.06.01_0_42896	3	1	52476066	D.12.01_0_40202	21/2	1
	D.07.02_1_39700	27	1	52473834	D.06.01_0_42896	6	1		D.12.01_1_40279	22/2	1
52375897	D.07.02_0_39660	29	1	52473835	D.06.01_0_42896	8	1	52476067	D.12.01_0_40202	19	1
52378628	D.07.02_1_39700	36	1		D.06.01_1_42932	9	1	52476068	D.12.01_0_40202	15	1
52378629	D.07.02_1_39700	30	1	52473836	D.06.01_0_42896	11	1		D.12.01_1_40279	16	1
52378636	D.07.02_1_39700	4	1		D.06.01_1_42932	12	1	52476868	D.12.01_0_40202	3	1
52379209	C.02.04_1_39212	5	2	52473837	D.06.01_0_42896	12	1		D.12.01_1_40279	3	1

SPARE PARTS INSTANCE INDEX

Code	Parts Table	Pos.	Q.ty	Code	Parts Table	Pos.	Q.ty	Code	Parts Table	Pos.	Q.ty
52478565	D.12.01_1_40279	28	1	55176744	A.01.03_1_45644	26	1	56076928	B.02.01_0_47127	1.3	1
52478568	D.12.01_1_40279	19	1	55177639	A.03.01_0_45689	23	1		B.02.01_1_47161	1.3	1
52478609	D.06.01_1_42932	7	1		A.03.02_0_45727	23	1	56076929	B.02.01_0_47127	1.4	1
52478611	D.06.01_1_42932	3	1	55271644	B.08.02_0_38771	5	1		B.02.01_1_47161	1.4	1
52478612	D.05.01_1_42883	3	1	55274441	B.08.02_0_38771	4	1	56076930	B.02.01_0_47127	1.5	1
52478615	D.06.01_1_42932	22	1	55276745	A.05.02_0_45864	1	1		B.02.01_1_47161	1.5	1
52478617	D.06.01_1_42932	25	1	56071768	A.02.02_0_42523	12	4	56076931	B.02.01_0_47127	1.2	1
52478618	D.04.01_1_42845	17	1	56073059	T.02.01_0_41647	12.1	1	56076933	B.02.01_1_47161	1.2	1
52478619	D.04.01_1_42845	18	1		T.02.02_0_41675	21.2	1	56077235	D.15.04_0_40488	36	1
52478620	D.04.01_1_42845	20	1	56073413	M.01.01_0_41199	44	2	56077608	A.05.02_0_45864	6	2
52573648	D.02.02_0_39318	21	1	56073414	M.01.01_0_41199	41	2	56077760	M.02.03_0_41409	43	1
53273025	D.02.02_0_39318	26	1	56073416	M.01.01_0_41199	45	1		M.02.04_0_41480	43	1
53273886	D.12.01_0_40202	32	1	56074302	D.03.02_0_39758	28	1	56077774	T.02.01_0_41647	2	2
	D.12.01_1_40279	33	1		D.03.02_1_39804	25	1	56078831	B.04.07_0_40076	33	1
53273891	D.12.01_0_40202	55	1	56074313	D.12.01_0_40202	64	1	56079442	B.02.01_1_47161	1.1	1
	D.12.01_1_40279	56	1		D.12.01_1_40279	65	1	56170017	D.07.02_0_39660	15	1
55072935	B.05.03_0_50689	1	4	56075036	T.02.02_0_41675	17	2		D.07.02_1_39700	16	1
55170047	D.14.01_0_40378	7	2	56075143	M.01.01_0_41199	58	1	56170029	D.03.02_0_39758	15	1
55170053	D.07.02_0_39660	5	3	56075145	M.01.01_0_41199	26	1		D.03.02_1_39804	14	1
	D.07.02_1_39700	6	3	56075161	M.02.03_0_41409	33	1	56170043	D.14.01_0_40378	8	2
55174162	B.11.01_0_38871	33	1		M.02.04_0_41480	33	1	56170074	D.10.01_0_39887	9	1
55174163	B.11.01_0_38871	32	2	56075185	M.02.03_0_41409	46	1	56170213	D.01.02_0_40152	8	1
55174429	C.02.04_0_39172	27	2		M.02.04_0_41480	46	1	56170214	D.01.02_0_40152	6	1
	C.02.04_1_39212	27	2	56075186	M.02.03_0_41409	47	1	56170276	A.05.02_0_45864	16	2
55174632	A.03.01_0_45689	21	1		M.02.04_0_41480	47	1	56170283	L.01.01_0_40903	27	2
	A.03.02_0_45727	21	1	56075197	M.02.03_0_41409	42	1		M.01.01_0_41199	37	2
55175174	B.04.07_0_40076	13	6		M.02.04_0_41480	42	1	56170285	L.01.01_0_40903	29	2
	B.05.03_0_50689	22	8	56075230	D.03.02_0_39758	36	1		M.01.01_0_41199	39	2
	B.05.04_0_50716	18	8		D.03.02_1_39804	33	1	56170286	L.01.01_0_40903	28	2
55176744	A.01.01_0_45556	26	1	56075252	M.02.03_0_41409	38	1		M.01.01_0_41199	38	2
	A.01.01_1_48842	26	1		M.02.04_0_41480	38	1	56170350	F.01.03_0_51164	13	1
	A.01.02_0_48885	26	1	56076055	D.13.01_0_40355	20	1	56170364	C.02.04_0_39172	21	2
	A.01.02_1_45599	26	1	56076074	D.12.01_0_40202	18	1		C.02.04_1_39212	21	2
	A.01.03_0_48930	26	1	56076927	B.02.01_0_47127	1.1	1	56170367	D.15.04_0_40488	3	2



SPARE PARTS INSTANCE INDEX

Code	Parts Table	Pos.	Q.ty	Code	Parts Table	Pos.	Q.ty	Code	Parts Table	Pos.	Q.ty
56170392	T.02.01_0_41647	3	2	56174201	L.02.02_0_40987	23	1	56174635	A.05.02_0_45864	5	1
56170447	D.13.01_0_40355	11	1		L.02.05_0_41145	24	1	56174636	A.04.01_0_45765	2	1
56170704	T.03.01_0_41710	6	1		M.02.03_0_41409	22	1		A.04.02_0_45780	2	1
	T.03.02_0_41719	4	1		M.02.04_0_41480	22	1		A.04.03_0_45796	2	1
56170705	T.03.01_0_41710	7	1	56174227	L.02.02_0_40987	22	1		A.04.04_0_45812	2	1
	T.03.02_0_41719	5	1		L.02.05_0_41145	23	1	56174656	B.02.01_0_47127	12	1
56170760	D.06.01_0_42896	23	1	56174400	D.03.02_0_39758	41	1		B.02.01_1_47161	12	1
	D.06.01_1_42932	24	1		D.03.02_1_39804	38	1	56174657	B.01.01_0_47067	4	1
56170795	D.15.04_0_40488	8	1	56174401	D.03.02_0_39758	42	1	56174658	B.01.01_0_47067	7	1
56170796	D.15.04_0_40488	9	1		D.03.02_1_39804	39	1	56174659	B.01.01_0_47067	9	1
56170964	L.02.02_0_40987	17	4	56174431	D.13.01_0_40355	10	1	56174661	A.02.02_0_42523	16	1
	L.02.05_0_41145	18	4	56174446	C.02.04_0_39172	28	4	56174665	F.04.01_0_46735	1	1
	M.02.03_0_41409	16	2		C.02.04_1_39212	28	4	56174666	B.04.07_0_40076	23	1
	M.02.04_0_41480	16	2	56174461	B.11.01_0_38871	42	1	56174667	B.04.07_0_40076	22	1
56171223	B.12.04_0_51054	13	1	56174462	B.11.01_0_38871	37	1	56174692	D.06.01_0_42896	23	1
56171572	D.12.01_0_40202	1	1	56174463	B.11.01_0_38871	45	1		D.06.01_1_42932	24	1
	D.12.01_1_40279	1	1	56174464	B.11.01_0_38871	10	1	56174693	D.06.01_0_42896	23	1
56171877	A.02.02_0_42523	3	1	56174480	F.03.04_0_40779	10	1		D.06.01_1_42932	24	1
56171883	A.02.02_0_42523	4	1		F.03.04_1_40827	10	1	56174694	D.06.01_0_42896	23	1
56171936	D.15.04_0_40488	18	1	56174481	F.03.04_0_40779	9	1		D.06.01_1_42932	24	1
56171954	B.04.07_0_40076	16	2		F.03.04_1_40827	9	1	56174695	D.06.01_0_42896	23	1
	B.05.03_0_50689	23	8	56174485	F.03.04_0_40779	30	1		D.06.01_1_42932	24	1
	B.05.04_0_50716	19	8		F.03.04_1_40827	30	1	56174725	F.01.03_0_51164	15	2
56171996	B.04.07_0_40076	12	4	56174486	B.11.01_0_38871	13	1	56174773	B.11.01_0_38871	11	1
56172172	B.12.03_0_46827	7/2	1	56174489	B.11.01_0_38871	16	1	56174835	B.02.01_0_47127	18	1
56172538	C.01.02_0_39031	24	1	56174492	B.11.01_0_38871	2	2		B.02.01_1_47161	18	1
56172547	F.02.01_0_51232	13	1	56174493	C.02.04_0_39172	9	1	56174873	B.01.01_0_47067	24	1
56172749	F.04.01_0_46735	4	1	56174494	F.03.04_0_40779	44	1	56174919	C.01.02_0_39031	23	1
56173638	L.01.01_0_40903	8	1		F.03.04_1_40827	43	1	56174987	F.02.01_0_51232	4	1
	M.01.01_0_41199	9	1	56174499	B.11.01_0_38871	20	1	56174988	F.02.01_0_51232	5	1
56173684	D.03.02_0_39758	23	1	56174635	A.04.01_0_45765	5	1	56175294	F.02.01_0_51232	17	1
	D.03.02_1_39804	20	1		A.04.02_0_45780	5	1	56175367	D.06.01_0_42896	23	1
56174108	D.12.01_0_40202	5	1		A.04.03_0_45796	5	1		D.06.01_1_42932	24	1
	D.12.01_1_40279	5	1		A.04.04_0_45812	5	1	56175848	T.02.02_0_41675	5	2

SPARE PARTS INSTANCE INDEX

Code	Parts Table	Pos.	Q.ty
56176127	D.11.01_0_40184	7	1
56176691	A.03.01_0_45689	15	1
	A.03.02_0_45727	15	1
56176696	A.05.02_0_45864	8	2
56176716	A.05.02_0_45864	7	1
56176814	A.05.02_0_45864	9	3
56176905	B.03.03_0_50588	14	1
	B.03.04_0_50621	14	1
56176906	B.03.03_0_50588	13	1
	B.03.04_0_50621	13	1
56176907	B.05.03_0_50689	13	1
	B.05.04_0_50716	11	1
56176908	B.05.03_0_50689	12	1
	B.05.04_0_50716	10	1
56177045	B.03.03_0_50588	32	8
	B.03.04_0_50621	18	8
	B.05.03_0_50689	26	8
	B.05.04_0_50716	21	8
56177068	C.01.02_0_39031	20	1
56177183	A.01.01_0_45556	34	1
	A.01.01_1_48842	34	1
	A.01.02_0_48885	34	1
	A.01.02_1_45599	34	1
	A.01.03_0_48930	34	1
	A.01.03_1_45644	34	1
56177252	B.05.03_0_50689	2	2
56177256	B.03.03_0_50588	3	2
	B.03.04_0_50621	3	2
56177264	B.05.03_0_50689	15	1
	B.05.04_0_50716	13	1
56177265	B.05.03_0_50689	16	1
	B.05.04_0_50716	14	1
56177326	B.03.03_0_50588	10	2
	B.03.04_0_50621	10	2

Code	Parts Table	Pos.	Q.ty
56177416	W.01.04_0_45316	1.1	1
56177417	W.01.04_0_45316	1.2	1
56177443	B.05.03_0_50689	5	1
	B.05.04_0_50716	3	1
56177444	B.05.03_0_50689	6	1
	B.05.04_0_50716	4	1
56177475	B.05.03_0_50689	21	2
56177643	B.01.01_0_47067	17	1
56177655	A.02.02_0_42523	21	1
56177656	A.02.02_0_42523	19	3
	B.01.01_0_47067	14	1
56177671	T.02.02_0_41675	20	2
56177979	A.01.01_0_45556	8	1
	A.01.01_1_48842	8	1
	A.01.02_0_48885	8	1
	A.01.02_1_45599	8	1
	A.01.03_0_48930	8	1
	A.01.03_1_45644	8	1
56178560	B.04.07_0_40076	38	2
56178591	B.12.04_0_51054	15	1
56178649	A.01.02_0_48885	35	1
	A.01.02_1_45599	35	1
	A.01.03_0_48930	35	1
	A.01.03_1_45644	35	1
56178695	F.04.01_0_46735	29	1
56178805	A.03.01_0_45689	7	1
	A.03.02_0_45727	7	1
56178806	A.03.01_0_45689	12	2
	A.03.02_0_45727	12	2
56179443	B.02.01_1_47161	22	1
56179444	B.02.01_1_47161	23	1
56179445	B.03.03_0_50588	12	1
	B.03.04_0_50621	12	1
56179447	B.02.01_1_47161	21	2

Code	Parts Table	Pos.	Q.ty
56179549	B.02.01_0_47127	7	1
	B.02.01_1_47161	7	1
56274487	B.11.01_0_38871	35	2
56275953	T.02.02_0_41675	8.1	1
56276371	C.02.04_0_39172	25.1	1
	C.02.04_1_39212	24.2	1
56276372	C.02.04_0_39172	25	1
	C.02.04_1_39212	24.1	1
56278614	D.06.01_1_42932	6	1
56370018	D.07.02_0_39660	9	6
	D.07.02_1_39700	10	6
56370037	D.02.02_0_39318	33	1
56370038	D.14.01_0_40378	4	2
56370076	D.10.01_0_39887	10	6
56370079	D.10.01_0_39887	7	1
56370081	C.01.02_0_39031	4	2
	D.10.01_0_39887	15	1
	L.02.05_0_41145	48	1
	M.02.04_0_41480	62	1
56370089	D.01.02_0_40152	15	1
	D.06.01_0_42896	27	1
	D.06.01_1_42932	28	1
	D.09.02_0_39867	14	1
56370127	D.01.02_0_40152	15	1
	D.06.01_0_42896	27	1
	D.06.01_1_42932	28	1
	D.09.02_0_39867	14	1
56370128	D.01.02_0_40152	15	1
	D.06.01_0_42896	27	1
	D.06.01_1_42932	28	1
	D.09.02_0_39867	14	1
56370154	D.07.02_0_39660	24	1
56370165	D.07.02_0_39660	22	1
	D.07.02_1_39700	23	1

SPARE PARTS INSTANCE INDEX

Code	Parts Table	Pos.	Q.ty	Code	Parts Table	Pos.	Q.ty	Code	Parts Table	Pos.	Q.ty
56370172	D.07.02_0_39660	18	3	56371065	D.07.02_0_39660	20	1	56378622	D.07.02_1_39700	24	1
	D.07.02_1_39700	19	3		D.07.02_1_39700	21	1	56378630	D.07.02_1_39700	25	1
56370177	D.07.02_0_39660	21	1	56371162	D.02.02_0_39318	18	1	56470002	D.02.02_0_39318	19	1
	D.07.02_1_39700	22	1	56371721	D.15.04_0_40488	15	1	56470110	D.04.01_0_42820	3	1
56370178	C.02.04_0_39172	14	2	56372282	D.12.01_0_40202	40	1		D.04.01_1_42845	3	1
	C.02.04_1_39212	14	2		D.12.01_1_40279	41	1	56470111	D.04.01_0_42820	14	1
	D.12.01_0_40202	6	1	56372536	D.01.02_0_40152	3	1		D.04.01_1_42845	14	1
	D.12.01_1_40279	6	1	56373194	D.03.02_0_39758	33	1	56470137	D.06.01_0_42896	10	1
	D.13.01_0_40355	14	1		D.03.02_1_39804	30	2		D.06.01_1_42932	11	1
56370186	D.07.02_0_39660	13	5	56373213	D.07.02_0_39660	23	1	56470138	D.06.01_0_42896	9	3
	D.07.02_1_39700	14	5	56373426	M.01.01_0_41199	42	1		D.06.01_1_42932	10	3
56370187	D.11.01_0_40184	5	1	56373427	M.01.01_0_41199	42	1	56470139	D.04.01_0_42820	10	1
56370209	D.01.02_0_40152	11	1	56373428	M.01.01_0_41199	42	1		D.04.01_1_42845	10	1
56370210	D.01.02_0_40152	11	1	56373436	M.01.01_0_41199	53	1	56470215	D.01.02_0_40152	4	1
56370211	D.01.02_0_40152	11	1	56373800	C.01.02_0_39031	18	2	56470231	D.14.01_0_40378	5	2
56370212	D.01.02_0_40152	11	1		C.03.02_0_39268	12	2	56470299	D.13.01_0_40355	1	1
56370267	D.02.02_0_39318	28	1	56373840	D.06.01_0_42896	1	1	56470365	D.15.04_0_40488	19	2
56370282	L.01.01_0_40903	22	4		D.06.01_1_42932	1	1	56470797	D.15.04_0_40488	11	2
	M.01.01_0_41199	32	4	56374430	D.13.01_0_40355	5	1	56470813	D.01.02_0_40152	23	2
56370287	L.01.01_0_40903	24	2	56374460	B.11.01_0_38871	46	1	56470814	D.09.02_0_39867	15	1
	M.01.01_0_41199	34	2	56374556	C.02.04_0_39172	13	2	56470815	D.09.02_0_39867	16	1
56370288	L.01.01_0_40903	17	2		C.02.04_1_39212	13	2	56470987	D.12.01_0_40202	29	1
	M.01.01_0_41199	18	1	56374557	C.02.04_0_39172	15	2		D.12.01_1_40279	30	1
56370539	W.01.03_0_44163	14	4		C.02.04_1_39212	15	2	56471036	D.01.02_0_40152	18	1
	W.01.04_0_45316	13	4	56374574	M.01.01_0_41199	51	1		D.09.02_0_39867	10	1
56370582	D.11.01_0_40184	14	1	56375008	T.03.02_0_41719	2	4	56473818	D.04.01_0_42820	6	1
56370583	D.11.01_0_40184	13	1	56375146	M.01.01_0_41199	25	1		D.04.01_1_42845	6	1
56370696	T.03.01_0_41710	4	4	56375147	M.01.01_0_41199	21	1	56473890	D.12.01_0_40202	51	1
56370761	D.06.01_0_42896	22	1	56375436	B.11.01_0_38871	36	1		D.12.01_1_40279	52	1
56370830	D.06.01_0_42896	27	1	56375571	D.13.01_0_40355	15	1	56474713	D.12.01_0_40202	51	1
	D.06.01_1_42932	28	1	56375954	T.02.02_0_41675	6	4		D.12.01_1_40279	52	1
	D.09.02_0_39867	14	1	56376256	D.11.01_0_40184	9	1	56474714	D.12.01_1_40279	52	1
56371037	D.01.02_0_40152	19	1	56378566	D.12.01_1_40279	26	2	56475398	D.12.01_0_40202	51	1
	D.09.02_0_39867	9	1	56378616	D.06.01_1_42932	23	1	56475416	D.12.01_0_40202	51	1

SPARE PARTS INSTANCE INDEX

Code	Parts Table	Pos.	Q.ty	Code	Parts Table	Pos.	Q.ty	Code	Parts Table	Pos.	Q.ty
56475417	D.12.01_0_40202	51	1	57275031	B.04.07_0_40076	18	1	57376899	B.02.01_1_47161	17/2	1
56475516	D.12.01_0_40202	49	1	57371900	A.05.02_0_45864	2	1	57376900	B.03.03_0_50588	27	2
	D.12.01_1_40279	50	1	57374490	B.11.01_0_38871	4	2	57377317	A.04.02_0_45780	8	1
56475517	D.12.01_0_40202	51	1	57374491	B.11.01_0_38871	5	1		A.04.04_0_45812	8	1
	D.12.01_1_40279	52	1	57374501	B.11.01_0_38871	30	1	57377704	B.05.03_0_50689	7	1
56475518	D.12.01_1_40279	52	1	57374506	B.04.07_0_40076	28	1		B.05.04_0_50716	5	1
56475568	D.12.01_0_40202	22	1	57374507	B.04.07_0_40076	29	1	57377707	B.05.03_0_50689	8	1
	D.12.01_1_40279	23	1	57374522	B.03.03_0_50588	4	1		B.05.04_0_50716	6	1
56475757	D.12.01_0_40202	51	1		B.03.04_0_50621	4	1	57379438	B.02.01_1_47161	27	1
56475839	D.08.01_0_42969	5	1	57374523	B.03.03_0_50588	5	1	58025869	M.01.01_0_41199	42	1
56475844	D.12.01_0_40202	52	1		B.03.04_0_50621	5	1	58048002	A.02.02_0_42523	26	3
	D.12.01_1_40279	53	1	57374545	B.11.01_0_38871	25	2		B.01.01_0_47067	12	1
56476073	D.12.01_0_40202	25	1	57374553	B.08.02_0_38771	21	1	58070071	D.10.01_0_39887	4	1
56477227	C.02.04_0_39172	26	1	57374594	B.04.07_0_40076	3	1	58070164	D.07.02_0_39660	17	3
	C.02.04_1_39212	26	1	57374595	B.04.07_0_40076	4	1		D.07.02_1_39700	18	3
56478567	D.12.01_1_40279	25	1	57375195	M.02.03_0_41409	39	1	58070168	D.07.02_0_39660	19	3
56570016	C.02.04_0_39172	1.1	2		M.02.04_0_41480	39	1		D.07.02_1_39700	20	3
	C.02.04_1_39212	1.1	2	57376621	B.03.03_0_50588	8	1	58070169	D.07.02_0_39660	7	3
	D.07.02_0_39660	16	1		B.03.04_0_50621	8	1		D.07.02_1_39700	8	3
	D.07.02_1_39700	17	1	57376622	B.03.03_0_50588	9	1	58070198	D.11.01_0_40184	12	1
	L.01.01_0_40903	5	2		B.03.04_0_50621	9	1	58070205	D.11.01_0_40184	17	1
	M.01.01_0_41199	6	2	57376623	B.05.03_0_50689	9	1	58070262	D.02.02_0_39318	27	1
56570125	D.07.02_0_39660	37	2		B.05.04_0_50716	7	1	58070268	D.02.02_0_39318	29	1
	D.07.02_1_39700	39	2	57376624	B.05.03_0_50689	10	1	58070366	D.14.01_0_40378	10	2
56570219	D.06.01_0_42896	4	1		B.05.04_0_50716	8	1	58070390	B.11.01_0_38871	44	1
56570284	L.01.01_0_40903	15	1	57376670	B.02.01_0_47127	17/1	1	58070480	T.02.01_0_41647	9.1	2
	M.01.01_0_41199	16	1		B.02.01_1_47161	17/1	1	58070482	T.02.01_0_41647	10.3	1
56570506	M.01.01_0_41199	20	1	57376675	B.03.03_0_50588	6	1		T.02.02_0_41675	19.3	2
56573661	D.02.02_0_39318	5	1		B.03.04_0_50621	6	1	58070513	L.02.02_0_40987	38	1
56575035	T.02.02_0_41675	1	2	57376676	B.03.03_0_50588	7	1		L.02.05_0_41145	39	1
56577772	T.02.01_0_41647	1	2		B.03.04_0_50621	7	1		M.02.03_0_41409	54	1
56578610	D.06.01_1_42932	4	1	57376726	A.01.01_0_45556	2	1		M.02.04_0_41480	54	1
57174915	A.05.02_0_45864	1.3	1		A.01.01_1_48842	2	1	58070690	A.05.02_0_45864	19	1
57275029	B.04.07_0_40076	17	1	57376899	B.02.01_0_47127	17/2	1	58070741	D.07.02_0_39660	35	5

SPARE PARTS INSTANCE INDEX

Code	Parts Table	Pos.	Q.ty	Code	Parts Table	Pos.	Q.ty	Code	Parts Table	Pos.	Q.ty
58070741	D.07.02_1_39700	37	5	58074092	D.12.01_1_40279	40	1	58075021	B.07.02_0_42592	20	1
	D.13.01_0_40355	18	2	58074220	B.07.02_0_42592	13	1	58075022	B.07.02_0_42592	17	1
58070790	D.03.02_0_39758	20	2	58074221	B.07.02_0_42592	12	1	58075080	L.02.02_0_40987	39	2
	D.03.02_1_39804	17	3	58074222	B.07.02_0_42592	14	1		L.02.05_0_41145	40	2
	D.15.04_0_40488	5	2	58074488	B.11.01_0_38871	38	1	58075082	L.02.02_0_40987	47	1
58071313	E.02.01_0_46767	3	1	58074558	D.03.02_0_39758	10	2		M.02.03_0_41409	62	1
58071322	T.02.01_0_41647	4	2		D.03.02_1_39804	9	1	58075153	B.07.02_0_42592	18	1
58071755	T.02.01_0_41647	10.1	2	58074734	F.03.04_0_40779	32	2	58075159	M.02.03_0_41409	27	1
	T.02.02_0_41675	19.1	2		F.03.04_1_40827	32	2		M.02.04_0_41480	27	1
58071757	T.02.01_0_41647	11	2	58074736	F.04.01_0_46735	27	1	58075160	M.02.03_0_41409	50	1
	T.02.02_0_41675	22	2	58074738	F.03.04_0_40779	15	1		M.02.04_0_41480	50	1
58072074	A.02.02_0_42523	9	1	58074740	F.03.04_0_40779	17	1	58075226	L.02.02_0_40987	41	1
58072075	A.02.02_0_42523	10	1		F.03.04_1_40827	17	1		L.02.05_0_41145	42	2
58072081	E.02.01_0_46767	4	1	58074777	B.07.02_0_42592	10	1		M.02.03_0_41409	56	1
58072107	D.08.01_0_42969	3	1	58074786	B.07.02_0_42592	5	1		M.02.04_0_41480	56	1
58072389	D.12.01_0_40202	38	1	58074787	B.07.02_0_42592	6	1	58075247	L.02.02_0_40987	6	1
	D.12.01_1_40279	39	1	58074791	B.07.02_0_42592	4	2		L.02.05_0_41145	6	1
58072398	D.12.01_0_40202	46	4	58074792	B.07.02_0_42592	1	1		M.02.03_0_41409	6	1
	D.12.01_1_40279	47	4	58074793	B.07.02_0_42592	2	1		M.02.04_0_41480	6	1
58072399	D.12.01_0_40202	41	1	58074831	B.01.01_0_47067	16	1	58075248	F.03.04_0_40779	35	1
	D.12.01_1_40279	42	1	58074836	F.03.04_0_40779	11	1		F.03.04_1_40827	35	1
58072509	B.07.02_0_42592	30	1		F.03.04_1_40827	11	1	58075250	B.07.02_0_42592	19	1
58072510	B.07.02_0_42592	33	1	58074839	B.07.02_0_42592	15	1	58075358	L.02.02_0_40987	34	1
58072511	B.07.02_0_42592	32	1	58074841	B.07.02_0_42592	8	1		L.02.05_0_41145	35	1
58072517	B.07.02_0_42592	31	1	58074846	B.07.02_0_42592	16	1	58075603	L.01.01_0_40903	7	1
58072518	B.07.02_0_42592	22/1	1	58074880	B.07.02_0_42592	11	1		M.01.01_0_41199	8	1
58072574	B.07.02_0_42592	22/2	1	58074891	F.03.04_0_40779	16	1	58075873	A.03.01_0_45689	30	1
58072575	B.07.02_0_42592	23	1		F.03.04_1_40827	16	1		A.03.02_0_45727	30	1
58072737	B.07.02_0_42592	28	1	58074895	A.05.02_0_45864	21	1	58075983	T.02.01_0_41647	12	1
58073156	B.07.02_0_42592	27	2	58074904	E.01.01_0_42630	1	1	58075987	T.02.02_0_41675	21	1
58073411	M.01.01_0_41199	43	2	58074958	L.02.02_0_40987	40	2	58076077	B.07.02_0_42592	21	1
58073461	D.02.02_0_39318	12.1	1		L.02.05_0_41145	41	2	58076333	F.02.01_0_51232	15	1
58073889	D.12.01_1_40279	51	1		M.02.03_0_41409	55	2	58076334	F.02.01_0_51232	16	1
58074092	D.12.01_0_40202	39	1		M.02.04_0_41480	55	2	58076355	T.02.01_0_41647	9	2

SPARE PARTS INSTANCE INDEX

Code	Parts Table	Pos.	Q.ty	Code	Parts Table	Pos.	Q.ty	Code	Parts Table	Pos.	Q.ty
58076750	A.04.03_0_45796	8	1	58078631	A.02.02_0_42523	8	1	58170279	D.04.01_0_42820	8	1
	A.04.04_0_45812	9	1	58078677	A.03.01_0_45689	29	1		D.04.01_1_42845	8	1
58076751	A.04.01_0_45765	8	1		A.03.02_0_45727	29	1	58170291	L.01.01_0_40903	16	2
	A.04.02_0_45780	9	1	58079118	C.02.04_0_39172	1.2	1		M.01.01_0_41199	17	2
58076752	A.05.02_0_45864	11	3		C.02.04_1_39212	1.2	1	58170306	D.02.02_0_39318	20	2
58076753	A.04.01_0_45765	6	1	58079392	E.03.02_0_42668	3	1	58170344	B.08.02_0_38771	19	1
	A.04.03_0_45796	6	1	58079393	E.03.02_0_42668	4	1	58170345	B.08.02_0_38771	20	1
58076984V	B.02.01_0_47127	21	1	58079394	E.01.01_0_42630	6	1	58170376	B.08.02_0_38771	15	2
	B.02.01_1_47161	28	1	58079395	E.01.01_0_42630	5	1	58170436	B.02.01_0_47127	3	1
58076987V	B.02.01_0_47127	22	1	58079433	F.03.04_1_40827	15	1		B.02.01_1_47161	3	1
	B.02.01_1_47161	29	1	58079434	F.03.04_1_40827	48	1	58170443	D.02.02_0_39318	23	1
58077061	E.03.02_0_42668	10	1	58079435	F.03.04_1_40827	47	1	58170449	T.02.01_0_41647	15	1
58077062	E.03.02_0_42668	11	1	58079466	B.07.02_0_42592	7	1		T.02.02_0_41675	25	1
58077132	A.03.01_0_45689	32	1	58079755	E.02.01_0_46767	7	1	58170453	B.08.02_0_38771	7.1	1
	A.03.02_0_45727	32	1	58092972	B.02.01_0_47127	2	1		E.03.02_0_42668	1.1	1
58077202	T.02.01_0_41647	19	2		B.02.01_1_47161	2	1	58170512	L.02.02_0_40987	35	1
58077205	T.02.01_0_41647	10	2	58170021	C.03.02_0_39268	4	1		L.02.05_0_41145	36	1
58077226	C.02.04_0_39172	25.2	1	58170026	D.15.04_0_40488	30	2		M.02.03_0_41409	51	1
	C.02.04_1_39212	25	1	58170034	D.02.02_0_39318	30	6		M.02.04_0_41480	51	1
58077305	E.03.02_0_42668	16	1	58170045	D.14.01_0_40378	1	2	58170571	E.03.02_0_42668	4.2	1
58077325	T.02.02_0_41675	19	2	58170054	D.07.02_0_39660	6	3	58170572	E.03.02_0_42668	4.1	1
58077413	F.03.04_0_40779	29	1		D.07.02_1_39700	7	3	58170693	F.04.01_0_46735	20/2	1
	F.03.04_1_40827	29	1	58170070	D.10.01_0_39887	12	3		L.02.02_0_40987	29	1
58077484	A.01.02_0_48885	37	1	58170077	C.02.04_0_39172	11	2		L.02.05_0_41145	30	1
	A.01.03_0_48930	37	1		C.02.04_1_39212	11	2	58170703	D.14.01_0_40378	2	6
58077579	B.07.02_0_42592	3/3	2	58170130	D.04.01_0_42820	23	1	58170968	B.03.03_0_50588	25	1
58077580	B.07.02_0_42592	3/2	2		D.04.01_1_42845	23	1	58171000	T.02.02_0_41675	11	2
58077581	B.07.02_0_42592	3/1	2		D.12.01_0_40202	10	1	58171019	D.14.01_0_40378	3	2
58077601	B.08.02_0_38771	7/1	1		D.12.01_1_40279	10	1	58171021	T.02.01_0_41647	4.2	1
	E.03.02_0_42668	1/1	1	58170181	W.01.03_0_44163	1.1	1		T.02.02_0_41675	12/1	2
58077602	B.08.02_0_38771	7/2	1	58170195	D.11.01_0_40184	6	2	58171027	A.04.01_0_45765	1.4	1
	E.03.02_0_42668	1/2	1	58170238	A.05.02_0_45864	3	1		A.04.02_0_45780	1.4	1
58077615	B.07.02_0_42592	9	1	58170245	L.01.01_0_40903	21	2		A.04.03_0_45796	1.4	1
58077654	B.07.02_0_42592	24	1		M.01.01_0_41199	31	2		A.04.04_0_45812	1.4	1

SPARE PARTS INSTANCE INDEX

Code	Parts Table	Pos.	Q.ty	Code	Parts Table	Pos.	Q.ty	Code	Parts Table	Pos.	Q.ty
58171028	A.04.01_0_45765	1.3	1	58172012	L.02.02_0_40987	13/1	2	58172304	I.01.01_0_40883	7	1
	A.04.02_0_45780	1.3	1		L.02.05_0_41145	13/1	2		L.02.02_0_40987	11	2
	A.04.03_0_45796	1.3	1		L.02.05_0_41145	14	1		L.02.05_0_41145	11	2
	A.04.04_0_45812	1.3	1		M.02.03_0_41409	13/1	1		M.02.03_0_41409	12	1
58171069	A.04.02_0_45780	6	1		M.02.04_0_41480	13/1	1		M.02.04_0_41480	12	1
	A.04.04_0_45812	6	1		M.02.04_0_41480	14/1	1	58172400	D.02.02_0_39318	24	1
58171139	D.06.01_0_42896	7	2	58172013	I.01.01_0_40883	4	1		D.12.01_0_40202	33	1
	D.06.01_1_42932	8	2		L.02.02_0_40987	13/2	2		D.12.01_1_40279	34	1
58171199	A.01.01_0_45556	1.1	1		L.02.05_0_41145	13/2	2	58172402	D.12.01_0_40202	34	1
	A.01.01_1_48842	1.1	1		M.02.03_0_41409	13/2	1		D.12.01_1_40279	35	1
	A.01.02_0_48885	1.1	1		M.02.04_0_41480	13/2	1	58172447	D.12.01_0_40202	35	8
	A.01.02_1_45599	1.1	1		M.02.04_0_41480	14/2	1		D.12.01_1_40279	36	8
	A.01.03_0_48930	1.1	1	58172014	I.01.01_0_40883	11.2	1	58172448	D.12.01_0_40202	36	8
	A.01.03_1_45644	1.1	1		I.01.01_0_40883	5	1		D.12.01_1_40279	37	8
58171200	A.01.01_0_45556	1.2	1		L.02.02_0_40987	13/3	2	58172463	F.04.01_0_46735	7	2
	A.01.01_1_48842	1.2	1		L.02.05_0_41145	13/3	2	58172489	I.01.01_0_40883	8	1
	A.01.02_0_48885	1.2	1		M.02.03_0_41409	13/3	1		L.02.02_0_40987	15	1
	A.01.02_1_45599	1.2	1		M.02.04_0_41480	13/3	1		L.02.05_0_41145	16	1
	A.01.03_0_48930	1.2	1		M.02.04_0_41480	14/3	1	58172707	I.01.01_0_40883	2	1
	A.01.03_1_45644	1.2	1	58172015	L.02.02_0_40987	10	1	58173030	D.03.02_0_39758	5	1
58171536	L.01.01_0_40903	21.2	1		L.02.05_0_41145	10	1		D.03.02_1_39804	5	1
	M.01.01_0_41199	31.2	1	58172016	I.01.01_0_40883	12	1	58173072	T.02.02_0_41675	21.1	1
58171537	L.01.01_0_40903	21.1	1		L.02.02_0_40987	20	6	58173116	B.08.02_0_38771	19.1	2
	M.01.01_0_41199	31.1	1		L.02.05_0_41145	21	6		B.08.02_0_38771	20.1	2
58171737	F.03.04_0_40779	34.2	1		M.02.03_0_41409	20	3	58173119	B.08.02_0_38771	19.2	2
	F.03.04_1_40827	34.2	1		M.02.04_0_41480	20	3		B.08.02_0_38771	20.2	2
58171901	A.05.02_0_45864	22	1	58172017	I.01.01_0_40883	13	1	58173120	B.08.02_0_38771	19.3	1
	E.03.02_0_42668	12	4	58172018	I.01.01_0_40883	14	1	58173121	B.08.02_0_38771	20.3	1
58171925	I.01.01_0_40883	10	1	58172105	D.02.02_0_39318	32	5	58173195	D.03.02_0_39758	19.1	2
58172011	I.01.01_0_40883	1	1	58172106	D.02.02_0_39318	31	5		D.03.02_0_39758	31.1	2
	L.02.02_0_40987	12	2	58172240	I.01.01_0_40883	11.3	1		D.03.02_0_39758	37.1	4
	L.02.05_0_41145	12	1		I.01.01_0_40883	6	1		D.03.02_1_39804	16.1	2
	M.02.03_0_41409	14	1	58172267	B.08.02_0_38771	7.2	1		D.03.02_1_39804	28.1	2
58172012	I.01.01_0_40883	3	1		E.03.02_0_42668	1.2	1		D.03.02_1_39804	34.1	4

SPARE PARTS INSTANCE INDEX

Code	Parts Table	Pos.	Q.ty	Code	Parts Table	Pos.	Q.ty	Code	Parts Table	Pos.	Q.ty
58173361	I.01.01_0_40883	9	1	58175121	A.01.02_0_48885	33	1	58176323	W.01.03_0_44163	6.1	1
	L.02.02_0_40987	14	1		A.01.02_1_45599	33	1	58176324	W.01.03_0_44163	6.2	1
	L.02.05_0_41145	15	1		A.01.03_0_48930	33	1	58176336	F.01.03_0_51164	21	1
	M.02.03_0_41409	18	1		A.01.03_1_45644	33	1	58176337	F.01.03_0_51164	11	1
	M.02.04_0_41480	18	1	58175122	A.04.01_0_45765	1.5	1	58176396	E.03.02_0_42668	13	2
58173399	F.04.01_0_46735	10	1		A.04.02_0_45780	1.5	1	58176406	E.01.01_0_42630	7	2
58173437	B.12.04_0_51054	4	1		A.04.03_0_45796	1.5	1		E.03.02_0_42668	14	2
58173505	F.01.03_0_51164	10	1		A.04.04_0_45812	1.5	1	58176618	A.01.01_0_45556	30	1
58173664	D.02.02_0_39318	9	1	58175187	M.02.03_0_41409	45	2		A.01.01_1_48842	30	1
58173772	B.07.02_0_42592	25	1		M.02.04_0_41480	45	2		A.01.02_0_48885	30	1
58173773	B.07.02_0_42592	26	1	58175188	M.02.03_0_41409	44/2	1		A.01.02_1_45599	30	1
58173961	D.03.02_0_39758	4	1		M.02.04_0_41480	44/2	1		A.01.03_0_48930	30	1
58174192	D.07.02_0_39660	1	3	58175191	I.01.01_0_40883	15	1		A.01.03_1_45644	30	1
	D.07.02_1_39700	1	3		M.02.03_0_41409	32	1	58176755	A.04.01_0_45765	1	1
58174305	F.03.04_0_40779	34	2		M.02.04_0_41480	32	1		A.04.03_0_45796	1	1
	F.03.04_1_40827	34	2	58175209	C.01.02_0_39031	22	1	58176898	A.04.02_0_45780	1	1
58174417	D.03.02_0_39758	40	1	58175211	M.02.03_0_41409	44/1	1		A.04.04_0_45812	1	1
	D.03.02_1_39804	37	1		M.02.04_0_41480	44/1	1	58177182	F.02.01_0_51232	3	1
58174547	F.03.04_0_40779	22	1	58175630	W.01.03_0_44163	8.1	1	58177274	B.01.01_0_47067	3	1
	F.03.04_1_40827	22	1	58175676	F.04.01_0_46735	17	1	58177330	B.05.03_0_50689	25	2
58174555	B.11.01_0_38871	9	1	58175677	F.04.01_0_46735	15	1		B.05.04_0_50716	20	2
58174581	L.01.01_0_40903	11	1	58175700	E.03.02_0_42668	2	1	58177400	A.01.01_0_45556	27	1
	M.01.01_0_41199	12	1	58175769	B.08.02_0_38771	12	1		A.01.01_1_48842	27	1
58174608	A.03.01_0_45689	8	2	58175770	B.08.02_0_38771	13	1		A.01.02_0_48885	27	1
	A.03.02_0_45727	8	2	58175773	A.01.01_0_45556	21	1		A.01.02_1_45599	27	1
58174644	B.11.01_0_38871	39	2		A.01.01_1_48842	21	1		A.01.03_0_48930	27	1
58174732	F.04.01_0_46735	25	1		A.01.02_0_48885	21	1		A.01.03_1_45644	27	1
58174928	B.08.02_0_38771	14	1		A.01.02_1_45599	21	1	58177653	D.02.02_0_39318	2	1
58174974	I.01.01_0_40883	11	1		A.01.03_0_48930	21	1	58177722	B.12.03_0_46827	1	1
58175014	F.01.03_0_51164	14	2		A.01.03_1_45644	21	1	58177732	T.03.03_0_42459	2.1	1
58175083	L.02.02_0_40987	49	1	58175965	W.01.03_0_44163	1.2	1	58177736	T.03.03_0_42459	5	1
	M.02.03_0_41409	64	1	58175966	W.01.03_0_44163	8.2	1	58177737	T.03.03_0_42459	6	2
58175121	A.01.01_0_45556	33	1	58176271	W.01.04_0_45316	6/1	1	58177738	T.03.03_0_42459	7	2
	A.01.01_1_48842	33	1	58176272	W.01.04_0_45316	6/2	1	58177739	T.03.03_0_42459	8	6



SPARE PARTS INSTANCE INDEX

Code	Parts Table	Pos.	Q.ty	Code	Parts Table	Pos.	Q.ty	Code	Parts Table	Pos.	Q.ty
58177740	T.03.03_0_42459	9	2	58192377	B.12.04_0_51054	14	1	59073725	D.03.02_1_39804	16	1
58177741	T.03.03_0_42459	11	1	59070012	C.01.02_0_39031	14	1	59074081	D.03.02_0_39758	37	1
58177742	T.03.03_0_42459	12	2	59070051	D.15.04_0_40488	34	1		D.03.02_1_39804	34	1
58177743	T.03.03_0_42459	14	1	59070065	D.01.02_0_40152	22	1	59074206	D.03.02_0_39758	31	1
58177744	T.03.03_0_42459	15	1		D.09.02_0_39867	12	1		D.03.02_1_39804	28	1
58177745	T.03.03_0_42459	18	1	59070094	D.10.01_0_39887	13	1	59074213	A.02.02_0_42523	15/2	1
58177746	T.03.03_0_42459	19	1	59070289	L.01.01_0_40903	18	1	59074332	F.03.04_0_40779	5	1
58177754	D.03.02_1_39804	4	1		M.01.01_0_41199	28	1		F.03.04_1_40827	5	1
58177761	M.02.03_0_41409	41	1	59070290	L.01.01_0_40903	19	1	59074346	A.02.02_0_42523	11/1	1
	M.02.04_0_41480	41	1		M.01.01_0_41199	29	1	59074347	A.02.02_0_42523	15/1	1
58177867	B.08.02_0_38771	11	1	59070333	D.15.04_0_40488	6	1	59074403	B.11.01_0_38871	23	1
58177978	T.02.02_0_41675	12/2	2	59070448	T.02.01_0_41647	16	1	59074436	D.08.01_0_42969	9	1
58178571	W.01.04_0_45316	9/1	1		T.02.02_0_41675	26	1	59074438	D.08.01_0_42969	4	1
58178572	W.01.04_0_45316	9/2	1	59070591	B.03.03_0_50588	24	1	59074459	D.15.04_0_40488	25	1
58178585	A.03.02_0_45727	1	1	59070592	B.05.03_0_50689	17	1	59074468	B.11.01_0_38871	1	1
58178586	A.03.01_0_45689	1	1		B.05.04_0_50716	15	1	59074476V	B.11.01_0_38871	18	1
58178638	A.03.01_0_45689	34	1	59070702	T.03.01_0_41710	1	1	59074477V	B.11.01_0_38871	21	1
	A.03.02_0_45727	34	1	59070838	C.02.04_0_39172	16	2	59074482	F.03.04_0_40779	25	1
58178646	A.01.02_0_48885	2	1		C.02.04_1_39212	16	2		F.03.04_1_40827	25	1
	A.01.02_1_45599	2	1	59071241	B.12.03_0_46827	13	1	59074525V	B.11.01_0_38871	34	1
	A.01.03_0_48930	2	1	59071966	B.05.03_0_50689	24	1	59074546	F.03.04_0_40779	23	1
	A.01.03_1_45644	2	1	59072057	L.02.02_0_40987	19	4		F.03.04_1_40827	23	1
58178811	D.01.02_0_40152	1/2	1		L.02.05_0_41145	20	4	59074598	B.04.07_0_40076	1	1
58178873	D.01.02_0_40152	1/1	1		M.02.03_0_41409	19	2	59074599	B.04.07_0_40076	2	1
58178954	F.03.04_0_40779	1	1		M.02.04_0_41480	19	2	59074623	D.03.02_0_39758	13	1
	F.03.04_1_40827	1	1	59073184	A.04.02_0_45780	7	1		D.03.02_1_39804	12	1
58178960	D.15.04_0_40488	17	1		A.04.04_0_45812	7	1	59074662	B.02.01_0_47127	20	6
58179010	E.01.01_0_42630	2	2	59073242	D.15.04_0_40488	31	1		B.02.01_1_47161	20	6
58179413	E.01.01_0_42630	8	2	59073674	B.04.07_0_40076	6	1	59074741	D.03.02_0_39758	8	1
58179414	B.03.03_0_50588	11	2	59073678	B.04.07_0_40076	5	1	59074744	F.04.01_0_46735	19	1
	B.03.04_0_50621	11	2	59073681	A.02.02_0_42523	11/2	1	59074748	F.04.01_0_46735	23	1
58179463	F.01.03_0_51164	1	1	59073685	D.03.02_0_39758	25	1	59074749	F.04.01_0_46735	24	1
	F.02.01_0_51232	1	1		D.03.02_1_39804	22	1	59074754	L.02.02_0_40987	7	1
58192377	B.12.03_0_46827	3	1	59073725	D.03.02_0_39758	19	1		L.02.05_0_41145	7	1

SPARE PARTS INSTANCE INDEX

Code	Parts Table	Pos.	Q.ty	Code	Parts Table	Pos.	Q.ty	Code	Parts Table	Pos.	Q.ty
59074759	L.02.02_0_40987	26	1	59075813	C.02.04_1_39212	20	1	59076685	A.05.02_0_45864	12	1
	L.02.05_0_41145	27	1	59075840	T.02.01_0_41647	6	1	59076686	A.05.02_0_45864	26	1
59074993	D.12.01_0_40202	63	1	59075850	T.02.02_0_41675	13	1		B.02.01_0_47127	6	1
	D.12.01_1_40279	64	1	59075885	T.02.02_0_41675	14	1		B.02.01_1_47161	6	1
59075012	T.03.02_0_41719	1.1	1	59075917	F.04.01_0_46735	22	1	59076688	A.01.01_0_45556	16	1
59075037	L.02.02_0_40987	25	1	59075979	M.02.03_0_41409	28	1		A.01.01_1_48842	16	1
	L.02.05_0_41145	26	1		M.02.04_0_41480	28	1		A.01.02_0_48885	16	1
59075039	L.02.02_0_40987	27	1	59076085	L.01.01_0_40903	12	1		A.01.02_1_45599	16	1
	L.02.05_0_41145	28	1		M.01.01_0_41199	13	1		A.01.03_0_48930	16	1
	M.02.03_0_41409	24	1	59076100	T.02.02_0_41675	8	2		A.01.03_1_45644	16	1
	M.02.04_0_41480	24	1	59076211	F.01.03_0_51164	4	1	59076690	B.03.03_0_50588	19	2
59075137	M.01.01_0_41199	60	1	59076212	F.01.03_0_51164	20	2	59076756	B.01.01_0_47067	21	1
59075140	M.01.01_0_41199	55	1	59076213	F.01.03_0_51164	12	1	59076780	B.05.03_0_50689	14	1
59075148	M.01.01_0_41199	19	1	59076224	F.01.03_0_51164	27	1		B.05.04_0_50716	12	1
59075169	M.02.03_0_41409	7	1	59076225	F.01.03_0_51164	26	1	59076902	B.03.03_0_50588	28	1
	M.02.04_0_41480	7	1	59076226	F.01.03_0_51164	23	1	59076903	B.03.03_0_50588	29	1
59075171	M.02.03_0_41409	49	1	59076612	B.03.03_0_50588	18	1	59077055	B.03.04_0_50621	15	1
	M.02.04_0_41480	49	1	59076614	B.03.03_0_50588	16	1	59077056	B.03.04_0_50621	16	1
59075178	M.01.01_0_41199	61	1	59076616	B.03.03_0_50588	15	1	59077228	D.15.04_0_40488	1	1
59075224	F.03.04_0_40779	36	1	59076619	A.01.02_0_48885	32	1	59077233	D.15.04_0_40488	29	1
	F.03.04_1_40827	36	1		A.01.02_1_45599	32	1	59077234	D.15.04_0_40488	27	1
59075225	F.03.04_0_40779	37	1		A.01.03_0_48930	32	1	59077242	E.03.02_0_42668	17	1
	F.03.04_1_40827	37	1		A.01.03_1_45644	32	1	59077318	A.01.01_0_45556	12	1
59075254	M.02.03_0_41409	37	1	59076620	A.01.01_0_45556	32	1		A.01.01_1_48842	12	1
	M.02.04_0_41480	37	1		A.01.01_1_48842	32	1		A.01.02_0_48885	12	1
59075283	B.01.01_0_47067	28	1	59076641V	B.03.03_0_50588	2	1		A.01.02_1_45599	12	1
59075360	L.02.02_0_40987	32	1		B.03.04_0_50621	2	1		A.01.03_0_48930	12	1
	L.02.05_0_41145	33	1	59076645V	B.03.03_0_50588	1	1		A.01.03_1_45644	12	1
59075572	D.13.01_0_40355	21	1		B.03.04_0_50621	1	1	59077359	B.05.03_0_50689	18	1
59075678	F.04.01_0_46735	12	1	59076679	A.05.02_0_45864	23	1	59077445V	B.05.03_0_50689	3	1
59075679	F.04.01_0_46735	28	1	59076682	A.01.02_1_45599	36	1		B.05.04_0_50716	1	1
59075716	B.04.07_0_40076	34	1		A.01.03_1_45644	36	1	59077449V	B.05.03_0_50689	4	1
59075791	T.02.01_0_41647	5	1	59076684	A.03.01_0_45689	13	1		B.05.04_0_50716	2	1
59075813	C.02.04_0_39172	20	1		A.03.02_0_45727	13	1	59077474	B.05.03_0_50689	20	2

SPARE PARTS INSTANCE INDEX

Code	Parts Table	Pos.	Q.ty	Code	Parts Table	Pos.	Q.ty	Code	Parts Table	Pos.	Q.ty
59077474	B.05.04_0_50716	17	2	59277415	W.01.04_0_45316	1/1	1	59900344	A.01.01_0_45556	1.3	1
59077480	A.01.01_0_45556	35	1	59278554	D.03.02_0_39758	1	1		A.01.01_1_48842	1.3	1
	A.01.02_0_48885	36	1		D.03.02_1_39804	1	1		A.01.02_0_48885	1.3	1
	A.01.03_0_48930	36	1	59278555	D.03.02_0_39758	2	1		A.01.02_1_45599	1.3	1
59077934	A.05.02_0_45864	13	1		D.03.02_1_39804	2	1		A.01.03_0_48930	1.3	1
59077935	A.05.02_0_45864	17	1	59375009	T.03.02_0_41719	1	1		A.01.03_1_45644	1.3	1
59078588	L.01.01_0_40903	30	1	59376075	D.12.01_0_40202	31	1	59900345	A.01.01_0_45556	1.5	1
59078595	F.01.03_0_51164	24	1	59376519	D.01.02_0_40152	12	1		A.01.01_1_48842	1.5	1
59078865	D.13.01_0_40355	22	1	59377433	D.12.01_0_40202	56	1		A.01.02_0_48885	1.5	1
59079167	A.01.01_0_45556	6	1		D.12.01_1_40279	57	1		A.01.02_1_45599	1.5	1
	A.01.01_1_48842	6	1	59377730	T.03.03_0_42459	2	1		A.01.03_0_48930	1.5	1
	A.01.02_0_48885	6	1	59377734	T.03.03_0_42459	1	1		A.01.03_1_45644	1.5	1
	A.01.02_1_45599	6	1	59378814	D.09.02_0_39867	4	1	59900347	A.04.01_0_45765	1.2	1
	A.01.03_0_48930	6	1	59900152	B.12.03_0_46827	15	1		A.04.02_0_45780	1.2	1
	A.01.03_1_45644	6	1	59900153	B.12.03_0_46827	9	1		A.04.03_0_45796	1.2	1
59079186	T.02.02_0_41675	2	1	59900154	B.12.03_0_46827	8	4		A.04.04_0_45812	1.2	1
59079187	T.02.02_0_41675	3	1	59900155	B.12.03_0_46827	7/1	1	59900353	A.04.01_0_45765	1.1	1
59079478	F.02.01_0_51232	12	1	59900156	B.12.03_0_46827	6	1		A.04.02_0_45780	1.1	1
59079479	F.01.03_0_51164	3	1	59900157	B.12.03_0_46827	10	1		A.04.03_0_45796	1.1	1
59270304	W.01.03_0_44163	1/1	1	59900158	B.12.03_0_46827	10	18		A.04.04_0_45812	1.1	1
59271011	F.04.01_0_46735	8	1	59900159	B.12.03_0_46827	5	1	59900361	W.01.03_0_44163	1.3	1
59272073	D.08.01_0_42969	7	1	59900160	B.12.03_0_46827	12	1		W.01.03_0_44163	6.3	1
59273925	W.01.03_0_44163	1/2	1	59900161	B.12.03_0_46827	14	1		W.01.03_0_44163	8.3	1
59275632	W.01.03_0_44163	8/1	1	59900183	B.12.04_0_51054	5	1	59900376	D.12.01_0_40202	12	1
59275633	W.01.03_0_44163	8/2	1	59900184	B.12.04_0_51054	6	1		D.12.01_1_40279	12	1
59276002	C.02.04_0_39172	24	1	59900185	B.12.04_0_51054	7	1	59900766	A.01.01_0_45556	1.4	1
	C.02.04_1_39212	24	1	59900186	B.12.04_0_51054	8	1		A.01.01_1_48842	1.4	1
59276003	C.02.04_0_39172	1	1	59900187	B.12.04_0_51054	9	1		A.01.02_0_48885	1.4	1
	C.02.04_1_39212	1	1	59900199	B.12.04_0_51054	1	1		A.01.02_1_45599	1.4	1
59276076	D.12.01_0_40202	47	1	59900230	I.01.01_0_40883	10.1	1		A.01.03_0_48930	1.4	1
	D.12.01_1_40279	48	1		I.01.01_0_40883	11.1	1		A.01.03_1_45644	1.4	1
59276320	W.01.03_0_44163	6/1	1	59900242	E.03.02_0_42668	1.3	1	59900915	B.02.01_0_47127	1/2	1
59276321	W.01.03_0_44163	6/2	1	59900340	F.03.04_0_40779	34.1	1	59900916	B.02.01_0_47127	1/1	1
59277414	W.01.04_0_45316	1/2	1		F.03.04_1_40827	34.1	1	59900917	B.02.01_0_47127	1/4	1

SPARE PARTS INSTANCE INDEX

Code	Parts Table	Pos.	Q.ty	Code	Parts Table	Pos.	Q.ty	Code	Parts Table	Pos.	Q.ty
59900918	B.02.01_0_47127	1/3	1	F0256910010	B.05.04_0_50716	9	1	F0801331150	D.04.01_1_42845	7	2
59900919	B.02.01_0_47127	1/6	1	F0801022000	T.03.03_0_42459	16	1	F0801353000	D.04.01_0_42820	12	1
59900920	B.02.01_0_47127	1/5	1	F0801028000	T.03.03_0_42459	10	6		D.04.01_1_42845	12	1
59900975	B.02.01_1_47161	1/1	1	F0801050000	M.01.01_0_41199	23	1		D.12.01_0_40202	9	1
59900976	B.02.01_1_47161	1/3	1	F0801095000	D.15.04_0_40488	24	1		D.12.01_1_40279	9	1
59900977	B.02.01_1_47161	1/5	1	F0801163000	F.03.04_0_40779	31	1	F0801380100	D.04.01_0_42820	16	2
59900978	B.02.01_1_47161	1/7	1		F.03.04_1_40827	31	1		D.04.01_1_42845	16	2
59900979	B.02.01_1_47161	1/9	1	F0801241010	D.05.01_0_42870	4	4	F0801422010	D.01.02_0_40152	10	2
59900980	B.02.01_1_47161	1/11	1		D.05.01_1_42883	4	4	F0801455100	D.02.02_0_39318	34	1
59900981	B.02.01_1_47161	1/2	1		D.12.01_1_40279	15	1	F0802104000	D.09.02_0_39867	1	1
59900982	B.02.01_1_47161	1/4	1		D.15.04_0_40488	4	2	F0802163010	D.02.02_0_39318	13	1
59900983	B.02.01_1_47161	1/6	1		L.01.01_0_40903	23	2	F0802228005	D.12.01_0_40202	28	1
59900984	B.02.01_1_47161	1/8	1		M.01.01_0_41199	33	2		D.12.01_1_40279	29	1
59900985	B.02.01_1_47161	1/10	1	F0801244080	D.12.01_0_40202	24	2	F0802239045	D.01.02_0_40152	7	1
59900986	B.02.01_1_47161	1/12	1	F0801248000	D.12.01_0_40202	12.3	1	F0802700150	D.10.01_0_39887	1	1
59901049	B.12.03_0_46827	4	1		D.12.01_1_40279	12.3	1	F0803050000	D.08.01_0_42969	10	1
59901050	B.12.03_0_46827	2	1	F0801264050	D.02.02_0_39318	14	1		F.03.04_0_40779	24	1
59901086	E.01.01_0_42630	8.1	2		D.04.01_0_42820	1	1		F.03.04_1_40827	24	1
59901087	E.03.02_0_42668	13.1	2		D.04.01_1_42845	1	1	F0803057000	D.03.02_0_39758	16	2
59978093	D.12.01_0_40202	50	1	F0801266100	D.02.02_0_39318	22	1		D.03.02_1_39804	15	2
F0150010905	W.01.03_0_44163	11	1	F0801282000	L.02.02_0_40987	44	12	F0803078100	D.01.02_0_40152	5	1
	W.01.04_0_45316	10	1		L.02.05_0_41145	45	12	F0803185000	L.02.02_0_40987	2	1
F0150036216	B.12.04_0_51054	2	1		M.02.03_0_41409	59	8		L.02.05_0_41145	2	1
F0150036219	B.12.04_0_51054	3	1		M.02.04_0_41480	59	6		M.02.03_0_41409	2	1
F0190018909	E.02.01_0_46767	2	1	F0801282050	D.12.01_0_40202	44	1		M.02.04_0_41480	2	1
F0256808000	A.05.02_0_45864	31	1		D.12.01_1_40279	45	1	F0803186000	D.08.01_0_42969	6	1
	B.03.03_0_50588	30	1	F0801297050	D.12.01_0_40202	48	1	F0803199010	D.12.01_0_40202	65	1
	B.04.07_0_40076	27	1		D.12.01_1_40279	49	1		D.12.01_1_40279	66	1
F0256809010	B.11.01_0_38871	3	1	F0801299100	D.06.01_0_42896	20	2	F0803209000	D.11.01_0_40184	4	1
F0256809050	A.03.01_0_45689	6	1		D.06.01_1_42932	21	2	F0803209070	C.01.02_0_39031	13	1
	A.03.02_0_45727	6	1	F0801310600	C.01.02_0_39031	21	1	F0803259000	C.01.02_0_39031	12	1
F0256909000	F.03.04_1_40827	53	1	F0801331050	L.01.01_0_40903	20	2	F0808060100	T.03.01_0_41710	2	1
F0256910000	B.03.03_0_50588	31	1		M.01.01_0_41199	30	2	F0808518050	B.07.02_0_42592	29	4
F0256910010	B.05.03_0_50689	11	1	F0801331150	D.04.01_0_42820	7	2	F0810510000	D.03.02_0_39758	27	2

SPARE PARTS INSTANCE INDEX

Code	Parts Table	Pos.	Q.ty	Code	Parts Table	Pos.	Q.ty	Code	Parts Table	Pos.	Q.ty
F0810510000	D.03.02_1_39804	24	2	F0812899000	D.06.01_0_42896	2	1	F0814632000	C.01.02_0_39031	10	2
	D.14.01_0_40378	6	2		D.06.01_1_42932	2	1	F0814750010	C.03.02_0_39268	9	16
	D.15.04_0_40488	12	4	F0812918010	D.04.01_0_42820	22	1	F0814794000	B.03.03_0_50588	23	2
F0810527000	D.03.02_0_39758	35	1		D.04.01_1_42845	22	1	F0817500200	A.01.01_0_45556	29	1
	D.03.02_1_39804	32	2		D.12.01_0_40202	26	3		A.01.01_1_48842	29	1
F0812523050	D.02.02_0_39318	1	1		D.12.01_1_40279	27	3		A.01.02_0_48885	29	1
F0812599086	D.12.01_0_40202	12.1	1	F0812951070	D.06.01_0_42896	5	2		A.01.02_1_45599	29	1
	D.12.01_1_40279	12.1	1		D.06.01_1_42932	5	2		A.01.03_0_48930	29	1
F0812637000	D.12.01_0_40202	2	2	F0812951200	D.04.01_0_42820	15	2		A.01.03_1_45644	29	1
	D.12.01_1_40279	2	2		D.04.01_1_42845	15	2		A.03.01_0_45689	31	4
F0812660020	D.04.01_0_42820	21	1	F0812951300	D.12.01_0_40202	20	1		A.03.02_0_45727	31	4
	D.04.01_1_42845	21	1		D.12.01_1_40279	21	1		A.05.02_0_45864	20	4
F0812689050	D.12.01_0_40202	12.2	1	F0812956000	D.01.02_0_40152	14	2	F0817500400	A.01.01_0_45556	28	3
	D.12.01_1_40279	12.2	1		D.09.02_0_39867	13	2		A.01.01_1_48842	28	3
F0812692015	D.06.01_0_42896	15	1	F0812957000	D.06.01_0_42896	13	1		A.01.02_0_48885	28	3
	D.06.01_1_42932	16	1		D.06.01_1_42932	14	1		A.01.02_1_45599	28	3
F0812708030	D.05.01_0_42870	2	1	F0812957010	D.12.01_0_40202	11	1		A.01.03_0_48930	28	3
	D.05.01_1_42883	2	1		D.12.01_1_40279	11	1		A.01.03_1_45644	28	3
F0812736010	D.12.01_0_40202	30	1	F0812975250	D.10.01_0_39887	2	2		A.03.01_0_45689	33	2
	D.12.01_1_40279	31	1	F0814545000	A.03.01_0_45689	20	2		A.03.02_0_45727	33	2
F0812783000	D.04.01_0_42820	19	1		A.03.02_0_45727	20	2	F0817500470	A.03.01_0_45689	25	2
	D.04.01_1_42845	19	1	F0814547000	B.02.01_1_47161	26	8		A.03.02_0_45727	25	2
F0812784000	D.12.01_0_40202	17	2		C.02.04_0_39172	31	4	F0817500500	A.03.01_0_45689	22	1
	D.12.01_1_40279	18	2		C.02.04_1_39212	31	4		A.03.02_0_45727	22	1
F0812811000	D.06.01_0_42896	19	2	F0814569000	B.01.01_0_47067	20	1	F0817500700	A.03.01_0_45689	24	1
	D.06.01_1_42932	20	2		D.03.02_0_39758	22	2		A.03.02_0_45727	24	1
F0812838000	C.02.04_0_39172	12	2		D.03.02_1_39804	19	2	F0817500800	A.04.03_0_45796	9	1
	C.02.04_1_39212	12	2		M.01.01_0_41199	24	5		A.04.04_0_45812	10	1
F0812859000	D.01.02_0_40152	9	2	F0814585000	B.02.01_0_47127	5	3	F0817500900	A.04.03_0_45796	10	1
F0812868000	D.04.01_0_42820	2	1		B.02.01_1_47161	5	3		A.04.04_0_45812	11	1
	D.04.01_1_42845	2	1		B.11.01_0_38871	8	1	F0817501000	A.04.01_0_45765	9	2
F0812868100	D.02.02_0_39318	17	1	F0814627000	D.15.04_0_40488	16	1		A.04.02_0_45780	10	2
F0812878040	D.04.01_0_42820	4	2	F0814632000	A.03.01_0_45689	10	4	F0817501200	A.04.01_0_45765	7	1
	D.04.01_1_42845	4	2		A.03.02_0_45727	10	4		A.04.03_0_45796	7	1

SPARE PARTS INSTANCE INDEX

Code	Parts Table	Pos.	Q.ty	Code	Parts Table	Pos.	Q.ty	Code	Parts Table	Pos.	Q.ty
F0817503000	F.01.03_0_51164	9	12	F0824185000	F.04.01_0_46735	16	1	F0828029070	A.02.02_0_42523	1	1
F0817640003	D.07.02_0_39660	4	3	F0825115010	B.08.02_0_38771	10	1	F0828468050	D.13.01_0_40355	12	2
	D.07.02_1_39700	5	3	F0825139000	E.03.02_0_42668	1.4	1	F0831047000	D.13.01_0_40355	9	1
F0822537050	D.03.02_0_39758	32	1	F0825400060	B.08.02_0_38771	9	1	F0831065000	B.01.01_0_47067	13	1
	D.03.02_1_39804	29	1	F0825403050	B.08.02_0_38771	18	1	F0831125000	A.02.02_0_42523	14	2
	D.15.04_0_40488	2	2	F0825414000	A.05.02_0_45864	25	2	F0835031010	F.03.04_0_40779	19	4
F0824022000	L.02.02_0_40987	5	1	F0825417000	E.02.01_0_46767	8	1		F.03.04_1_40827	19	4
	L.02.05_0_41145	5	1	F0825436000	B.08.02_0_38771	7.3	1	F0835037000	L.02.02_0_40987	42	5
	M.02.03_0_41409	5	1		E.03.02_0_42668	1.5	1		L.02.05_0_41145	43	6
	M.02.04_0_41480	5	1	F0825436003	B.08.02_0_38771	7.4	1		M.02.03_0_41409	57	3
F0824110000	D.03.02_0_39758	18	2		E.03.02_0_42668	1.6	1		M.02.04_0_41480	57	3
	F.03.04_1_40827	52	2	F0825438000	E.03.02_0_42668	5	1	F0835040030	F.03.04_0_40779	18	2
	F.04.01_0_46735	21	2	F0825480100	E.02.01_0_46767	1	1		F.03.04_1_40827	18	2
	L.02.02_0_40987	30	23	F0825488000	E.03.02_0_42668	9	2	F0835523000	D.03.02_0_39758	29	1
	L.02.05_0_41145	31	24	F0825493000	E.03.02_0_42668	18	1		D.03.02_1_39804	26	1
	M.02.03_0_41409	11	15	F0825500220	B.08.02_0_38771	8.1	1	F0837521000	B.11.01_0_38871	43	1
	M.02.04_0_41480	11	15	F0825718020	F.01.03_0_51164	14.1	2	F0837534010	L.02.02_0_40987	18	4
F0824113000	C.03.02_0_39268	15	1	F0825809000	L.02.02_0_40987	1	1		L.02.05_0_41145	19	4
	F.02.01_0_51232	14	2		L.02.05_0_41145	1	1		M.02.03_0_41409	17	2
	F.03.04_0_40779	42	2		M.02.03_0_41409	1	1		M.02.04_0_41480	17	2
	F.03.04_1_40827	42	2		M.02.04_0_41480	1	1	F0838154010	D.12.01_0_40202	58	2
	L.02.02_0_40987	37	4	F0825980030	L.02.02_0_40987	45	6		D.12.01_1_40279	59	2
	L.02.05_0_41145	38	4		L.02.05_0_41145	46	6	F0838384000	A.01.01_0_45556	36	1
	M.02.03_0_41409	53	4		M.02.03_0_41409	60	4		A.01.02_0_48885	38	1
	M.02.04_0_41480	53	4		M.02.04_0_41480	60	3		A.01.03_0_48930	38	1
F0824141000	F.03.04_0_40779	14	8	F0826039000	D.03.02_0_39758	34	1	F0838475000	C.01.02_0_39031	9	2
	F.03.04_1_40827	14	8		D.03.02_1_39804	31	2	F0842512000	F.03.04_0_40779	12	2
	L.02.02_0_40987	43	5	F0826056000	C.02.04_0_39172	7	2		F.03.04_1_40827	12	2
	L.02.05_0_41145	44	6		C.02.04_0_39172	8	1	F0843102000	D.08.01_0_42969	11	1
	M.02.03_0_41409	31	4		C.02.04_1_39212	7	2	F0843107000	F.03.04_1_40827	49	1
	M.02.03_0_41409	58	5		L.01.01_0_40903	6	1		F.04.01_0_46735	13	8
	M.02.04_0_41480	31	4		M.01.01_0_41199	7	3	F0843109000	F.03.04_0_40779	43	2
	M.02.04_0_41480	58	3		T.02.02_0_41675	4	2		F.03.04_1_40827	45	2
F0824185000	F.01.03_0_51164	22	1		T.03.02_0_41719	1.2	1	F0843109020	D.03.02_0_39758	17	1

SPARE PARTS INSTANCE INDEX

Code	Parts Table	Pos.	Q.ty	Code	Parts Table	Pos.	Q.ty	Code	Parts Table	Pos.	Q.ty
F0843109020	F.03.04_1_40827	51	1	F0843570000	C.01.02_0_39031	26	8	F0843643060	D.15.04_0_40488	22	7
	F.04.01_0_46735	20/1	1		F.02.01_0_51232	7	4		F.01.03_0_51164	17	14
	L.02.02_0_40987	28	7		F.03.04_0_40779	39	1		F.03.04_0_40779	27	2
	L.02.05_0_41145	29	7		F.03.04_0_40779	8	4		F.03.04_1_40827	27	2
	M.02.03_0_41409	10	4		F.03.04_1_40827	39	1		F.04.01_0_46735	3	2
	M.02.04_0_41480	10	4		F.03.04_1_40827	8	2		L.01.01_0_40903	10	2
F0843110010	F.03.04_0_40779	41	1	F.04.01_0_46735	6	3	L.01.01_0_40903	26	2		
	F.03.04_1_40827	41	1	M.01.01_0_41199	57	2	L.02.02_0_40987	9	13		
	L.02.02_0_40987	36	2	M.01.01_0_41199	63	1	L.02.05_0_41145	9	13		
	L.02.05_0_41145	37	2	F0843581010	D.03.02_0_39758	7	2	M.01.01_0_41199	11	2	
	M.02.03_0_41409	25	1	D.03.02_1_39804	7	2	M.01.01_0_41199	36	2		
	M.02.03_0_41409	52	2	F0843641000	D.03.02_0_39758	11	2	M.02.03_0_41409	9	14	
	M.02.04_0_41480	25	1	D.03.02_1_39804	10	1	M.02.04_0_41480	9	14		
	M.02.04_0_41480	52	2	D.12.01_0_40202	62	1	T.02.01_0_41647	14	2		
F0843116000	F.03.04_0_40779	13	4	D.12.01_1_40279	63	1	T.02.02_0_41675	24	2		
	F.03.04_1_40827	13	4	F0843643060	A.01.01_0_45556	4	7	F0843696000	B.12.04_0_51054	12	6
	L.02.02_0_40987	48	1	A.01.01_1_48842	4	7	F0843711000	D.15.04_0_40488	35	4	
	M.02.03_0_41409	30	2	A.01.02_0_48885	4	7	F0843755000	A.01.01_0_45556	11	6	
	M.02.03_0_41409	63	1	A.01.02_1_45599	4	7	A.01.01_1_48842	11	6		
	M.02.04_0_41480	30	2	A.01.03_0_48930	4	7	A.01.02_0_48885	11	6		
F0843561000	A.02.02_0_42523	24	1	A.01.03_1_45644	4	7	A.01.02_1_45599	11	6		
	F0843570000	A.01.01_0_45556	24	2	A.02.02_0_42523	5	5	A.01.03_0_48930	11	6	
	A.01.01_1_48842	24	2	A.03.01_0_45689	17	3	A.01.03_1_45644	11	6		
	A.01.02_0_48885	24	2	A.03.02_0_45727	17	3	A.03.01_0_45689	9	5		
	A.01.02_1_45599	24	2	A.05.02_0_45864	30	1	A.03.02_0_45727	9	5		
	A.01.03_0_48930	24	2	B.01.01_0_47067	19	1	A.05.02_0_45864	15	2		
	A.01.03_1_45644	24	2	B.02.01_0_47127	9	6	B.04.07_0_40076	9	7		
	A.03.01_0_45689	3	6	B.02.01_1_47161	9	6	C.01.02_0_39031	11	12		
	A.03.02_0_45727	3	6	B.04.07_0_40076	26	14	E.02.01_0_46767	6	1		
	A.05.02_0_45864	28	2	B.11.01_0_38871	15	16	F.01.03_0_51164	19	4		
	B.01.01_0_47067	23	12	C.02.04_0_39172	18	2	F.02.01_0_51232	10	2		
	B.02.01_0_47127	15	2	C.02.04_0_39172	23	2	F.03.04_0_40779	4	6		
	B.02.01_1_47161	15	2	C.02.04_1_39212	18	2	F.03.04_1_40827	4	6		
	B.04.07_0_40076	20	4	C.02.04_1_39212	23	2	M.01.01_0_41199	48	2		

SPARE PARTS INSTANCE INDEX

Code	Parts Table	Pos.	Q.ty	Code	Parts Table	Pos.	Q.ty	Code	Parts Table	Pos.	Q.ty
F0843755000	T.02.02_0_41675	18	2	F0844150000	W.01.04_0_45316	3	4	F0850100020	D.05.01_0_42870	1	1
F0843771000	D.07.02_0_39660	14	5	F0844240000	C.02.04_0_39172	19	2		D.05.01_1_42883	1	1
	D.07.02_1_39700	15	5		C.02.04_1_39212	19	2	F0851044000	D.01.02_0_40152	24	3
	D.08.01_0_42969	12	2	F0844273090	C.01.02_0_39031	5	2	F0851156000	D.07.02_0_39660	32	4
	F.04.01_0_46735	18	3		C.03.02_0_39268	5	1		D.07.02_1_39700	33	4
F0843815000	F.02.01_0_51232	11	2		D.10.01_0_39887	16	1	F0851180000	D.13.01_0_40355	16	2
F0843818000	B.04.07_0_40076	11	6		L.02.02_0_40987	50	1	F0851226000	D.12.01_0_40202	57	1
F0843841000	D.03.02_0_39758	3	2		L.02.05_0_41145	49	1		D.12.01_1_40279	58	1
	D.03.02_1_39804	3	2		M.02.03_0_41409	65	1	F0851260000	D.11.01_0_40184	16	1
	F.04.01_0_46735	11	1		M.02.04_0_41480	63	1	F0851262000	D.07.02_0_39660	33	4
F0843843060	T.02.01_0_41647	8	4	F0847434000	D.07.02_0_39660	36	5		D.07.02_1_39700	34	4
	T.02.02_0_41675	16	4		D.07.02_1_39700	38	5	F0851267050	D.07.02_0_39660	34	3
F0843907000	D.03.02_0_39758	9	4		D.13.01_0_40355	19	2		D.07.02_1_39700	35	3
	D.03.02_1_39804	8	2	F0847462000	D.13.01_0_40355	8	1		D.11.01_0_40184	11	1
	F.01.03_0_51164	8	1	F0848655000	W.01.03_0_44163	10	1	F0851486000	L.01.01_0_40903	31	1
	F.03.04_0_40779	20	4	F0848655100	W.01.03_0_44163	13	1		M.01.01_0_41199	54	1
	F.03.04_1_40827	20	4	F0848664000	W.01.03_0_44163	5	1		T.02.01_0_41647	10.2	3
	F.03.04_1_40827	50	2	F0848672100	W.01.04_0_45316	8	1		T.02.02_0_41675	19.2	4
	F.04.01_0_46735	14	16	F0848676050	W.01.03_0_44163	7	1		T.02.02_0_41675	7	4
F0843921030	B.01.01_0_47067	26	2	F0848679600	W.01.03_0_44163	12	1		T.03.01_0_41710	5	4
F0843948000	F.03.04_0_40779	33	4	F0848681600	W.01.04_0_45316	11	1		T.03.02_0_41719	3	4
	F.03.04_1_40827	33	4	F0848681605	W.01.04_0_45316	12	1	F0851497000	B.01.01_0_47067	29	1
	F.04.01_0_46735	9	1	F0848844000	W.01.04_0_45316	7	1		T.03.01_0_41710	3	1
F0843957000	D.08.01_0_42969	2	2	F0848855000	W.01.03_0_44163	9	1	F0852107050	T.02.01_0_41647	4.1	1
F0843993060	W.01.03_0_44163	17	4	F0848920000	W.01.03_0_44163	4	1	F0852516020	B.11.01_0_38871	19	1
	W.01.04_0_45316	16	4		W.01.04_0_45316	4	1	F0852538050	F.01.03_0_51164	7	1
F0844030070	A.01.01_0_45556	22	1	F0849206005	A.03.01_0_45689	19	1	F0852550010	L.02.02_0_40987	46/1	2
	A.01.01_1_48842	22	1		A.03.02_0_45727	19	1		L.02.05_0_41145	47/1	2
	A.01.02_0_48885	22	1	F0849500001	A.05.02_0_45864	1.1	1	F0852550020	L.02.02_0_40987	46/2	2
	A.01.02_1_45599	22	1	F0849500002	A.05.02_0_45864	1.2	1		L.02.05_0_41145	47/2	2
	A.01.03_0_48930	22	1	F0850100000	D.05.01_0_42870	1	1		M.02.03_0_41409	61/1	2
	A.01.03_1_45644	22	1		D.05.01_1_42883	1	1		M.02.04_0_41480	61/1	2
F0844084000	W.01.04_0_45316	1.4	5	F0850100010	D.05.01_0_42870	1	1	F0852550030	L.02.02_0_40987	46/3	1
F0844150000	W.01.03_0_44163	3	4		D.05.01_1_42883	1	1		L.02.05_0_41145	47/3	2

SPARE PARTS INSTANCE INDEX

Code	Parts Table	Pos.	Q.ty	Code	Parts Table	Pos.	Q.ty	Code	Parts Table	Pos.	Q.ty
F0852550030	M.02.03_0_41409	61/2	1	F0862479020	B.08.02_0_38771	16	4	F0863267050	C.02.04_0_39172	6	8
	M.02.04_0_41480	61/2	1		B.11.01_0_38871	21	8		C.02.04_1_39212	6	8
F0852550040	L.02.02_0_40987	46/4	1	F0862479034	B.04.07_0_40076	31	1	F0863302000	T.02.02_0_41675	9	2
	M.02.03_0_41409	61/3	1	F0862479035	A.01.01_0_45556	5	1	F0863311250	D.01.02_0_40152	13	8
F0852578060	D.07.02_0_39660	39	1		A.01.01_1_48842	5	1		D.09.02_0_39867	5	8
	D.07.02_1_39700	41	1		A.01.02_0_48885	5	1	F0863429000	L.01.01_0_40903	4	4
	D.12.01_1_40279	48.1	2		A.01.02_1_45599	5	1		M.01.01_0_41199	4	4
F0858520000	A.02.02_0_42523	7	1		A.01.03_0_48930	5	1	F0863586000	B.11.01_0_38871	29	6
F0860058010	D.03.02_0_39758	38	1		A.01.03_1_45644	5	1	F0863672010	T.03.03_0_42459	13	1
	D.03.02_1_39804	35	1		B.04.07_0_40076	19	4	F0863890010	C.01.02_0_39031	19	16
F0860058020	D.03.02_0_39758	39	1		B.04.07_0_40076	30	3		C.03.02_0_39268	13	16
	D.03.02_1_39804	36	1	F0862481000	A.05.02_0_45864	18	2	F0863925000	C.02.04_0_39172	2	7
F0860091020	D.15.04_0_40488	32	1		M.02.03_0_41409	35	1		C.02.04_1_39212	2	7
F0861867001	B.08.02_0_38771	22	3		M.02.04_0_41480	35	1	F0863951000	C.02.04_0_39172	4	1
F0861867050	A.05.02_0_45864	4	6	F0862495010	B.12.04_0_51054	11	4		C.02.04_1_39212	4	1
F0861928050	B.11.01_0_38871	31	4	F0862549000	D.08.01_0_42969	14	2	F0863997010	C.02.04_0_39172	3	1
F0861941000	E.03.02_0_42668	6	3	F0862593050	M.01.01_0_41199	52	1		C.02.04_1_39212	3	1
F0861973000	M.02.03_0_41409	40	4	F0862655000	D.08.01_0_42969	13	2	F0864180000	T.03.01_0_41710	8	8
	M.02.04_0_41480	40	4		D.10.01_0_39887	14	4		T.03.02_0_41719	6	8
F0862129000	F.03.04_0_40779	45	2	F0862657000	D.02.02_0_39318	10	1	F0864222010	C.01.02_0_39031	17	16
	F.03.04_1_40827	44	2	F0862694000	A.01.02_0_48885	3	3		T.03.03_0_42459	3	8
F0862345000	D.03.02_0_39758	6	2		A.01.02_1_45599	3	3	F0864314000	W.01.03_0_44163	16	4
	D.03.02_1_39804	6	2		A.01.03_0_48930	3	3		W.01.04_0_45316	15	4
	F.04.01_0_46735	5	2		A.01.03_1_45644	3	3	F0864335020	A.01.01_0_45556	19	1
F0862448100	D.03.02_0_39758	12	2		D.03.02_0_39758	21	1		A.01.01_1_48842	19	1
	D.03.02_1_39804	11	1		D.03.02_1_39804	18	1		A.01.02_0_48885	19	1
	D.12.01_0_40202	61	1	F0862785000	D.01.02_0_40152	2/1	1		A.01.02_1_45599	19	1
	D.12.01_1_40279	62	1	F0862796000	F.01.03_0_51164	5	4		A.01.03_0_48930	19	1
F0862462010	L.02.02_0_40987	4	1	F0862875000	B.11.01_0_38871	6	1		A.01.03_1_45644	19	1
	L.02.05_0_41145	4	1	F0862944000	D.07.02_0_39660	12	1	F0864357100	W.01.04_0_45316	1.3	5
	M.02.03_0_41409	4	1		D.07.02_1_39700	13	1	F0864377000	B.03.03_0_50588	22	2
	M.02.04_0_41480	4	1	F0863183000	D.07.02_0_39660	38	1	F0864410500	W.01.03_0_44163	2	4
F0862464050	A.05.02_0_45864	24	2		D.07.02_1_39700	40	1		W.01.04_0_45316	2	4
F0862478070	D.10.01_0_39887	8	3	F0863208050	M.01.01_0_41199	46	1	F0865040000	B.08.02_0_38771	1	1

Code	Parts Table	Pos.	Q.ty
F0865040020	B.08.02_0_38771	2	1
F0865474000	B.08.02_0_38771	3	1
F0865474005	B.08.02_0_38771	3.1	1
F0907170150	B.07.02_0_42592	34	1
P000000260007	B.02.01_0_47127	13	1
	B.02.01_1_47161	13	1
P227332000000	F.03.04_0_40779	21	1
	F.03.04_1_40827	21	1
P236220000000	A.03.01_0_45689	28	1
	A.03.02_0_45727	28	1
P236340000000	A.03.01_0_45689	26	1
	A.03.02_0_45727	26	1
P241171000000	L.02.02_0_40987	33	1
	L.02.05_0_41145	34	1
P254124000000	F.04.01_0_46735	30	2
P439149000000	B.03.03_0_50588	21	2
P470330000000	D.12.01_0_40202	14	1
	D.12.01_1_40279	14	1
P470433000000	D.12.01_0_40202	13	1
	D.12.01_1_40279	13	1
P917280000000	B.03.03_0_50588	20	2